

StarTec XT

Technical Instruction Manual



Product features

The StarTec XT wall formwork is a crane-dependent frame formwork system made of hot-dip galvanised and post-treated steel. The multi-purpose formwork StarTec XT is the ideal solution for applications in residential and commercial construction.

With its integrated combination tie hole recessed in the frame, the system can be tied in three ways, both from one side and from two sides, without needing to perform assembly or disassembly measures on the panel. The option of choosing the tying method best suited to the project significantly reduces the formwork placing time. Furthermore, the combination tie hole enables the panels to be stacked without having to remove parts beforehand.

The StarTec XT panel dimensions and the absolutely symmetrical inner tie holes result in a uniform tie hole pattern and a uniform joint pattern for the highest architectural-concrete requirements.

The StarTec XT panels are equipped with the alkus facing made of polypropylene and aluminium. The facing is riveted to the panel on the pouring side. In addition, the facings are protected with silicone. The solid plastic facing has all the positive properties of plywood plus important advantages: longer lifespan, greater load-bearing capacity, better nail-holding ability, fewer and easier repairs, 100% recyclability.

The MEVA multi-function profile with welded-in DW-threaded nuts makes the attachment of accessories easier, for example:

- Push-pull props and alignment rails with flange screws
- Walkway brackets with integrated self-locking pin
- DW tie rods of any length that are used to bridge problem areas.

The maximum permissible fresh-concrete pressure is 60 kN/m^2 . The fresh-concrete pressure according to DIN 18218:2010-01 can be determined easily and precisely with MEVA's online concrete pressure calculator available at www.meva.net.

Safety equipment

SecuritBasic was developed for the StarTec XT; this safety system prevents falling accidents and at the same time increases occupational safety and work efficiency. For more information refer to the SecuritBasic Technical Instruction Manual.

Abbreviations, measurements, figures and tables, etc.

The abbreviation ST XT is used for StarTec XT. DIN means Deutsche Industrie-Norm (German Industrial Standard). E DIN (E = Entwurf / draft) means that the DIN is in draft status and not yet approved. Any further abbreviations are explained where they are used for the first time.

TÜV means Technischer Überwachungsverein. This is the independent German organisation that tests the safety of technical installations, machinery and motor vehicles. If a product passes the test, it is permitted to carry the GS seal. GS stands for Geprüfte Sicherheit (approved safety).

Measurements: This manual uses the metric system, i.e. m (for metre), cm (for centimetre) and mm (for millimetre).

Non-defined dimensions are in cm.

The page numbers in this manual start with ST XT. The figures and tables are numbered per page. Depending on its product abbreviation, a cross reference in the text refers to a page, table or figure in this or in another manual. This is indicated by the product code with which the cross-reference begins.



Contents

Formwork assembly and stripping	4
The StarTec XT panel	8
Overview of panels	11
Tie hole and joint pattern.....	12
alkus all-plastic facing	13
Panel connection	14
Tying methods	15
The combination tie hole	16
Sealing the combination tie hole.....	17
Single-sided tying with XT tie rod DW 20 and plastic tube	18
Single-sided tying with XT taper tie 20.....	20
Single-sided tying with XT taper tie 23.....	22
Single-sided tying with XT taper tie 20 or 23	24
Two-sided tying with DW tie rod and plastic tube	25
Rules for concrete pouring and rate of placing.....	26
Flatness of surface	27
Attachment of accessories	28
Wall braces.....	29
Workplaces.....	31
Workplaces – SecuritBasic safety system	32
Workplaces – Folding access platform BKB 125	33
Working scaffolds – Folding access platform BKB 125.....	34
Workplaces – Walkway bracket	35
Workplaces – Ladder fixture for wall formwork.....	36
Workplaces – Tilting bracket 40/60.....	37
Crane Hook	38
90° corner	39
90° corner – ST inside corner	42
90° corner – AS/ST outside corner	43
90° corner – Height-extended AS/ST outside corner.....	44
Hinged corner.....	45
Stripping corner.....	47
Length compensation	54
Length compensation – Filler widths.....	55
T wall connection	56
T wall connection – Different wall thicknesses	57
Connection to existing walls	58
Wall offset.....	59
Stop ends	60
Pilasters	62
Differences in height.....	63
Horizontal panels.....	64
Height-extending from above or below	65
Stabilisation of units	66
Crane ganging	67
Column formwork – With standard panels.....	69
Closing the tie holes	70
Sealing the tie holes.....	71
Sealing the tie holes – FB active stop XT 20	72
Sealing the tie holes – MEVA multi-stop 23.....	73
Overview of cones and plugs	74
Transport	75
Further applications for StarTec XT.....	78
Services	79
Product list	81

Please note

This Technical Instruction Manual contains information, instructions and tips that describe how to use the MEVA equipment on the construction site in a proper, quick and economic way. Most examples shown are standard applications that will occur in practice most often. For more complicated or special applications not covered in this manual, please contact the MEVA experts for advice. They will help you without delay.

When using our products, the federal, state and local occupational health and safety regulations must be observed. Please observe the assembly instructions that your local contractor or employer has created for the site on which the MEVA equipment is used. Such instructions are intended to minimise site-specific risks and must contain the following details:

- The order in which all working steps including assembly and disassembly must be carried out
- The weight of the panels and other system parts
- The type and number of ties and braces as well as the distance between them
- The location, number and dimensions of working scaffolds including the working area and fall protection equipment required
- Attachment points for panel transport by crane. With regard to panel transport, please observe this manual. Any deviation will require structural verification.

Important: Generally, only well-maintained material may be used. Damaged parts must be replaced. Use only original MEVA spare parts for replacement.

Attention: Never wax or oil assembly locks!

Formwork assembly and stripping

Important!

When assembling and stripping formwork, strictly observe the local accident prevention rules. When using our formwork and systems always observe federal, state and local codes and regulations.

Attention

→ During the entire assembly and stripping process vertical panels must be supported or secured against toppling by other means. This applies to all panel types, hence also to corner panels, curved panels, etc.

→ Above a formwork height of 2.00 m both sides of the formwork must be secured against falling.

Planning

If you want to benefit fully from the efficient and economical use that the formwork offers, we recommend you first plan and prepare its use. Start planning by determining the optimum formwork quantity to be held in stock (the quantity is usually based on the amount of formwork required for a one day's work). When determining the quantity, consider the following:

- The formwork weight
- The time required for formwork assembly and stripping
- Transport of gangs from one pour to the next considerably reduces assembly and stripping effort and time
- Capacity of the lifting devices
- A logical cycle plan that takes corner configurations, reinforcements, etc. into account.

Once all these aspects have been

considered, the quantities of formwork items can be specified.

Ground

The ground on which the formwork is going to be placed should be clean, even and capable of bearing the expected load, as this will help reduce the time required for the assembly and stripping.

Panel transport

When unloading panels or moving panel stacks, make sure to use appropriate transport devices that can bear the load. For detailed information see page ST-XT-75.

The steps required for assembly

For ergonomic reasons the outside formwork is usually assembled and placed first. Start assembly in a corner or at a defined position and perform the following steps:

Step 1 – Place and brace the outside formwork

Step 2 – Define and mark the pouring height, install the reinforcements and boxouts

Step 3 – Place the inside formwork and tie the outside and inside formwork

Refer to the following pages for a detailed description of these steps including the installation of the working platform and formwork stripping.

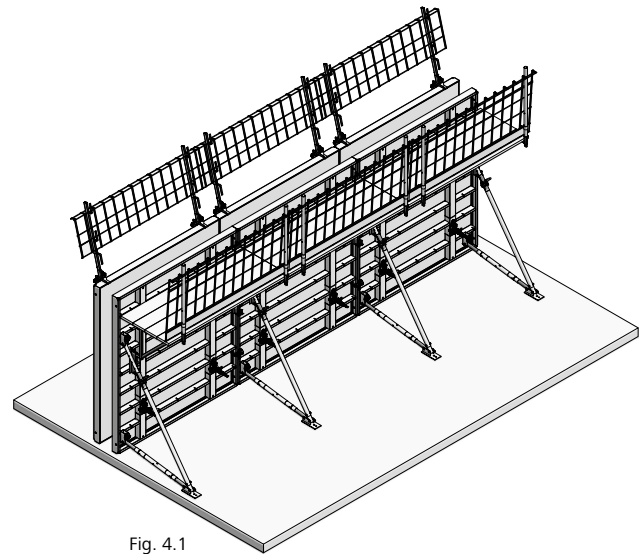

Fig. 4.1

Formwork assembly and stripping

Step 1

Place and brace the outside formwork

The following description is based on a straight wall. Before starting, keep in mind:

→ When pre-assembling large panel units on an even surface, attach the wall braces and the walkway bracket as well, i.e. before performing step 1.

→ Walls of less than 6 m require a filler for easy stripping (Fig. 5.3), as the formwork may otherwise become wedged and stick to the concrete when it is stripped.

1. Spray the facing with the release agent MevaTrenn pro.

2. Place the first panel and immediately attach it to the ground or concrete slab with two brace frames to prevent it falling over (Fig. 5.1). The foot plate must be firmly connected to the ground or concrete slab – in earth with two ground pegs, in concrete with two heavy-duty dowels.

After placing vertical panels, always reinforce them immediately with push-pull props or brace frames so they can withstand tensile and compressive forces and are protected against displacement and wind. The prop spacing is determined by the application. If the walkway bracket was not pre-assembled before step 1, you can now assemble and install the working platform. Fig. 6.2 on page ST-XT-6 shows a working platform being lifted with a crane for attachment to a braced outside formwork.

3. String further panels together and connect them with AS assembly locks (see page ST-XT-14).

Panels with a height of 270 cm are usually connected with two assembly locks. However, outside corner configurations deviate from this rule (Fig. 5.2).

Step 2

Pouring height, reinforcements and boxouts

After performing step 1, the pouring height is defined and marked. Then the reinforcements and boxouts, if required, are installed.

Step 3

Place the inside formwork and tie the outside and inside formwork

The inside formwork is placed after the outside formwork. The inside and outside formwork are then tied firmly with tie rods (for the tying methods refer to page ST-XT-15).

Note

Correct set-up of the formwork to the desired wall thickness is facilitated by using a stop or a mark on the ground which allows the inside formwork to be positioned exactly.

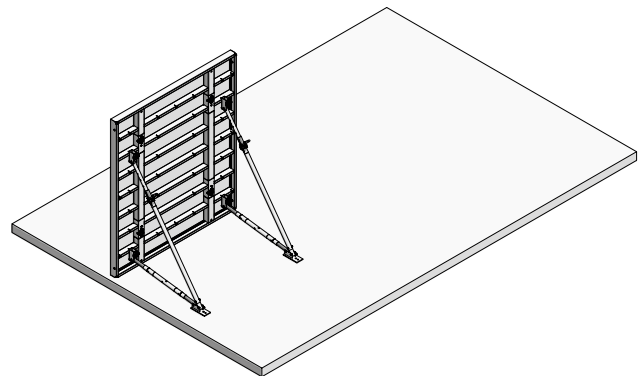

Fig. 5.1

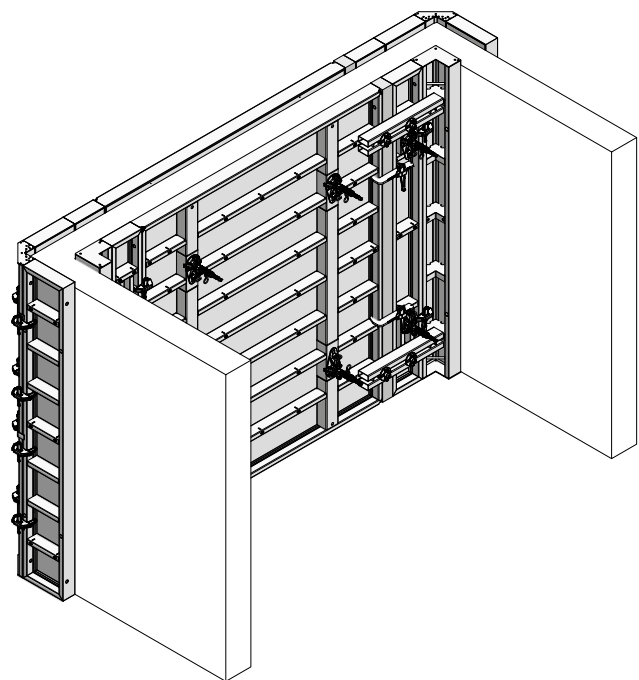

Fig. 5.2

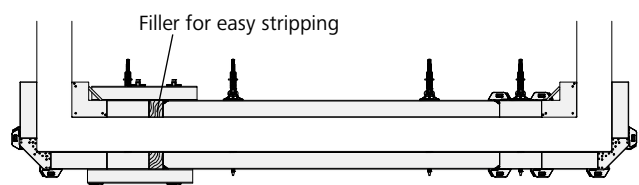

Fig. 5.3

Formwork assembly and stripping

Working scaffold

The plug-in walkway bracket is used to support the working scaffold. The maximum bracket spacing for a load of 150 kg/m² (platform group 2) is 2.50 m as defined in DIN 4420. The planking must be at least 4.5 cm thick.

The planking and walkway bracket can be firmly connected. Do not install any planks before securing the formwork with push-pull props or before tying the inside and the outside formwork.

Do not forget to attach a side railing to the working scaffold.

MEVA's SecuritBasic safety system offers platforms, ladder access and other safety equipment for safe and efficient work at all heights (see page ST-XT-32).

Figures 6.1 and 6.2 show the folding access platform BKB 125 being used as a working scaffold.

Pouring concrete

Once you have placed, tied, braced and closed the formwork, you can start pouring concrete. When doing so, observe the permissible rate of placing taking the setting behaviour and the consistency of the cement into account (see page ST-XT-26).

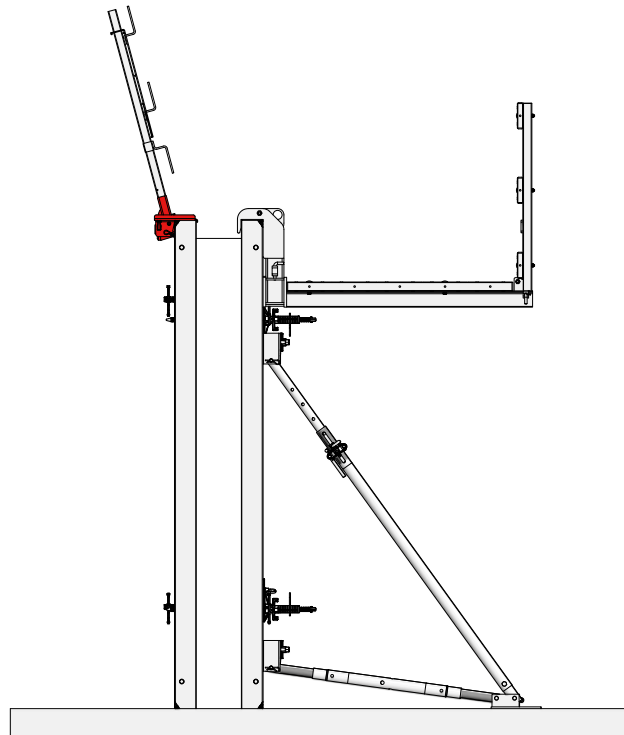

Fig. 6.1

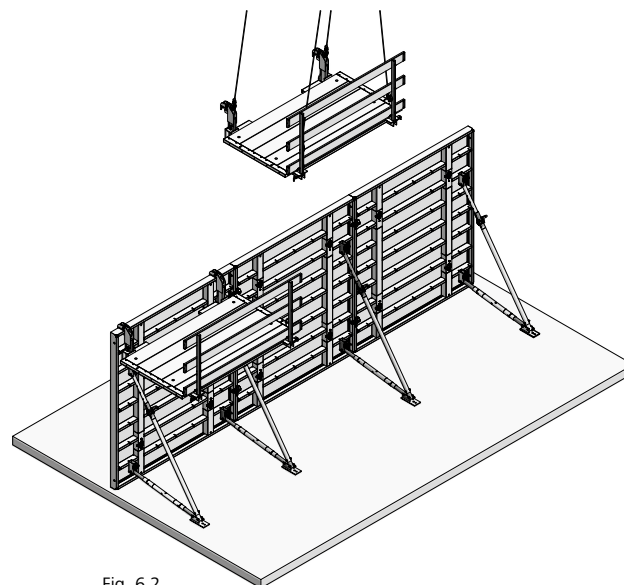

Fig. 6.2

Formwork assembly and stripping

Stripping

Do not start stripping before the concrete has set to the point where it can no longer deform. It is best to start stripping at the stop ends or at a short corner. Start stripping with the inside formwork. Stripping of both the outside and inside formwork is performed as follows:

1. Remove the tie rods section by section (for the tying methods refer to page ST-XT-15). Make sure the unbraced formwork is immediately secured to prevent it falling over or strip it immediately.
2. On the formwork panels and large panel units the assembly locks are removed at the joints, and the panels or panel units are then lifted out by hand or by crane. Before removing them with a crane, make sure the formwork is detached from the concrete!
3. Clean the facing and remove any concrete. Before the next use, spray the facing with the release agent MevaTrenn pro (for alkus facings). Observe the operating instructions for the alkus facing.

Note

The release agent must not be stored in galvanized containers.

Please note

When stripping manually, detach and disassemble the working scaffold and the brace frames before stripping the panels.

When transporting large panel units with a crane, the working scaffold and wall braces are moved together with the panel units. While vertical, all components are cleaned and sprayed with release agent before being lifted together to the next cycle (see also pages ST-XT-67 and ST-XT-68).

If there is no further use for the panel units, the working scaffold and wall braces are detached and disassembled in a horizontal position, and cleaned and stacked for transport.

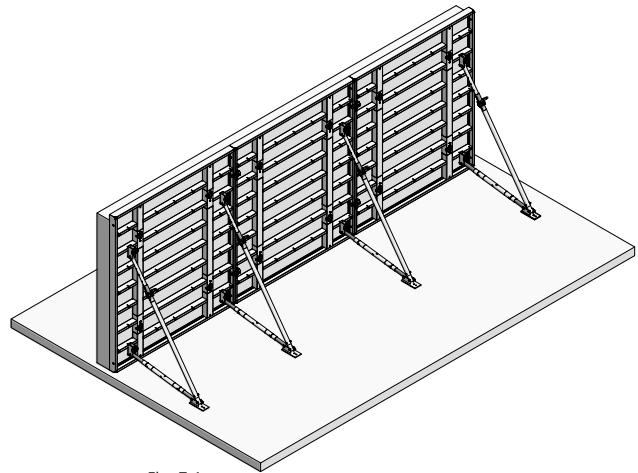

Fig. 7.1

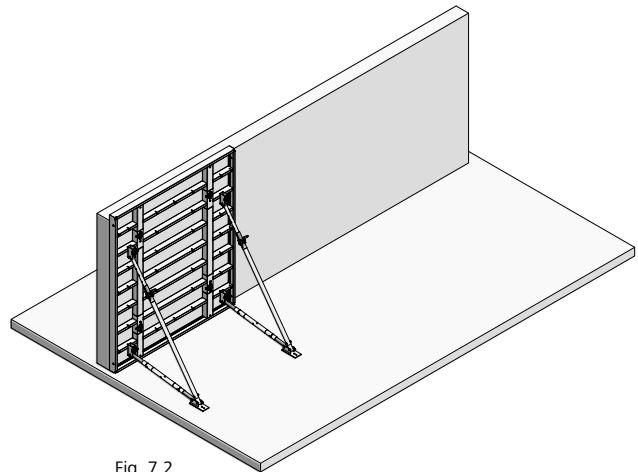

Fig. 7.2

Wall Formwork

The StarTec XT panel

The StarTec XT panel with internal combination tie holes (Fig. 8.1).

- Combination tie hole with rotating sphere for single- and two-sided tying (Fig. 8.2).
- Panel connection with the AS assembly lock in the continuous groove (Fig. 8.3).
- Cross stiffener made of sturdy closed steel profile with welded-in DW 15 threaded nuts for fast and solid attachment of accessories (Fig. 8.4).
- Transport hole to attach the lifting hook 40, allowing for fast loading and unloading of panel stacks or their relocation at ground or slab level (Fig. 8.5).
- The steel frames are made of closed hollow profiles with welded-in mitred joints. The profiles are provided with a simple groove and edge protection.

Note

For a list of the available panels including their designations and reference numbers refer to the Product List.

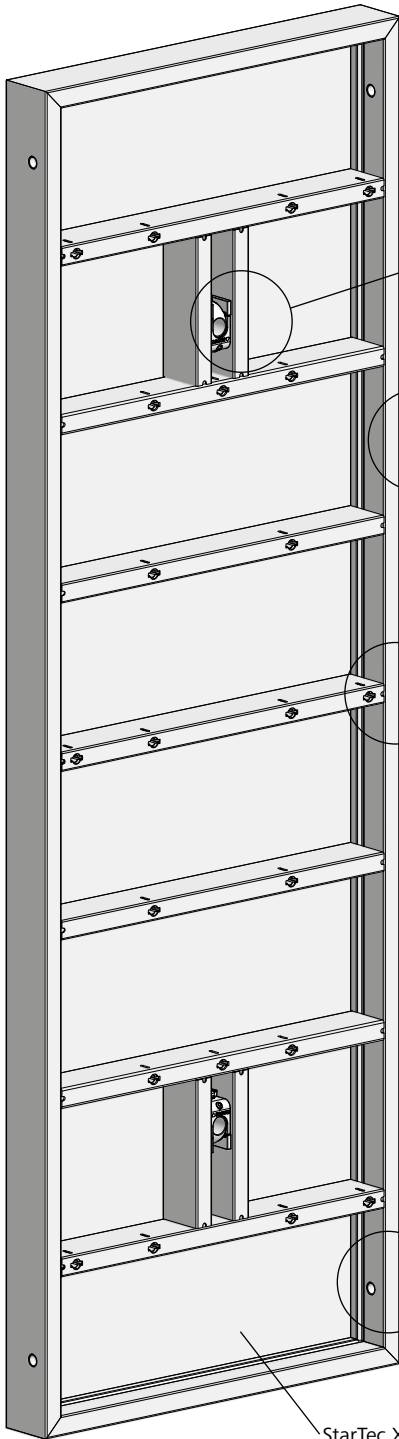

Fig. 8.1

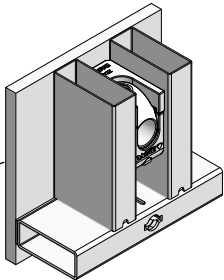

Fig. 8.2

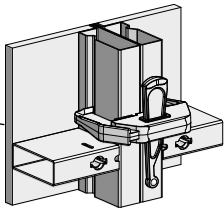

Fig. 8.3

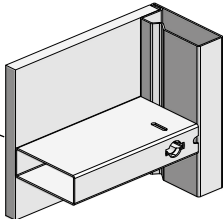

Fig. 8.4

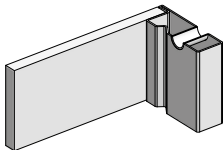

Fig. 8.5

Description	Ref. No.
StarTec XT AL 270/90	21-202-11

The StarTec XT panel

Like all other StarTec XT panels, the large StarTec XT 330/270 panel (Fig. 9.1) also has internal tie holes. Thus, for the forming area of 8.91 m² only six ties are required.

→ Large panels are equipped with a bump notch at each of the four corners (Fig. 9.2) that are welded in diagonally, allowing exact panel positioning without a hammer.

→ The tie rod holder Ø35 can be attached to the multi-function profile of the vertical (Fig. 9.1) or horizontal StarTec XT panel. To install it, the tie rod holder is turned by 45° (Fig. 9.3), inserted into the multi-function nut and then turned back again. It can hold up to two XT DW tie rods, XT taper ties or DW tie rods with articulated flange nut (Fig. 9.3).

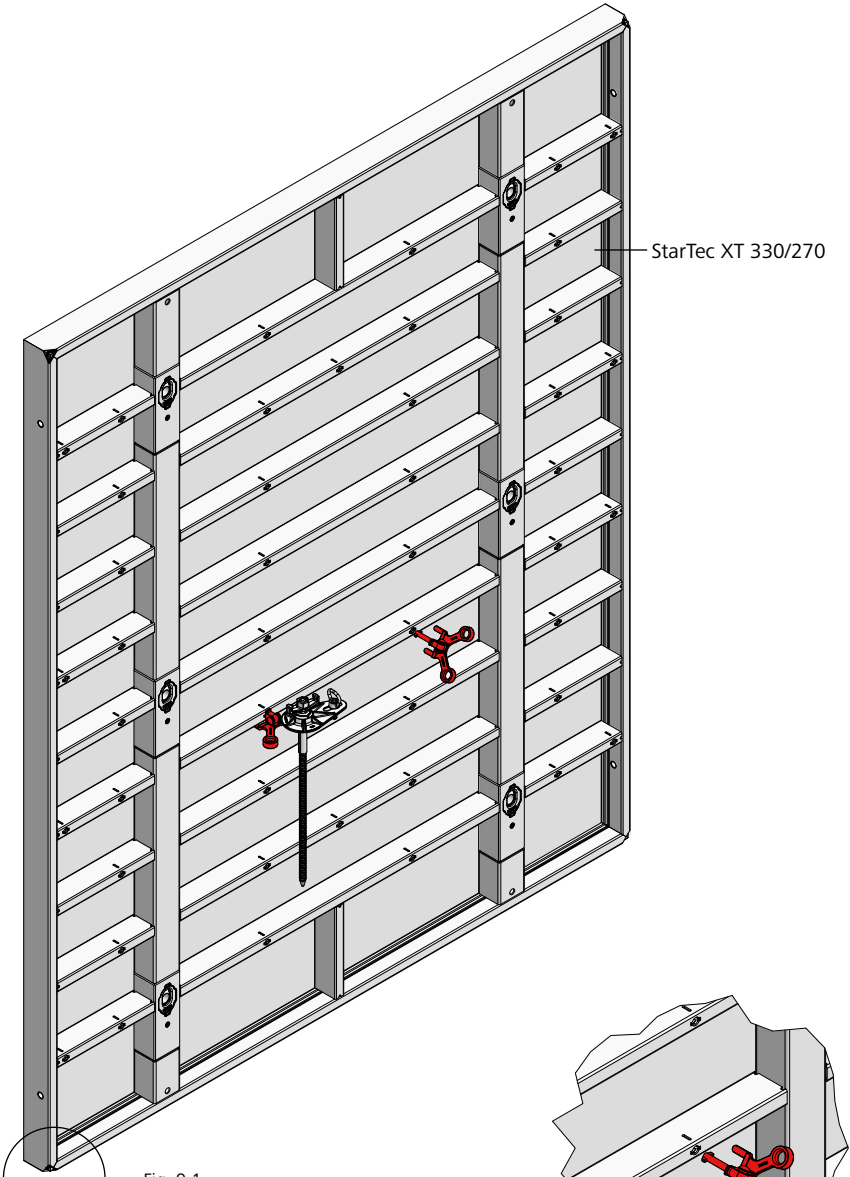

Fig. 9.1

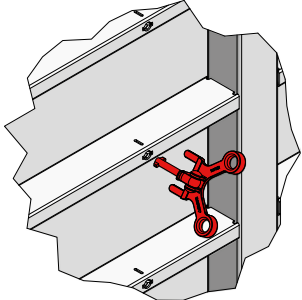

Fig. 9.3

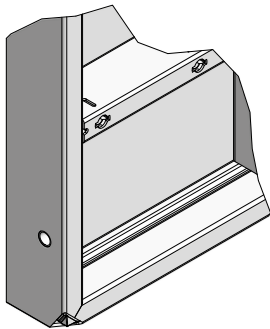

Fig. 9.2

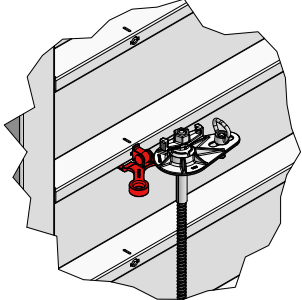

Fig. 9.4

Description	Ref. No.
StarTec XT AL 330/270	21-201-01
Tie rod holder Ø35	29-927-05

The StarTec XT panel

When height-extending from above or below, the StarTec XT panels

- 135/330 (Fig. 10.1) and
- 135/240 (Fig. 10.2) are particularly suitable.

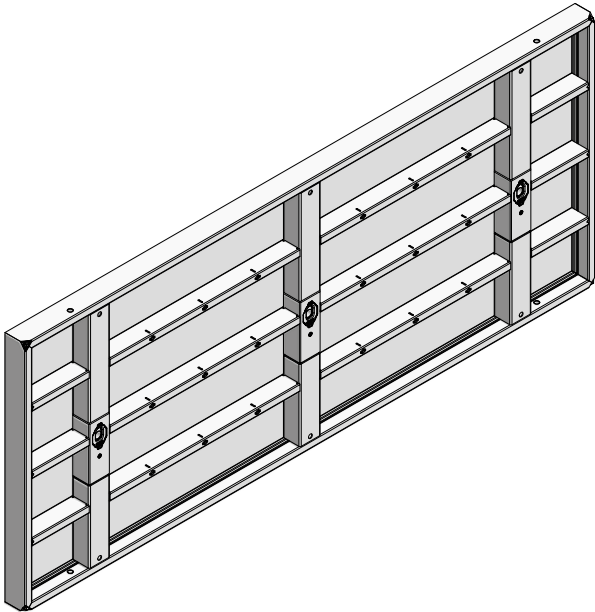

Fig. 10.1

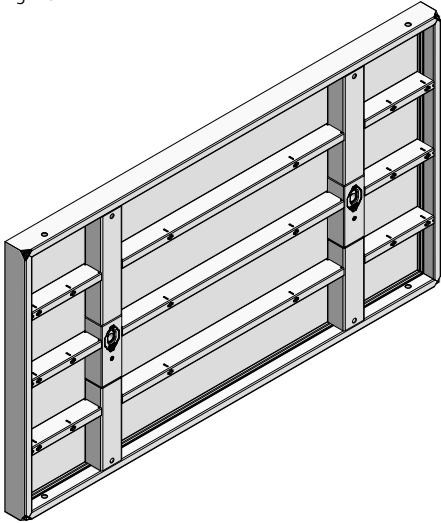

Fig. 10.2

Description	Ref. No.
StarTec XT AL 135/330.	21-203-01
StarTec XT AL 135/240.	21-203-03

Tie hole and joint pattern

The StarTec XT panel dimensions and the symmetrical internal tie holes result in a uniform tie hole and joint pattern for the highest architectural-concrete requirements. This applies to vertical, horizontal or a combination of vertical and horizontal formwork (Figures 12.1 and 12.2).

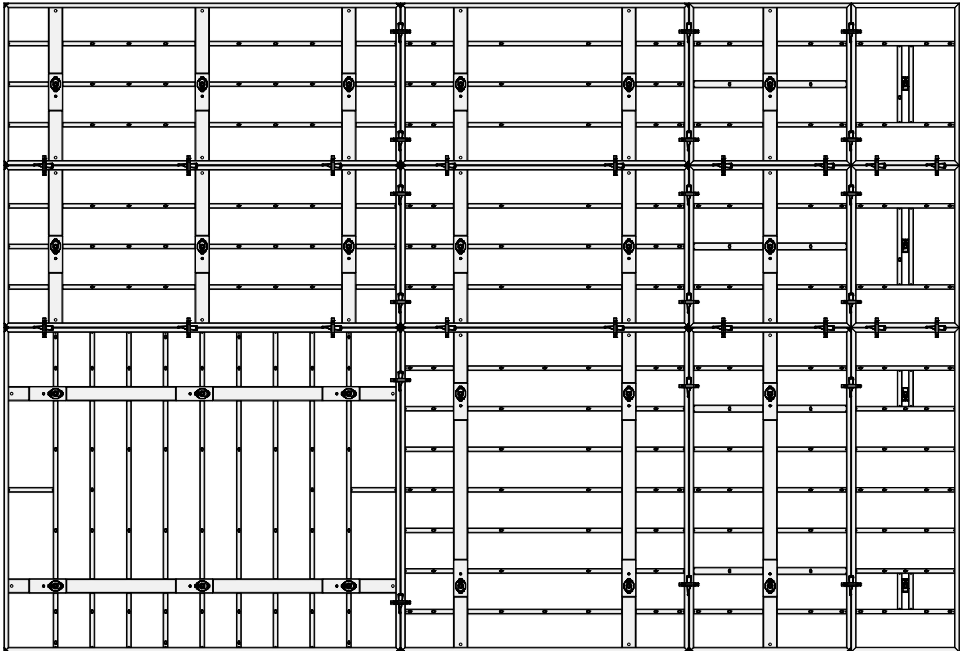

Fig. 12.1

Tie hole and joint pattern

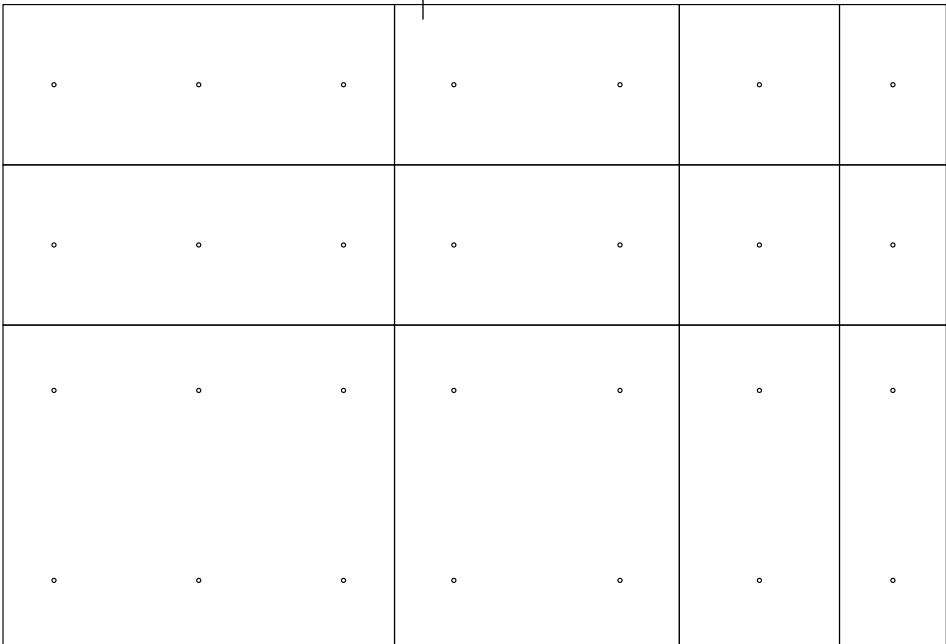

Fig. 12.2

alkus all-plastic facing

The tried-and-tested polypropylene and aluminium composite facing (Fig. 13.3) has all the positive properties of plywood plus important advantages: longer lifespan, greater load-bearing capacity, better nail-holding ability, fewer and easier repairs, 100% recyclability.

Besides the obvious advantages such as considerably reduced cleaning effort, minimum consumption of release agent and an excellent, uniform concrete finish, alkus offers substantial ecological benefits.

Substituting plastic for wood saves valuable timber resources. Also, alkus avoids the release of highly toxic dioxin that is released when burning plywood bonded with phenolic resin.

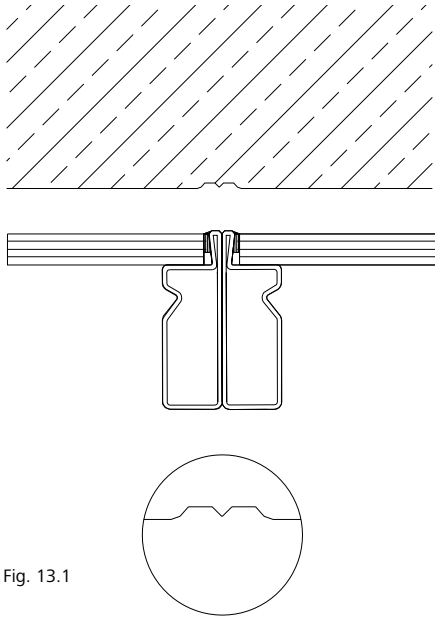

Fig. 13.1

Frame profile with plywood facing:
Negative imprint in the concrete when using panels with a conventional plywood facing

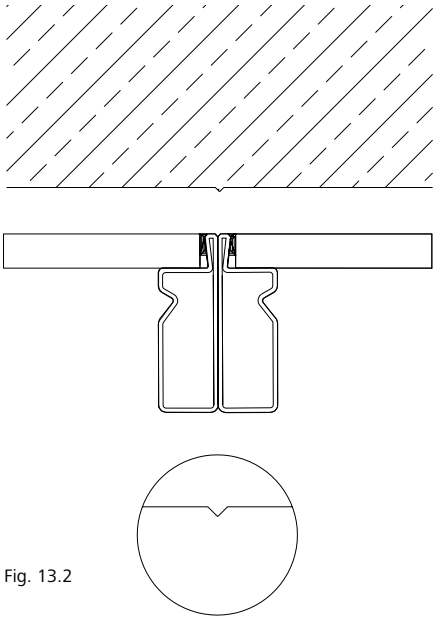

Fig. 13.2

Frame profile with alkus facing:
Smooth and even concrete surface as there are no projecting profiles

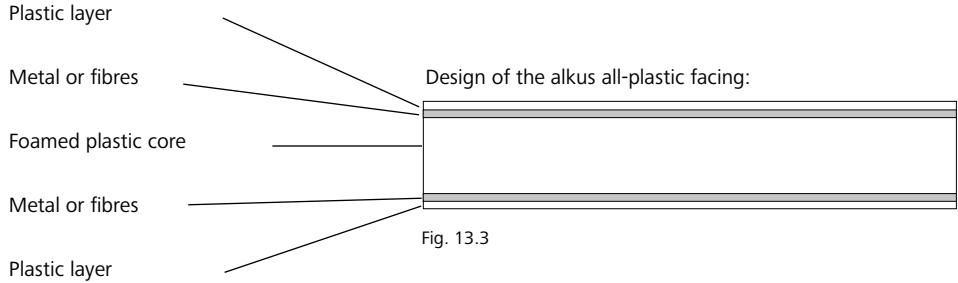

Fig. 13.3

Wall Formwork

Panel connection

Fast and efficient connection of the panels is accomplished with the AS assembly lock (Fig. 14.1) whether the panels are assembled side by side or on top of each other (height-extended). The assembly lock can be attached at any position on the panel joint between the cross stiffeners. Since it weighs only 2 kg, it can be easily attached with only one hand.

Its five-point contact (Fig. 14.3) draws the panels together and aligns them. Secure connection and perfect alignment are achieved with only a few hammer blows. The assembly lock locks into a fail-safe position immediately and automatically.

Panels are generally connected as follows:

- up to a height of 270 cm with two assembly locks and
- up to a height of 330 cm with three assembly locks.
- When pouring walls in SB3 quality (German architectural concrete class for immaculate architectural concrete surfaces), the use of an additional assembly lock is recommended to connect panels that are 270 cm high or higher.
- Horizontal panel connections generally require two assembly locks.

For the quantity of assembly locks required for outside corners and columns refer to pages ST-XT-43 and -44 as well as ST-XT-69.

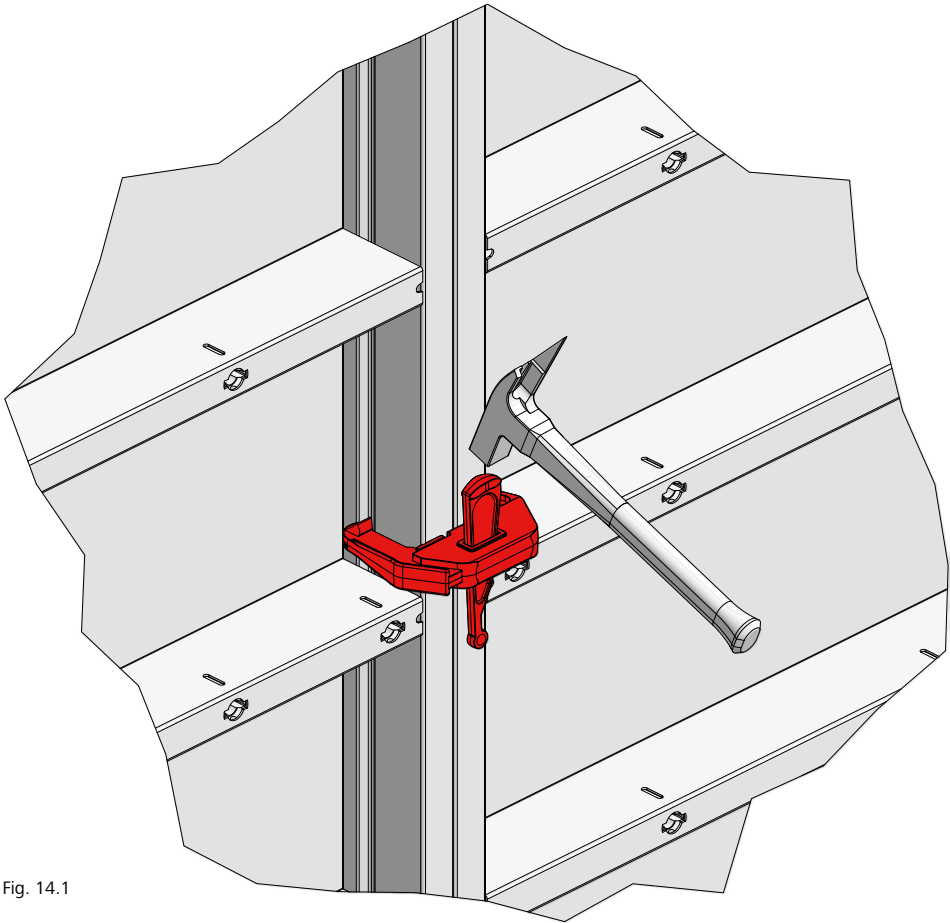

Fig. 14.1

○ = 5-point contact

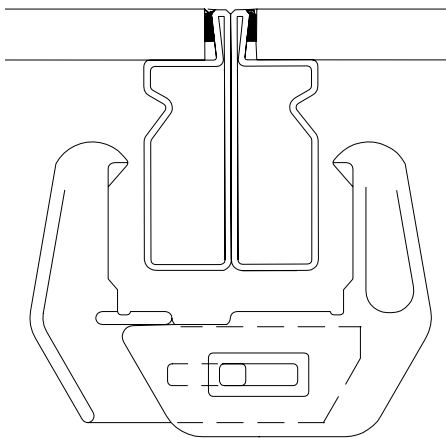

Fig. 14.2

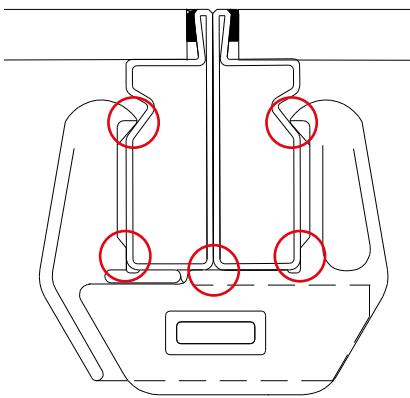

Fig. 14.3

Description	Ref. No.
AS assembly lock	29-205-00

Tying methods

The StarTec XT allows three different tying methods:

- Single-sided tying with XT tie rod DW 20 and plastic tube (Fig. 15.1)
- Single-sided tying with XT taper tie 20 or 23 without plastic tube (Fig. 15.2)
- Two-sided tying with DW tie rod and plastic tube (Fig. 15.3)

Attention

Unused tie holes must always be closed with plug D35/38 or alternatively with XT sealing cone with a pressed-on plug D20 (see page ST-XT-17).

Single-sided tying with XT tie rod DW 20 and plastic tube

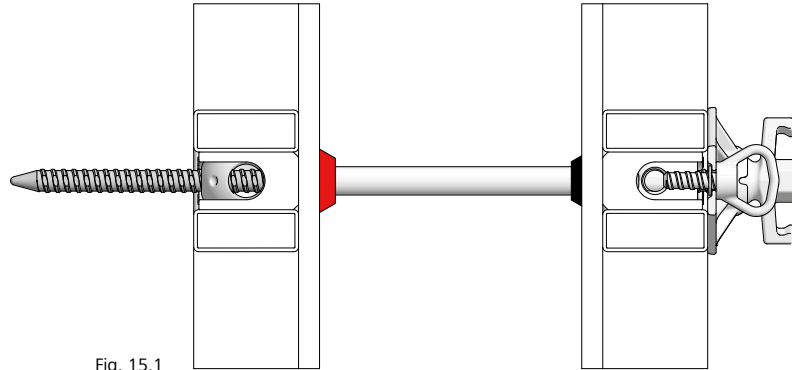

Fig. 15.1

Single-sided tying with XT taper tie 20 or 23 without plastic tube

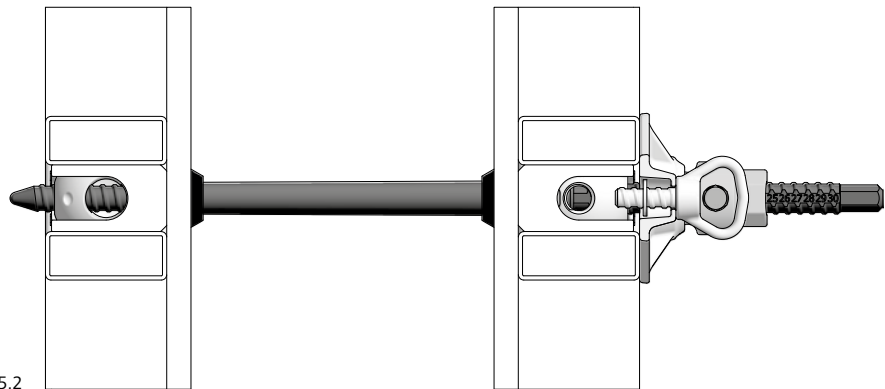

Fig. 15.2

Two-sided tying DW and plastic tube

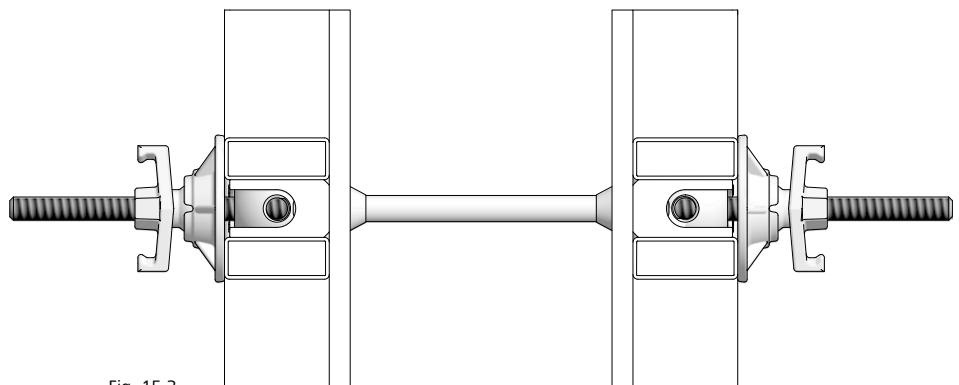

Fig. 15.3

Description	Ref. No.
XT tie rod DW 20/75.....	23-154-35
XT tie rod DW 20/120.....	23-154-40
Plastic tube D23/200.....	29-902-31
Plastic tube D23/18.....	29-902-03
Plastic tube D23/23.....	29-902-04
Plastic tube D23/28.....	29-902-05
Plastic tube D23/33.....	29-902-06
XT taper tie 20/15-25	23-154-10
XT taper tie 20/20-30	23-154-15
XT taper tie 20/35-45	23-154-20
XT taper tie 23/15-25	23-154-60
XT taper tie 23/20-30	23-154-65
XT taper tie 23/35-45	23-154-70
XT taper tie 23/45-55	23-154-75
XT taper tie 23/60-70	23-154-80
XT sealing cone 5 AL20	29-902-34
XT sealing cone 10 AL20	29-902-35
XT sealing cone 5 AL17	29-902-33
XT sealing cone 10 AL17	29-902-42
XT cone DW	29-902-37
Tie rod DW 20/120	29-900-97
Articulated flange nut 20/140	29-900-05
Plug D35/38	29-902-71
Plug D20, red.....	29-902-63

The combination tie hole

The combination tie hole (Fig. 16.1) is a rotating attachment point for DW tie rods and XT taper ties.

It is recessed and firmly integrated in the panel (Fig. 16.1).

Depending on the tying method selected (Table 16.6 and page ST-XT-15), the sphere of the combination tie hole can be rotated by 90° to set it to either a conical anchor sleeve (Fig. 16.4) or a DW 20 thread (Fig. 16.5).

Setting it to the DW thread (Fig. 16.5 and Table 16.6) replaces the articulated flange nut on the formwork wall that is installed first (initial formwork) and allows single-sided tying.

The anchor sleeve (Fig. 16.4 and Table 16.6) is preset on the initial-formwork side for two-sided tying.

The combination tie hole is set using the XT combi lever (Figures 16.2 and 16.3).

Attention

- As far as possible, tie rods are to be placed in every combination tie hole.
- The karabiner hook on the XT combi lever is for storage purposes only and is not suitable for climbing.

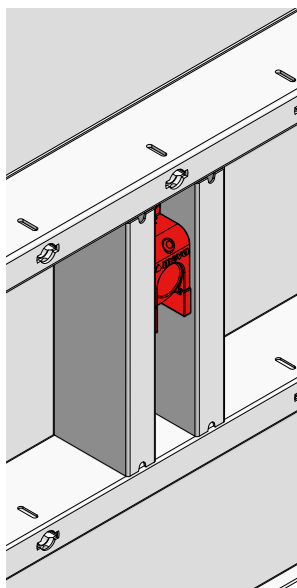

Fig. 16.1

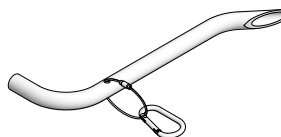

Fig. 16.2

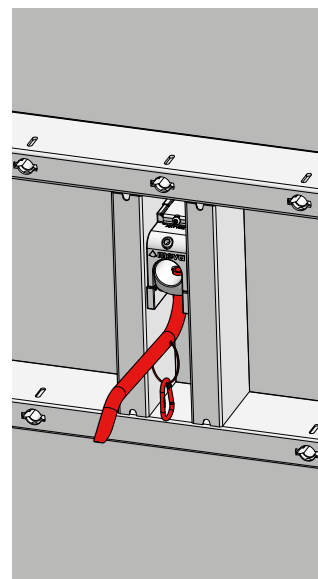

Fig. 16.3

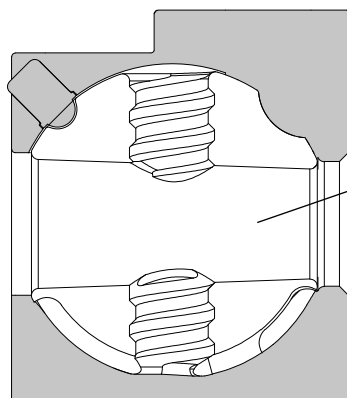

Fig. 16.4

Anchor sleeve

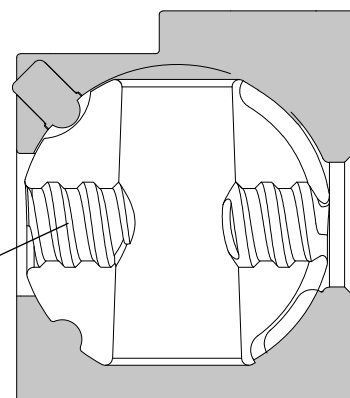

Fig. 16.5

Thread

Tying method	Initial formwork	Final formwork
Single-sided with XT tie rod DW 20 and plastic tube	Thread	Anchor sleeve
Single-sided with XT taper tie 20 or 23 without plastic tube	Thread	Anchor sleeve
Two-sided with DW tie rod and plastic tube	Anchor sleeve	Anchor sleeve

Table 16.6

Description	Ref. No.
XT combi lever.....	23-154-90

Sealing the combination tie hole

Various cones are available to seal the combination tie hole on the facing side.

The XT sealing cone 5 AL is used for single-sided tying (Fig. 17.1).

All StarTec XT panels are delivered with pre-installed XT sealing cone 5 AL.

The XT sealing cones 5 AL and 10 AL are available in the sizes 20 and 17. The size to be used depends on the thickness of the alkus facing in the StarTec XT panel (Table 17.6).

If a clearly visible shadow gap is required, the XT sealing cones 10 AL20 and AL17 (Fig. 17.2) are used for single-sided tying.

If tying is performed from two sides with DW tie rod and plastic tube, the cone for plastic tube D32 (Fig. 17.3) is to be used.

The same cone is used on the initial- and the final-formwork sides.

To close unused combination tie holes, e.g. in the corner area, the plug D35/38 or alternatively any XT sealing cone with pressed-on plug D20 can be used (Fig. 17.5).

The XT sealing cone can be easily removed from the StarTec XT formwork panel without causing damage using the XT combi lever.

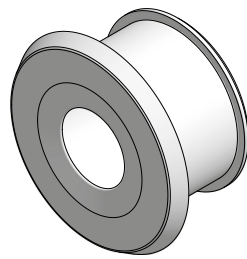

Fig. 17.1

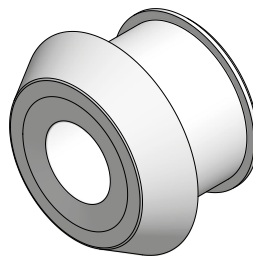

Fig. 17.2

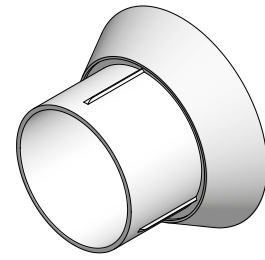

Fig. 17.3

Tying method	XT sealing cone 5 AL20/AL17	XT sealing cone 10 AL20/AL17	Cone for plastic tube D32
Single-sided with XT tie rod DW 20 and plastic tube	Yes	Yes	No
Single-sided with XT taper tie 20 or 23 without plastic tube	Yes	Yes	No
Two-sided with DW tie rod and plastic tube	No	No	Yes

Table 17.4

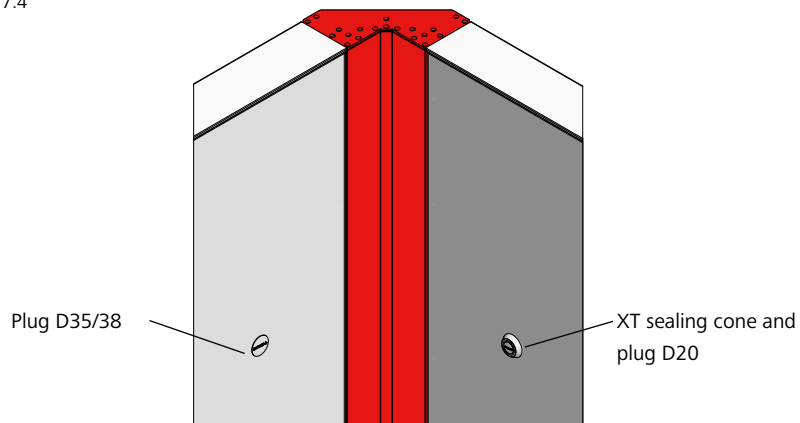

Fig. 17.5

XT sealing cone 5 AL or 10 AL in StarTec XT panel		Panel height		
		330	270	135
Panel width	270	AL 20	X	X
	240	X	AL 20	AL 20
	135	AL 20	AL 20	AL 20
	90	X	AL 17	AL 17
	60	X	AL 17	AL 17
	49	X	AL 17	AL 17
	45	X	AL 17	AL 17
30	X	AL 17	AL 17	

Table 17.6

Description	Ref. No.
XT sealing cone 5 AL20	29-902-34
XT sealing cone 5 AL17	29-902-33
XT sealing cone 10 AL20	29-902-35
XT sealing cone 10 AL17	29-902-42
Cone for plastic tube D32/10.	29-902-55
Plug D35/38	29-902-71
Plug D20, red.....	29-902-63

Wall Formwork

Single-sided tying with XT tie rod DW 20 and plastic tube

When tying StarTec XT formwork on one side only using DW 20 tie rods (Fig. 18.1) and plastic tubes, the combination tie holes in the initial-formwork panels are set to the threaded position and all other panels are set to the anchor sleeve position (Fig. 18.2 and Table ST-XT-16.6).

Seal all tie holes with the XT sealing cone (Fig. 18.2 and page ST-XT-17).

To correctly position the plastic tube, press the XT cone DW 20 on to the XT sealing cone on the initial-formwork side.

The wall thickness is determined by the length of the plastic tube. The plastic tube must be 20 mm shorter than the desired wall thickness (Fig. 18.2).

Plastic tubes D23 are available in the corresponding lengths for wall thicknesses 20, 25, 30 and 35 cm (Table 18.3).

Only the plastic tube D23/200 can be used.

XT tie rod:

- ➔ DW 20/75 for wall thickness up to 40 cm
- ➔ DW 20/120 for wall thickness up to 85 cm

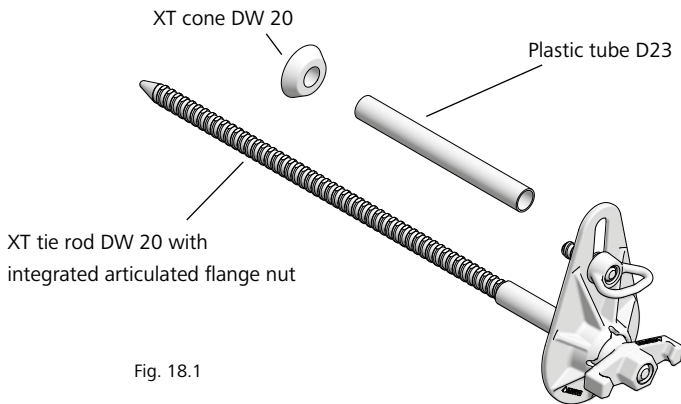

Fig. 18.1

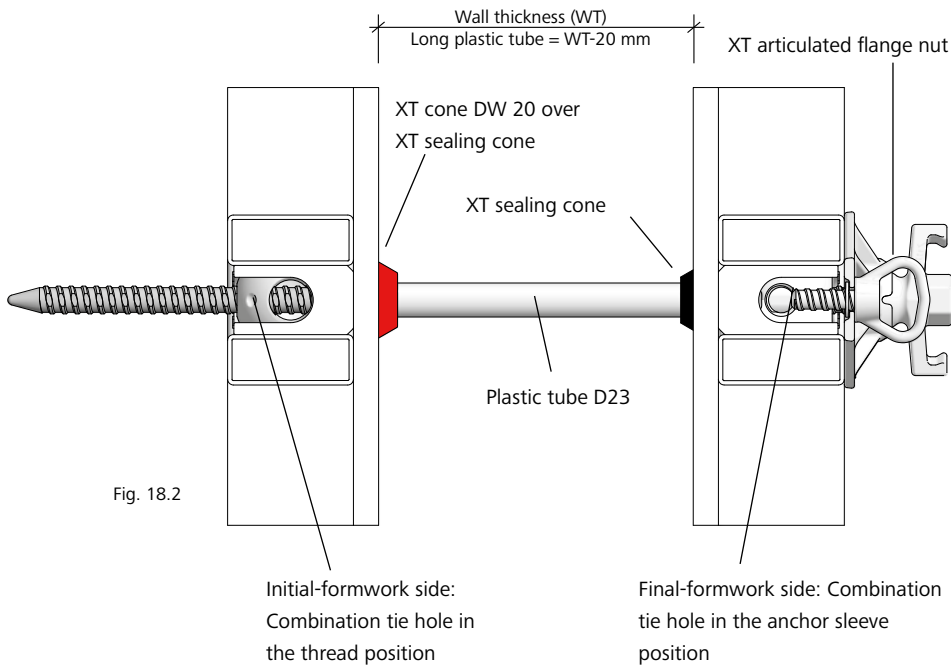

Fig. 18.2

Pre-cut plastic tube	Wall thickness (cm)
D23/18	20
D23/23	25
D23/28	30
D23/33	35

Table 18.3

Description	Ref. No.
XT tie rod DW 20/75.....	23-154-35
XT tie rod DW 20/120.....	23-154-40
Plastic tube D23/200.....	29-902-31
Plastic tube D23/18.....	29-902-03
Plastic tube D23/23.....	29-902-04
Plastic tube D23/28.....	29-902-05
Plastic tube D23/33.....	29-902-06
XT sealing cone 5 AL20	29-902-34
XT sealing cone 5 AL17	29-902-33
XT sealing cone 10 AL20	29-902-35
XT sealing cone 10 AL17	29-902-42
XT cone DW 20	29-902-37

Single-sided tying with XT tie rod DW 20 and plastic tube

Assembly

Before pouring:

1. Press XT cone DW 20 onto the XT sealing cone on the initial-formwork panel (Fig. 19.1, steps 1. to 3.).
2. Place initial-formwork panel (Fig. 19.1 and ST-XT-5), and carry out boxout work (Fig. 19.2).
3. Place final-formwork panel (Fig. 19.3).
4. Install plastic tube D23 on the XT tie rod DW 20. The length of the plastic tube depends on the wall thickness (see page ST-XT-18).
5. Screw the XT tie rod DW 20 through the combination tie hole of the final-formwork side into the combination tie hole of the initial-formwork panel 36 mm ratchet spanner (Fig. 19.4). An articulated flange nut is not required on the initial-formwork side.

6. Secure the XT tie rod DW 20 tightly by hand to the multi-function nut of the formwork panel using the fixation screw integrated into the XT articulated flange nut.

Disassembly

After pouring:

7. To strip the formwork, undo the fixation screw on the XT tie rod DW 20 and screw the tie rod out of the combination tie hole of the initial-formwork panel using the 36 mm ratchet spanner.

Notes

- Correct set-up of the formwork to the desired wall thickness is facilitated by using a stop or a mark on the ground which allows the inside formwork to be positioned exactly.
- The XT tie rod DW can be screwed in or out using a ratchet spanner. The width across flats is 36.
- When stripping, ensure that the StarTec XT panel has been completely separated from the concrete before lifting it with the crane.

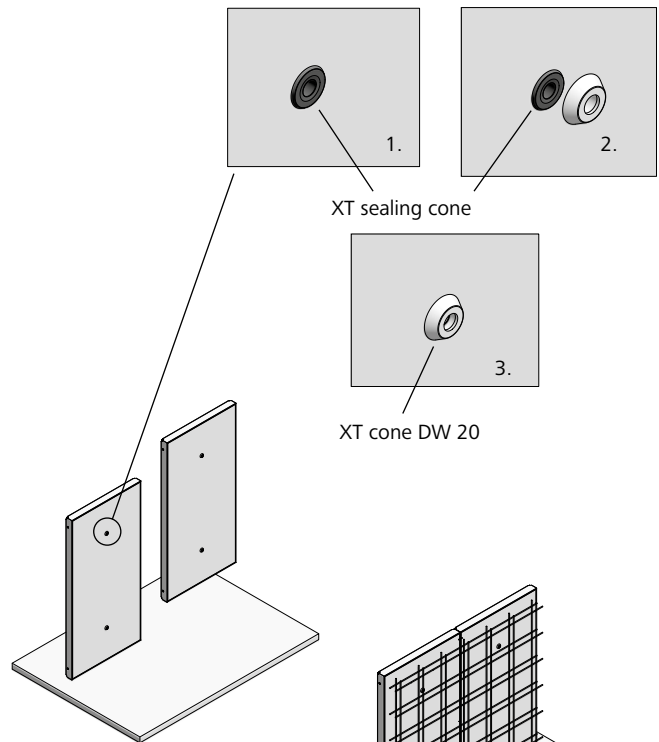

Fig. 19.1

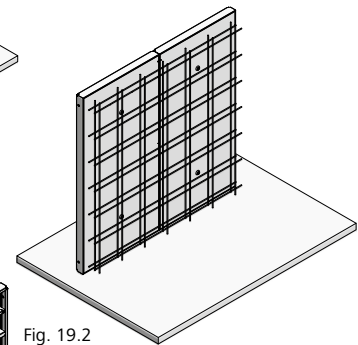

Fig. 19.2

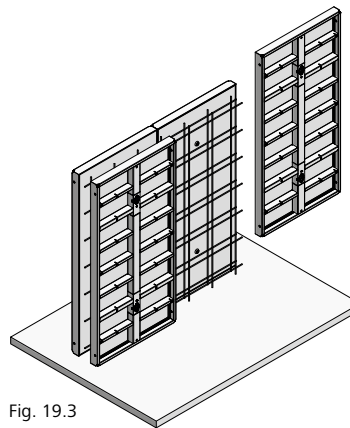

Fig. 19.3

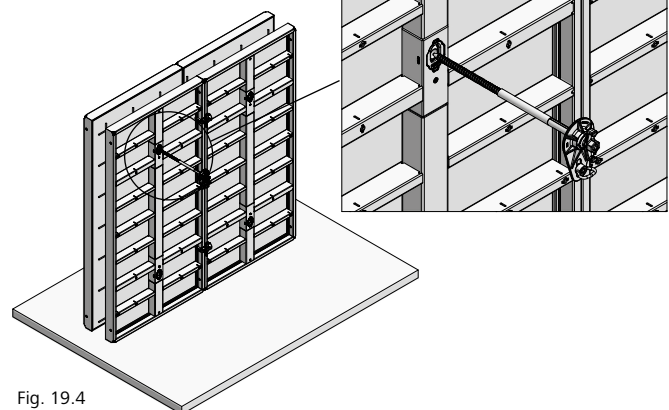

Fig. 19.4

Description	Ref. No.
XT tie rod DW 20/75.....	23-154-35
XT tie rod DW 20/120.....	23-154-40
Plastic tube D23/200.....	29-902-31
Plastic tube D23/18.....	29-902-03
Plastic tube D23/23.....	29-902-04
Plastic tube D23/28.....	29-902-05
Plastic tube D23/33.....	29-902-06
XT sealing cone 5 AL20	29-902-34
XT sealing cone 5 AL17	29-902-33
XT sealing cone 10 AL20	29-902-35
XT sealing cone 10 AL17	29-902-42
XT cone DW 20	29-902-37
Spanner size 36	29-800-15

Wall Formwork

Single-sided tying with XT taper tie 20

When tying StarTec XT formwork on one side only using XT taper ties 20, the combination tie holes in the panels of the initial-formwork panel are set to the threaded position and all other panels are set to the anchor sleeve position (Fig 20.2 and page ST-XT-16).

The XT taper tie 20 is available in various lengths for different wall thicknesses.

XT taper tie 20:

- 15–25 cm
- 20–30 cm
- 35–45 cm

It can be set for different wall thicknesses in 1 cm increments using spacers. The desired wall thickness can be read off the spacers (see page ST-XT-21).

The XT taper tie 20 can be screwed in or out using the XT taper tie ratchet spanner. The width across flats is 17.

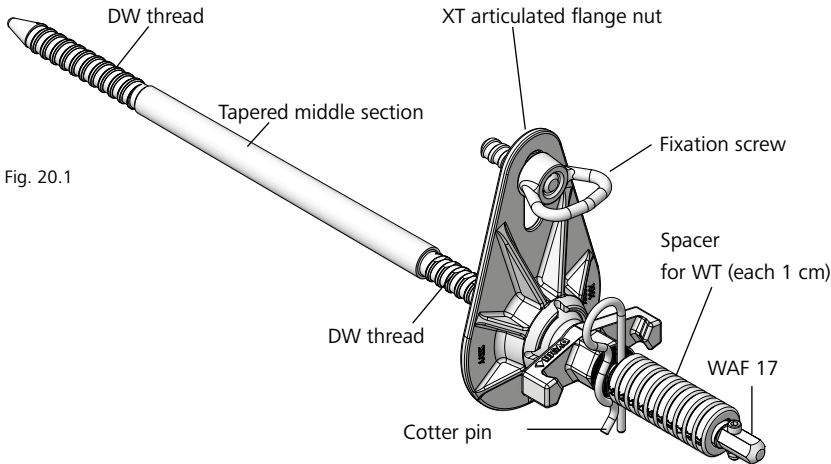

Fig. 20.1

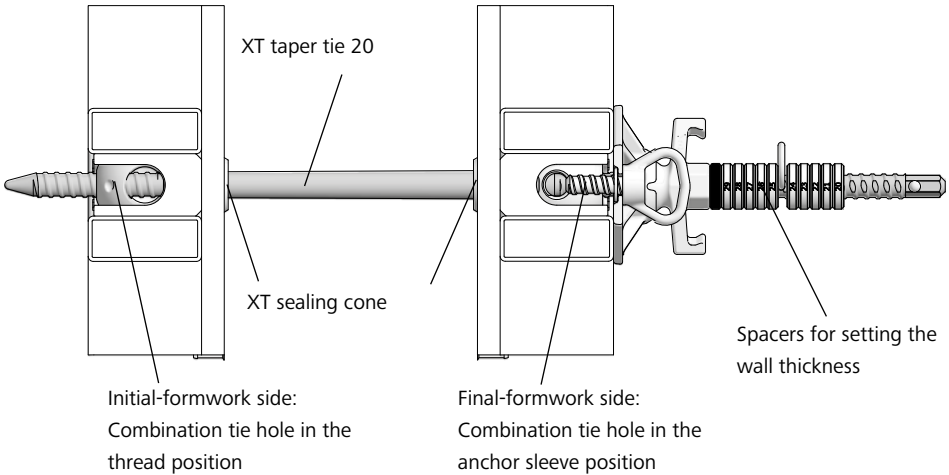

Fig. 20.2

Description	Ref. No.
XT sealing cone 5 AL20	29-902-34
XT sealing cone 5 AL17	29-902-33
XT sealing cone 10 AL20	29-902-35
XT sealing cone 10 AL17	29-902-42
XT taper tie 20/15-25	23-154-10
XT taper tie 20/20-30	23-154-15
XT taper tie 20/35-45	23-154-20
Divinol wax.....	29-203-30

Wall Formwork

Single-sided tying with XT taper tie 20

To set the wall thickness, remove the cotter pin from the XT taper tie 20 and install the required number of spacers in front of the cotter pin hole (Table 21.3). Each spacer is 1 cm thick. The desired wall thickness can be read off the spacer next to the cotter pin.

- Examples:
- Desired wall thickness = 35 cm:
XT taper tie 20/35-45, all spacers for WT in front of the cotter pin. (Fig. 21.1 and Table 21.3)
 - Desired wall thickness = 25 cm:
XT taper tie 20/20-30, spacer no. 25 in front of the cotter pin (Fig. 21.2 and Table 21.3)

Note
A coating of Divinol wax must be applied to the XT taper tie before and after each use.

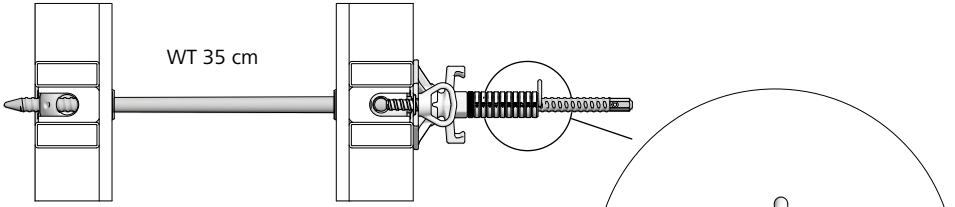

Fig. 21.1

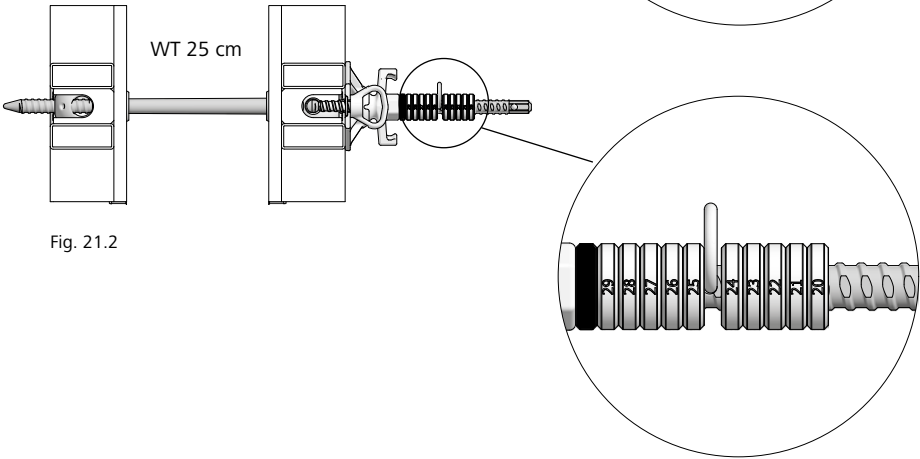

Fig. 21.2

Wall thickness (WT) in cm	XT taper tie 20	Spacers in front of the hole
15	15-25	11
20	(15-25) 20-30	(6) 11
24	(15-25) 20-30	(2) 7
25	(15-25) 20-30	(1) 6
30	20-30	1
35	35-45	11
40	35-45	6
45	35-45	1

Table 21.3

Description	Ref. No.
XT taper tie 20/15-25	23-154-10
XT taper tie 20/20-30	23-154-15
XT taper tie 20/35-45	23-154-20
Divinol wax.....	29-203-30

Single-sided tying with XT taper tie 23

The XT taper tie 23 (Fig. 22.1) is available in various lengths for different wall thicknesses.

XT taper tie 23:

- 15–25 cm
- 20–30 cm
- 35–45 cm
- 45–55 cm
- 60–70 cm

It can be set for different wall thicknesses in 0.5 cm increments using the adjustment screw on the XT articulated flange nut.

When tying StarTec XT formwork on one side only using XT taper ties 23, the combination tie holes in the panels of the initial-formwork panel are set to the threaded position and all other panels are set to the anchor sleeve position (see page ST-XT-16).

The XT taper tie 23 can be screwed in or out and the adjustment screw for the wall thickness can be undone and tightened using the XT taper tie ratchet spanner. The width across flats is 19.

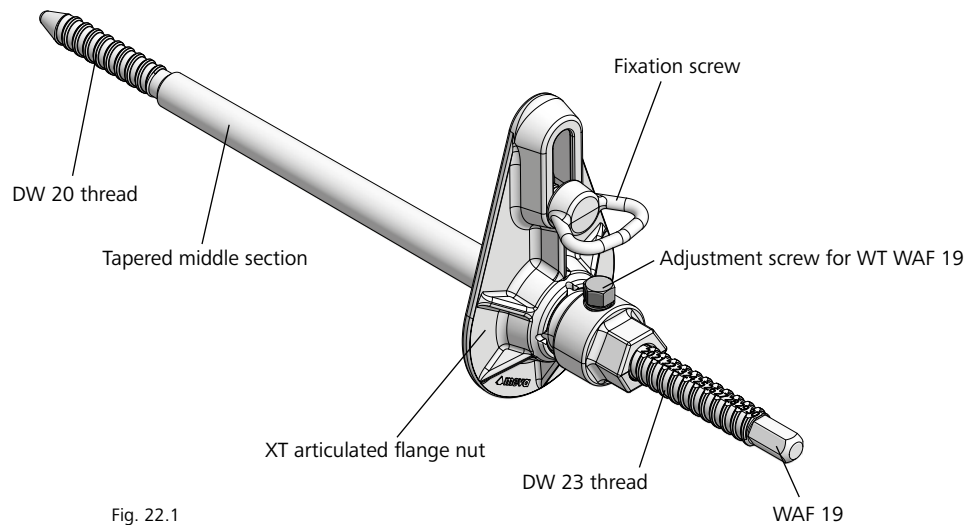

Fig. 22.1

Description	Ref. No.
XT sealing cone 5 AL20	29-902-34
XT sealing cone 5 AL17	29-902-33
XT sealing cone 10 AL20	29-902-35
XT sealing cone 10 AL17	29-902-42
XT taper tie 23/15-25	23-154-60
XT taper tie 23/20-30	23-154-65
XT taper tie 23/35-45	23-154-70
XT taper tie 23/45-55	23-154-75
XT taper tie 23/60-70	23-154-80
XT taper tie ratchet spanner set	29-800-25

Wall Formwork

Single-sided tying with XT taper tie 23

The XT taper tie 23 (Fig. 23.1) has an adjustment screw for wall thicknesses in 0.5 cm increments:

Before setting the wall thickness, the adjustment screw (WAF 19) must be loosened.

To set wall thicknesses in whole centimetres, screw on the XT articulated flange nut until the desired wall thickness can be read off the scale at the end of the shaft (Fig. 23.2). Then tighten the adjustment screw with a ratchet spanner or spanner.

For half centimetres the WT scale must be half visible (Fig. 23.3). The adjustment screw is located on the rear of the shaft. Tighten the adjustment screw with a ratchet spanner or spanner.

A coating of Divinol wax must be applied to the XT taper tie before and after each use.

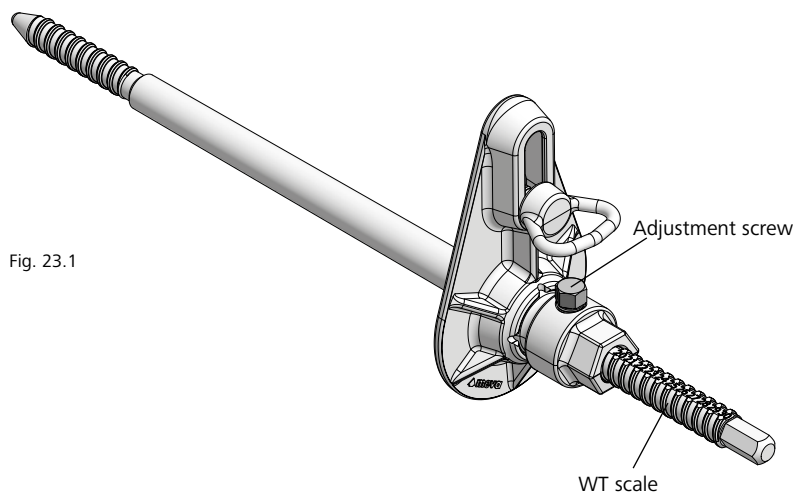

Fig. 23.1

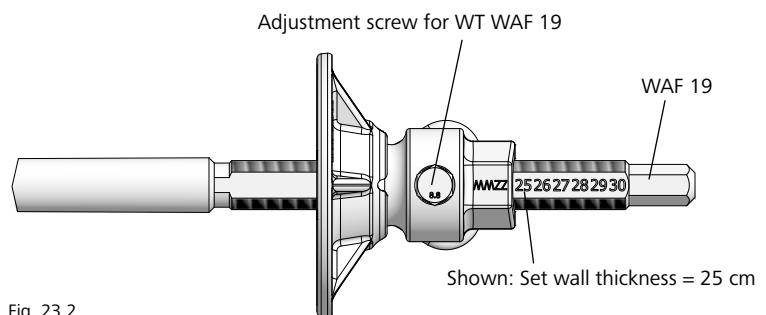

Fig. 23.2

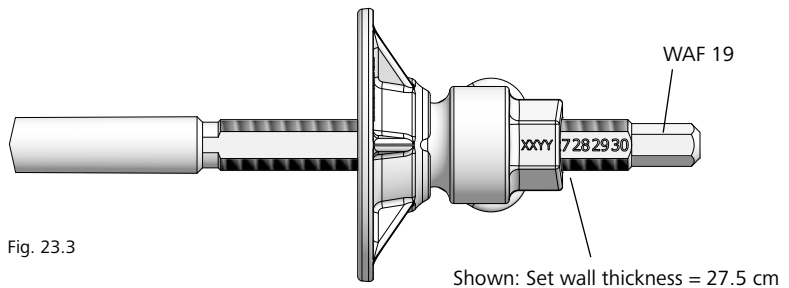

Fig. 23.3

Description	Ref. No.
XT taper tie 23/15-25	23-154-60
XT taper tie 23/20-30	23-154-65
XT taper tie 23/35-45	23-154-70
XT taper tie 23/45-55	23-154-75
XT taper tie 23/60-70	23-154-80
Divinol wax.....	29-203-30

Wall Formwork

Single-sided tying with XT taper tie 20 or 23

Assembly

Before pouring:

1. Place initial-formwork panel (Fig. 24.1 and ST-XT-5), and carry out boxout work (Fig. 24.2).

2. Place final-formwork panel (Fig. 24.3).

3. Prepare the XT taper tie 20 or 23 for the desired wall thickness (see pages ST-XT-21 and 23) and apply a coating of Divinol wax.

4. Push the XT taper tie 20 or 23 through the combination tie hole of the final-formwork side and screw it fully into the combination tie hole of the initial-formwork panel using a ratchet spanner (WAF 17 or 19) (Fig. 24.4). An articulated flange nut on the initial-formwork side and a plastic tube are not required.

5. Secure the XT taper tie 20 or 23 tightly by hand to the multi-function nut of the formwork panel using the fixation screw integrated into the XT articulated flange nut.

Disassembly

After pouring:

6. To strip the formwork, undo the fixation screw on the XT taper tie and screw the tie rod out of the combination tie hole of the initial-formwork panel using a ratchet spanner (WAF 17 or 19).

Note

→ Correct set-up of the formwork to the desired wall thickness is facilitated by using a stop or a mark on the ground which allows the inside formwork to be positioned exactly.

→ The XT taper tie can be screwed in or out using a ratchet spanner. The width across flats is 17 mm (XT taper tie 20) or 19 mm (XT taper tie 23). When screwing the taper tie in, a tightening torque of 200 Nm should not be exceeded.

→ We recommend slackening the articulated flange nut of the XT taper tie approximately 24 hours after pouring the concrete and screwing out the tie rod by approximately half a turn.

→ When stripping, ensure that the XT panel has been completely separated from the concrete before lifting it with the crane.

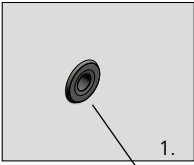

XT sealing cone

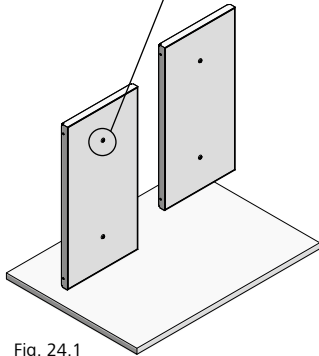

Fig. 24.1

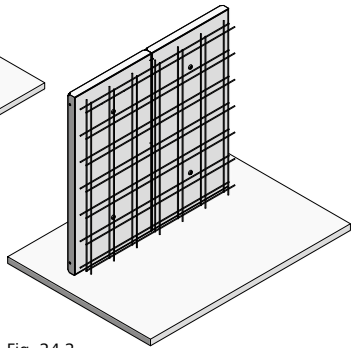

Fig. 24.2

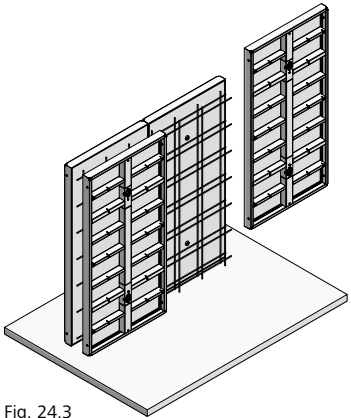

Fig. 24.3

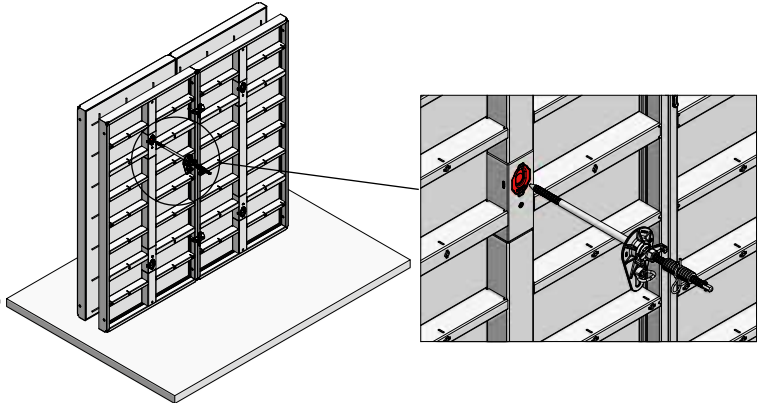

Fig. 24.4

Description	Ref. No.
XT sealing cone 5 AL20	29-902-34
XT sealing cone 5 AL17	29-902-33
XT sealing cone 10 AL20	29-902-35
XT sealing cone 10 AL17	29-902-42
XT taper tie 20/15-25	23-154-10
XT taper tie 20/20-30	23-154-15
XT taper tie 20/35-45	23-154-20
Divinol wax.....	29-203-30

Two-sided tying with DW tie rod and plastic tube

When tying StarTec XT formwork on both sides using DW tie rods and plastic tubes, all combination tie holes in the panels are set to the anchor sleeve position (Fig. 25.1).

StarTec XT is designed for use with the tie rod DW 20.

Note
The XT tie rod DW 20 or the XT taper tie 20 or 23 can also be used in the combination tie hole for two-sided tying with plastic tube.

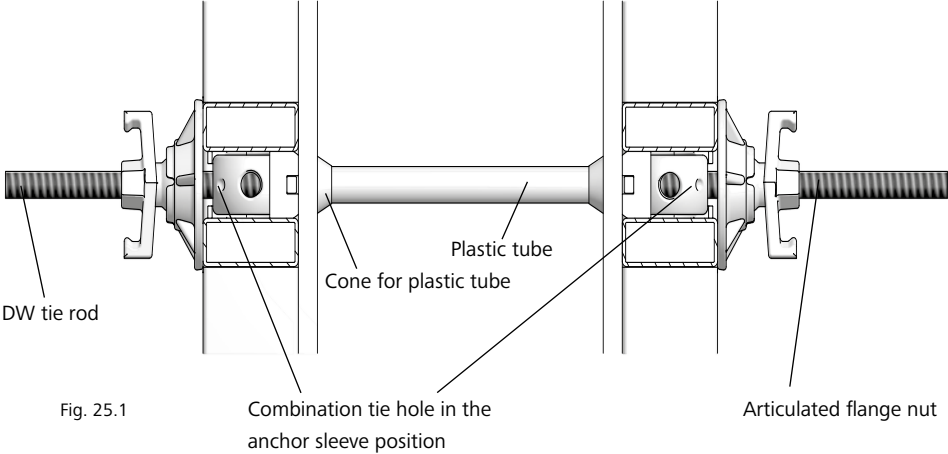

Fig. 25.1

Description	Ref. No.
Tie rod DW 20/120	29-900-97
Articulated flange nut 20/140	29-900-05
Plastic tube D32/200.....	29-902-28
Cone for plastic tube D32/10.	29-902-55

Rules for concrete pouring and rate of placing

The maximum permissible fresh-concrete pressure for StarTec XT is **60 kN/m²**.

Rules for concrete pouring

→ For the rate of placing of walls higher than 2.40 m refer to Table 26.1.

→ According to DIN 4235, concrete should be placed in layers whose thickness can vary from 0.50 m bis 1.00 m.

→ Concrete must not be placed above heights of 1.50 m (or higher) in free fall.

→ When vibrating the concrete, which is done layer by layer, the vibrator must not penetrate more than 50 cm into the layer below.

→ A final vibrating step over the overall concrete height is not recommended. It does not provide any advantage, since concrete that has been vibrated once cannot be compacted further. This may result in water bubbles (shrinkage cavities) on the concrete surface.

Rate of placing

The permissible rate of placing can be precisely determined according to DIN 18218:2010-01 by referring to Table 26.1 or using MEVA's online calculation programme available on the MEVA website.

This and other aids are available at www.meva.net.

Note that you cannot use Table 26.1 unless you know the end of setting of the concrete, t_E . This value can be determined on-site using MEVA's ultrasonic SolidCheck measuring device or knead-bag tests as described in DIN 18218:2010-01. Or simply ask the concrete supplier for the concrete's end of setting.

Maximum rate of placing v_b (depending on the concrete's consistency and end of setting t_E / for walls higher than 2.40 m)* in m/h					
StarTec XT		$t_E = 5$ h	$t_E = 7$ h	$t_E = 10$ h	$t_E = 15$ h
Consistency range	F3	3.00	2.43	1.81	1.14
	F4	2.53	1.76	1.08	0.47
	F5	1.17	0.83	0.58	0.39
	F6	0.92	0.66	0.46	0.31
	SCC	1.06	0.76	0.53	0.35

Table 26.1

* According to DIN 18218:2010-01 (fresh-concrete pressure on vertical formwork)

t_E = End of setting of the concrete

v_b = Maximum rate of placing

Specific values of tie rods DW 15 and DW 20

DW tie rod	15	20
d ₁ [mm]	15	20
d ₂ [mm]	17	22.4
Nominal cross-section [mm ²]	177	314
Permissible working load according to DIN 18216 [kN]	90	160
Tie rod elongation when using the permissible working load [mm/m]	2.5	2.35

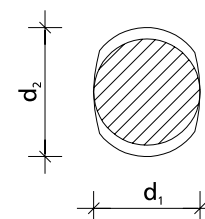

Table 26.2

Specific values of the XT taper ties 20 and 23

XT taper tie	20	23
d ₁ thread tie rod tip [mm]	19.6	19.8
d ₂ thread tie rod tip [mm]	22.0	22.4
d ₁ thread tie rod end [mm]	19.6	23.4
d ₂ thread tie rod end [mm]	22.0	26.0
d ₁ cone	22.5	26.0
d ₂ cone	25.5	29.0
Nominal cross-section [mm ²]	301.7	307.9
Permissible working load according to DIN 18216 [kN]	160	160
Tie rod elongation when using the permissible working load [mm/m]	3	3

Table 26.3

Flatness of surface

The permissible deflection of formwork parts is defined in DIN 18202 (flatness tolerances), Table 3, lines 5 to 7 (Table 27.1). Here, the maximum permissible deflection is defined in relation to the distance between the measuring points. The permissible fresh-concrete pressure that is in line with the flatness tolerances as defined in DIN 18202, Table 3, line 6 is 60 kN/m² for full load.

DIN 18202, Table 3

Column	1	2	3	4	5	6
		Distances as limiting values in mm for distances between measuring points in m				
Line	Reference	0.1	1*	4*	10*	15*
5	Unexposed walls and undersides of slabs	5	10	15	25	30
6	Exposed walls and undersides of slabs, e.g. plastered walls, panelling, suspended ceilings	3	5	10	20	25
7	Like line 6, but with stricter requirements	2	3	8	15	20

The measuring lath is placed on the highest protruding points of the surface and the deflection is measured at the deepest point in-between.

Table 27.1

* Intermediate values can be found in Fig. 27.2. Round up values found to full mm.

The distance between measuring points corresponds to the distance between the highest protruding points.

Flatness tolerances of walls and undersides of slabs

(according to DIN 18202, Table 3)

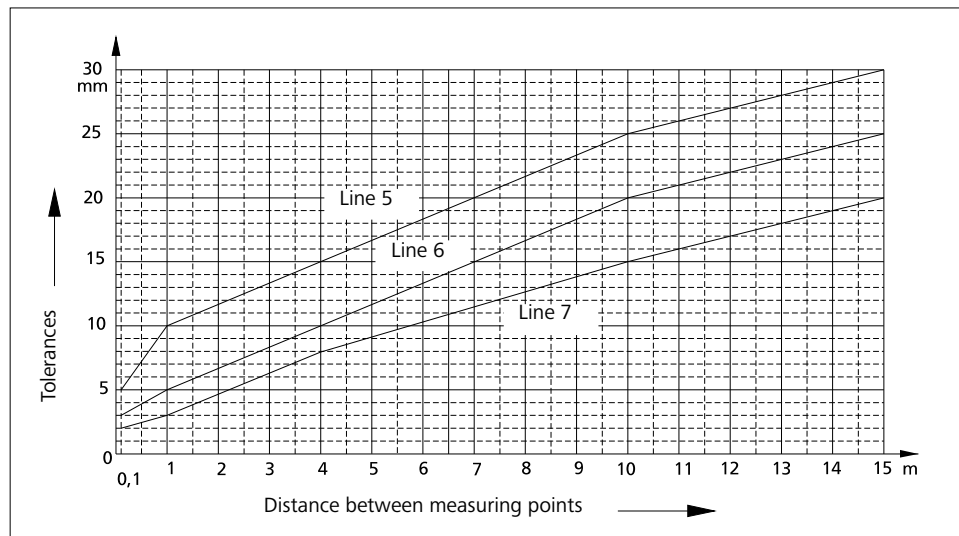

Fig. 27.2

Wall Formwork

Attachment of accessories

All panels are provided with multi-function profiles with welded-in Dywidag-threaded nuts (Figures 28.1, 28.5 and 28.6).

Walkway brackets are provided with integrated self-locking pins (Fig. 28.2) and are mounted on the multi-function profiles and secured with a flange screw 18.

Formwork is set vertically using push-pull props attached to the panel with a flange screw 18 via the formwork-prop connector as shown in Fig. 28.4.

Alignment rails should be attached to the multi-function profiles with flange screws in order to stabilise ganged panels when lifting them by crane, bridge problem areas and brace and stabilise the fillers used to bridge gaps between the panels.

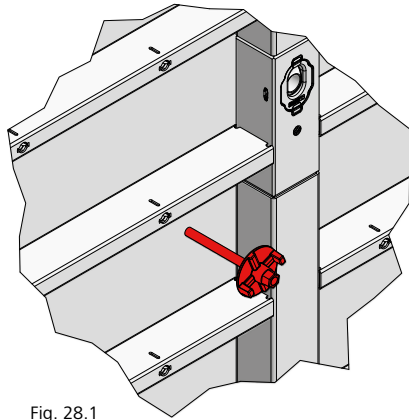

Fig. 28.1

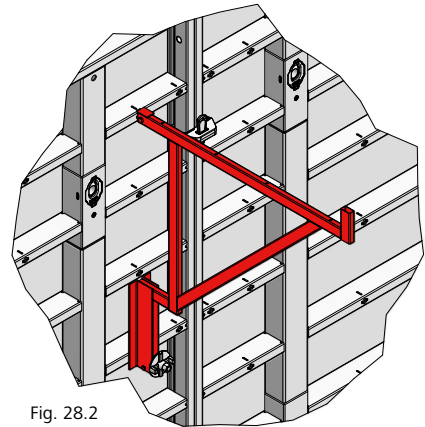

Fig. 28.2

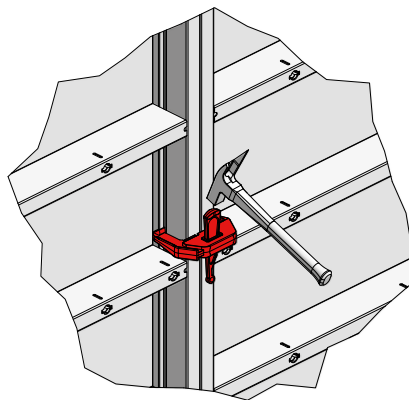

Fig. 28.3

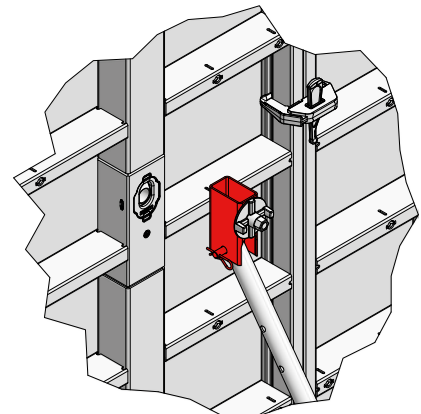

Fig. 28.4

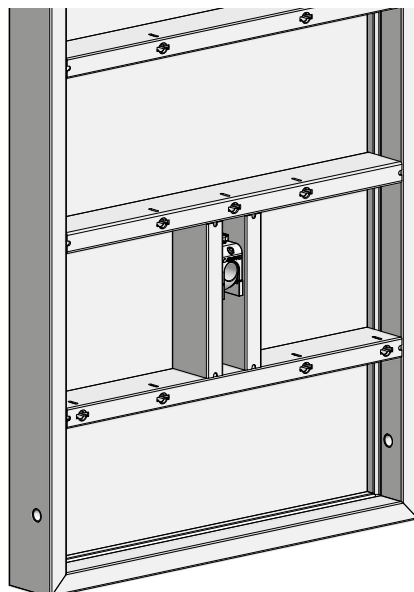

Fig. 28.5

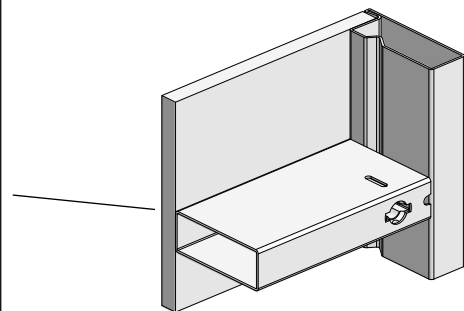

Fig. 28.6

Wall Formwork

Wall braces

The push-pull props or the brace frame 250 with formwork-prop connector are attached to the panel's multi-function profile with flange screw 18 (refer to Figures ST-XT-30.1 and ST-XT-28).

The brace frame 250 is made up of the push-pull prop R 250, the brace SRL 120, two formwork-prop connectors and the double-jointed foot plate.

If push-pull props or brace frames are only used to align the formwork, we recommend a maximum spacing of 4.00 m. In order to withstand wind loads, refer to Table 29.1. For further applications contact MEVA.

Assumptions for Table 29.1

- Wind loads according to DIN EN 1991-1-4
- Wind zone 2, inland (mixed profile between terrain categories II and III)
- Impact pressure $q_p = 0.65$ kN/m² (Table 29.2)
- Pressure coefficient used $c_p = 1.8$
- Exposure time factor $\psi = 0.7$
- Wind pressure $w = q_p \cdot c_p \cdot \psi$
- Formwork on upper edge of terrain
- Values are characteristic values

Description	Ref. No.
Braces SRL	
SRL 120	29-108-80
SRL 170	29-108-90
Push-pull props R	
R 160	29-109-40
R 250	29-109-60
R 460	29-109-80
R 630	29-109-85
Formwork-prop connector	29-804-85
Brace frame 250 with formwork-prop connector	29-109-20
Flange screw 18	29-401-10
Double-jointed foot plate	29-402-32

Wall braces	Formwork height h (m)						
	2.25	2.40	2.70	3.15	3.30	3.60	3.75
Push-pull prop	R250+ SRL120	R250+ SRL120	R250+ SRL120	R250+ SRL120	R250+ SRL120	R460+ SRL170	R460+ SRL170
Permissible influence width e (m)	6.30	3.80	5.35	4.21	3.77	4.04	3.78
Prevailing brace load F_1 (kN)	6.05	4.29	5.99	4.88	4.56	6.06	6.46
Prevailing push-pull prop load F_2 (kN)	11.28	7.22	11.77	12.04	11.50	11.76	10.62
Lifting force V_{Wind} (kN/m)	1.73	2.14	2.08	2.64	2.89	2.68	2.83
Prevailing dowel force V_{dowel} (kN)	14.24	12.58	14.18	14.48	14.78	14.14	14.25
Prevailing dowel force H_{dowel} (kN)	11.59	7.49	11.82	10.86	10.18	11.92	11.60
a (m)*	0.30	0.58	0.337	0.60	0.735	0.30	0.337
b (m)**	1.15	1.08	1.39	1.50	1.50	1.93	1.99

Wall braces	Formwork height h (m)						
	4.05	4.20	4.50	4.65	4.95	5.40	6.00
Push-pull prop	R460+ SRL170	R460+ SRL170	R460+ SRL170	R460+ SRL170	R460+ SRL170	R460+ R250	R460+ R250
Permissible influence width e (m)	3.57	3.31	3.10	2.72	2.48	2.28	2.00
Prevailing brace load F_1 (kN)	5.96	5.46	5.33	4.35	3.77	3.74	3.92
Prevailing push-pull prop load F_2 (kN)	11.85	11.95	12.21	12.13	12.60	12.70	11.88
Lifting force V_{Wind} (kN/m)	3.02	3.36	3.57	4.08	4.54	4.96	5.36
Prevailing dowel force V_{dowel} (kN)	14.17	14.30	14.32	14.69	14.81	14.84	14.04
Prevailing dowel force H_{dowel} (kN)	11.85	11.39	11.44	10.36	10.04	10.08	9.82
a (m)*	0.337	0.60	0.60	1.012	1.24	1.35	1.35
b (m)**	2.17	2.10	2.28	2.12	2.17	2.36	2.71

Table 29.1

* Upper pivot point a, distance measured between top edge of formwork and attachment point of the upper formwork-prop connector

** Distance to the foot plate b, measured from the rear edge of the formwork to the attachment of the foot plate

Wind impact pressure for buildings up to a height of 25 m:

Wind zone	Impact pressure q_p in kN/m ² at a ground elevation within the limits		
	$h \leq 10$ m	$10 \text{ m} < h \leq 18$ m	$18 \text{ m} < h \leq 25$ m
1 Inland	0.50	0.65	0.75
2 Inland	0.65	0.80	0.90
	0.85	1.00	1.10
3 Inland	0.80	0.95	1.10
	1.05	1.20	1.30
4 Inland	0.95	1.15	1.30
	1.25	1.40	1.55
	1.40	-	-

Table 29.2

Wall Formwork

Wall braces

The brace is attached to the double-jointed foot plate (Fig. 30.1) using MEVA quick anchors or anchor bolt, for example.

The permissible influence width of the bracing (e) can be reduced at the edge of the formwork as shown in Fig. 30.3.

→ e = permissible influence width (see Table ST-XT-29.1)

The shoe plate 40 can be used to secure the XT panel to the ground (Fig. 30.4). It can be secured using a MEVA quick anchor or an anchor bolt.

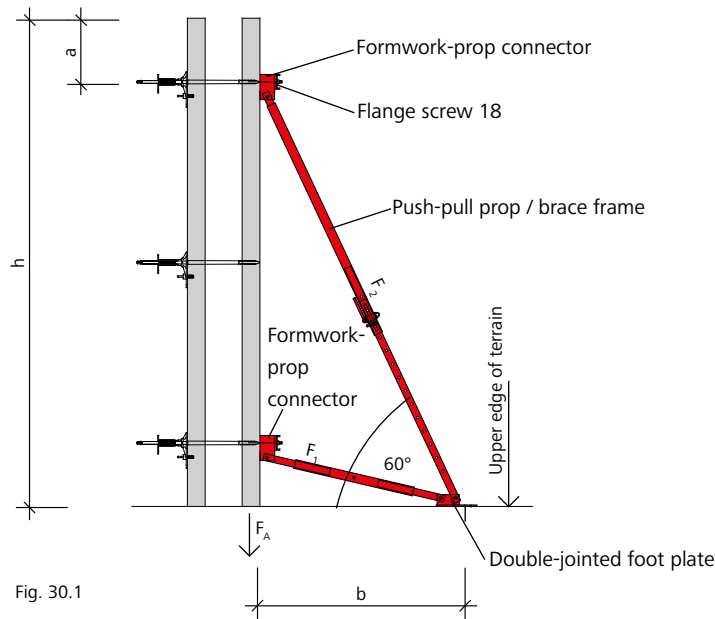

Fig. 30.1

Note:

A restraint mechanism is required when the lifting force $F_A = 1.5 \times V_{Wind} - 0.9 \times G \times h > 0$.

G = weight per unit area of the formwork (including platforms)

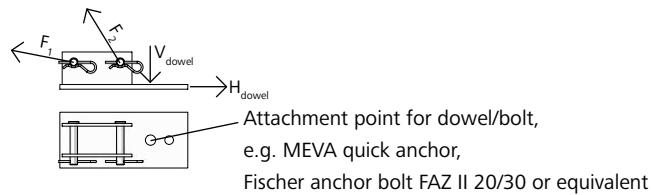

Fig. 30.2 Double-jointed foot plate

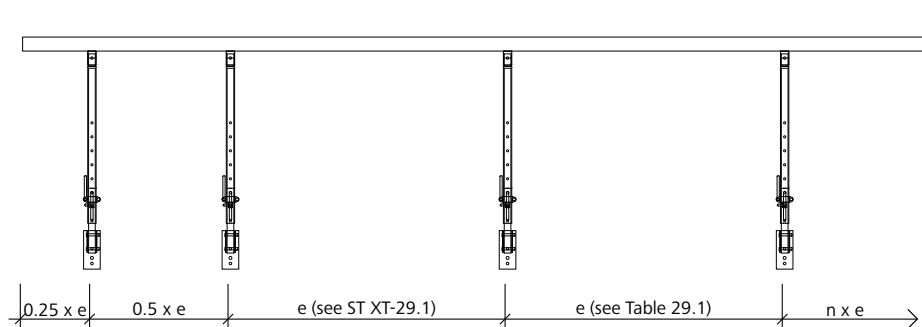

Fig. 30.3

Description	Ref. No.
Braces SRL	
SRL 120	29-108-80
SRL 170	29-108-90
Push-pull props R	
R 160	29-109-40
R 250	29-109-60
R 460	29-109-80
R 630	29-109-85
Formwork-prop connector	29-804-85
Brace frame 250 with formwork-prop connector	29-109-20
Flange screw 18	29-401-10
Double-jointed foot plate	29-402-32
Quick anchor	29-922-70
Shoe plate 40	23-311-92

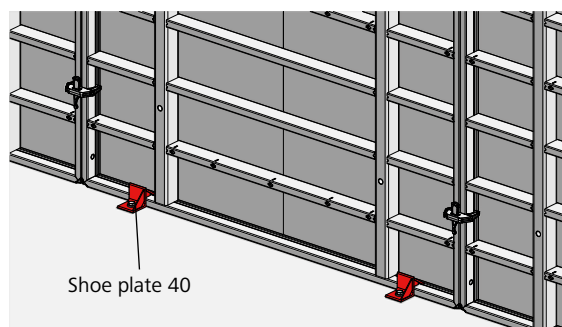

Fig. 30.4

Wall Formwork

Workplaces

The fall height of workplaces must not exceed 2.00 m in accordance with DIN 12811-1.

According to DIN 12811-1 the design of the working scaffold must be as shown in Fig. 31.1. Note that this regulation is valid for Germany. Always observe the federal, state and local regulations of the country where the formwork is used.

Note

Minimum cross section of handrail and midrail (Fig. 31.1):
 for a post spacing up to 2.00 m: 15 x 3 cm
 For a post spacing of up to 3.00 m: 20 x 4 cm or scaffold tube 48 mm.

We recommend the use of safety meshes. They are a quick and safe method to provide fall protection (Fig. 31.2).

Attention

When using our products, the federal, state and local codes and regulations must be observed.

Working scaffold according to DIN 12811-1

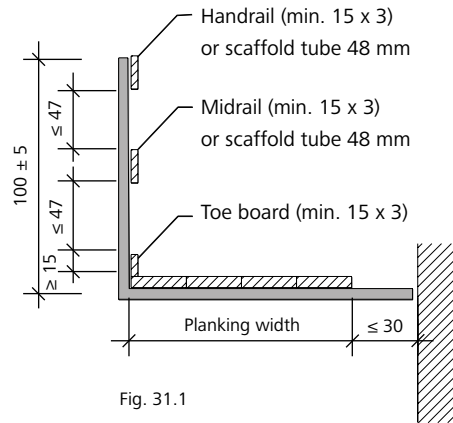

Fig. 31.1

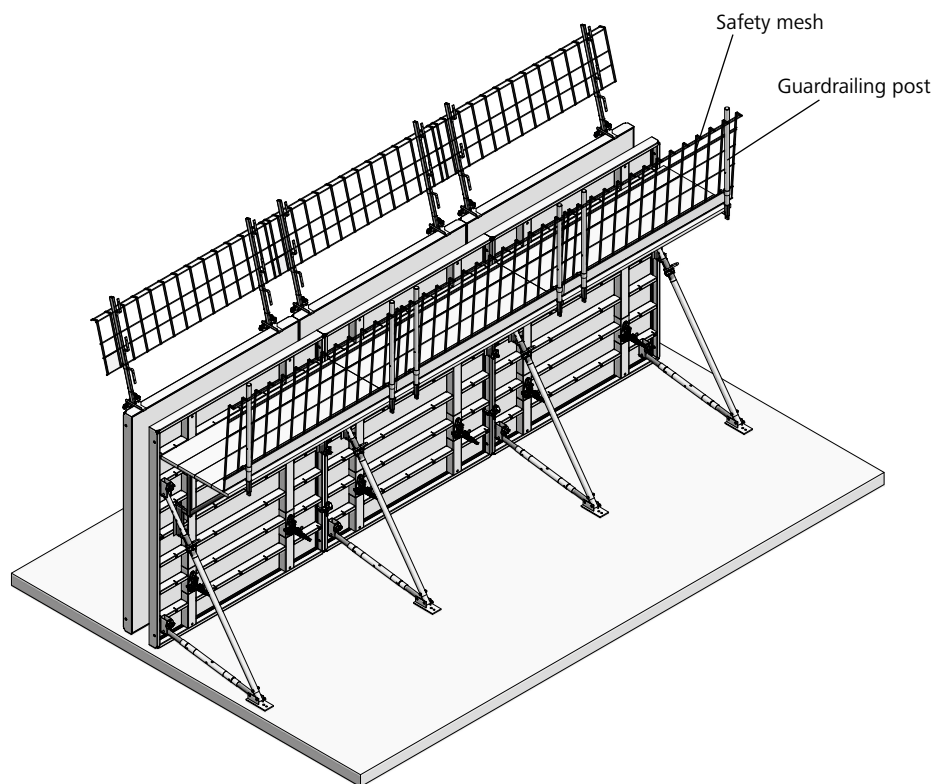

Fig. 31.2

Workplaces – SecuritBasic safety system

MEVA's SecuritBasic is a safety system that provides platforms, ladder access and other safety equipment for safe and efficient work at all heights (Figures 32.1 and 32.2). It prevents falling accidents and at the same time increases work efficiency.

Aluminium SB platforms are available for the StarTec XT panel widths 240 and 135 cm.

Lesser widths are catered for using compensation platforms.

The platforms for panel width 240 are available with and without access hatches. All other platform widths are without access hatch.

SecuritBasic is safely assembled on the ground with the wall formwork panels horizontal.

SecuritBasic can be attached to higher wall formwork whose height has been increased using horizontal or vertical panels.

Please observe the SecuritBasic Technical Instruction Manual.

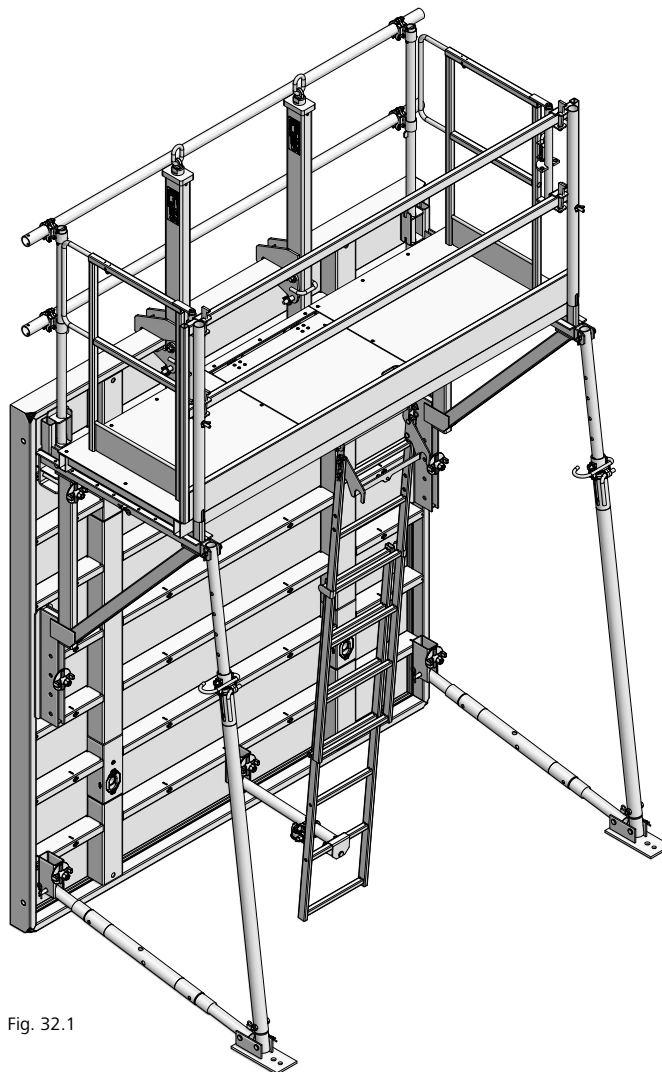

Fig. 32.1

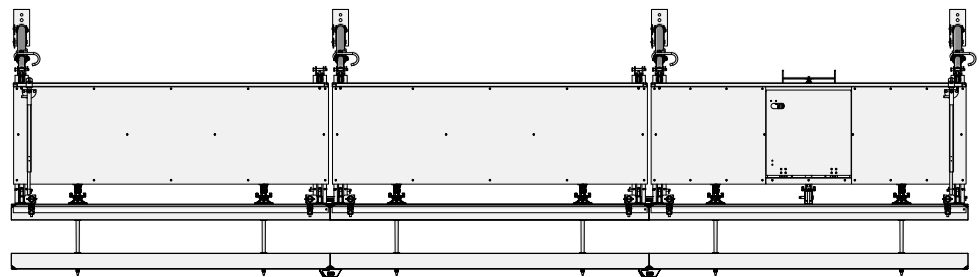

Fig. 32.2

Workplaces – Folding access platform BKB 125

The folding access platform BKB 125 with folding guardrailing provides safe access and a 125 cm wide working platform (Fig 33.1). It enables quick and safe installation of working scaffolds.

The 48 mm thick planks have a rough surface and a metal lining at the edges.

Its length of 235 cm allows the BKB 125/235 to be easily transported, as it fits crosswise on any truck. The stacking height is only 17 cm and the permissible load is 2 kN/m² (200 kg/m²).

The guardrailing can be set to an angle of 90° or 105° (Fig. 33.2). The BKB 125 side railing is mounted to the platform with two flange screws 18.

Attention

Do not crane formwork units when the working platform is attached to the formwork.

To relocate the individual platforms with a crane so that they are all at the same height, we recommend adjusting the length of the chains on the crane sling.

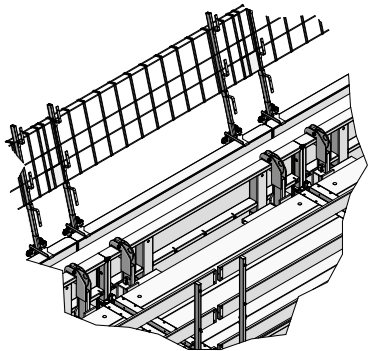

Fig. 33.1

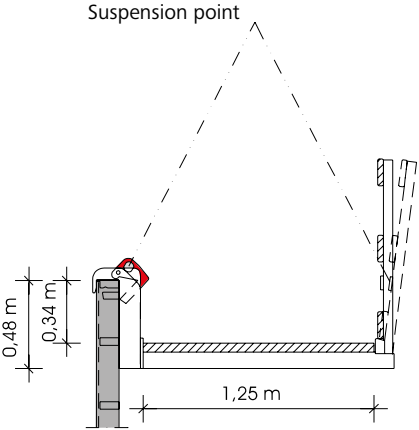

Fig. 33.2

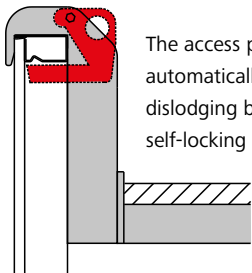

Fig. 33.3

The access platform is automatically secured against dislodging by the integrated self-locking mechanism.

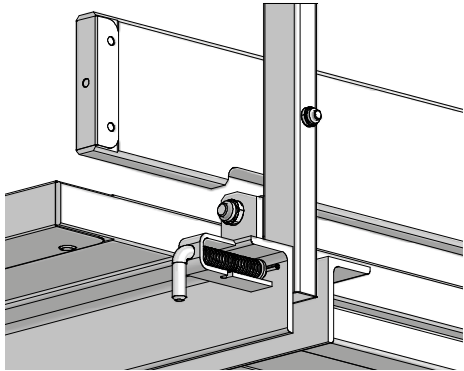

Fig. 33.4

Examples for corner configurations and length compensation

When using our products, the federal, state and local codes and regulations must be observed.

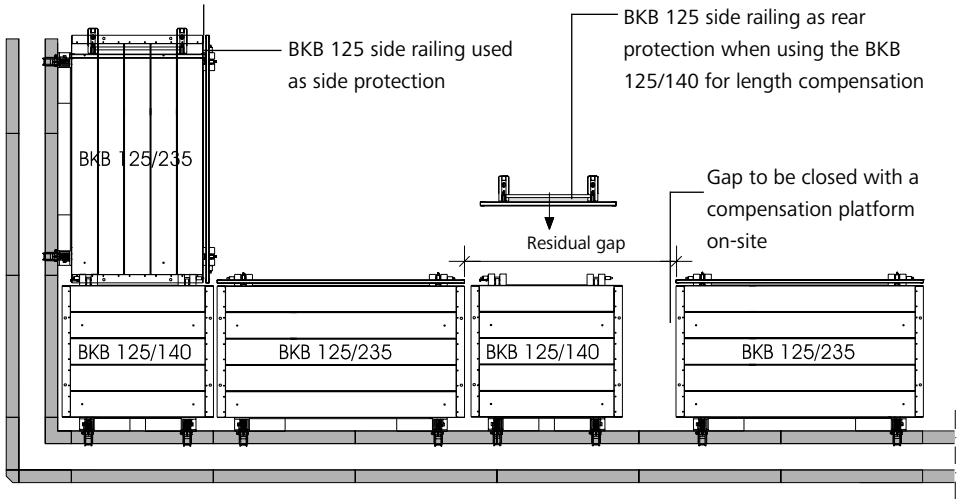

Fig. 33.5

Description	Ref. No.
Folding access platform	
BKB 125/140	29-417-00
BKB 125/235	29-417-10
BKB 125/300	29-417-20
Side railing BKB 125	29-417-30
Flange screw 18	29-401-10

Working scaffolds – Folding access platform BKB 125

When using the BKB folding access platform with 330 cm high StarTec XT panels, tying at the top needs to be done above the panels using Uni-tie claws rather than tying through the top tie holes (Figures 34.1 and 34.2).

Two Uni-tie claws, one DW 15 tie rod and two flange nuts 100 are required per tie connection (Fig. 34.3). We also recommend the use of a plastic tube. It serves as a spacer and protects the tie connection against contamination.

Attention

Unused tie holes must always be closed with plug D35/38 or alternatively with XT sealing cone with a pressed-on plug D20 (see page ST-XT-17).

Note

MEVA's Securit safety system offers platforms, ladder access and other safety equipment for safe and efficient work at all heights. The Securit platforms are fully compatible with the StarTec wall formwork.

Refer to the SecuritBasic and ST Securit technical instruction manuals.

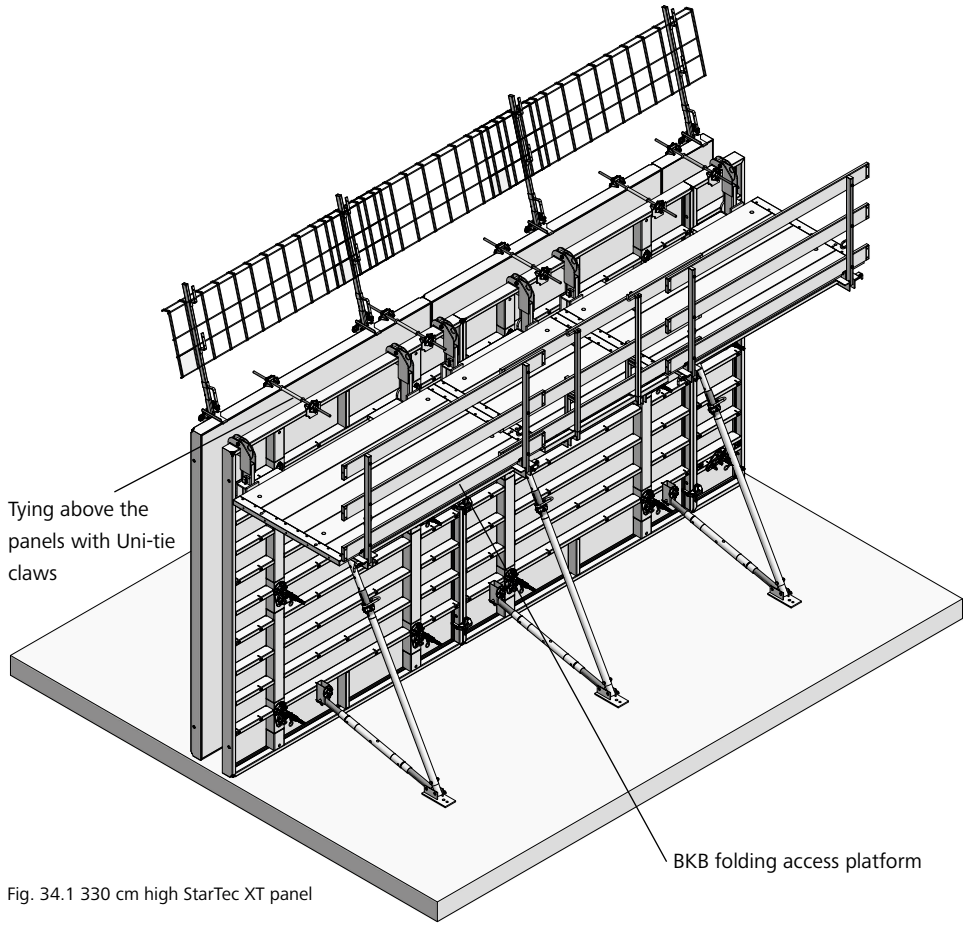

Fig. 34.1 330 cm high StarTec XT panel

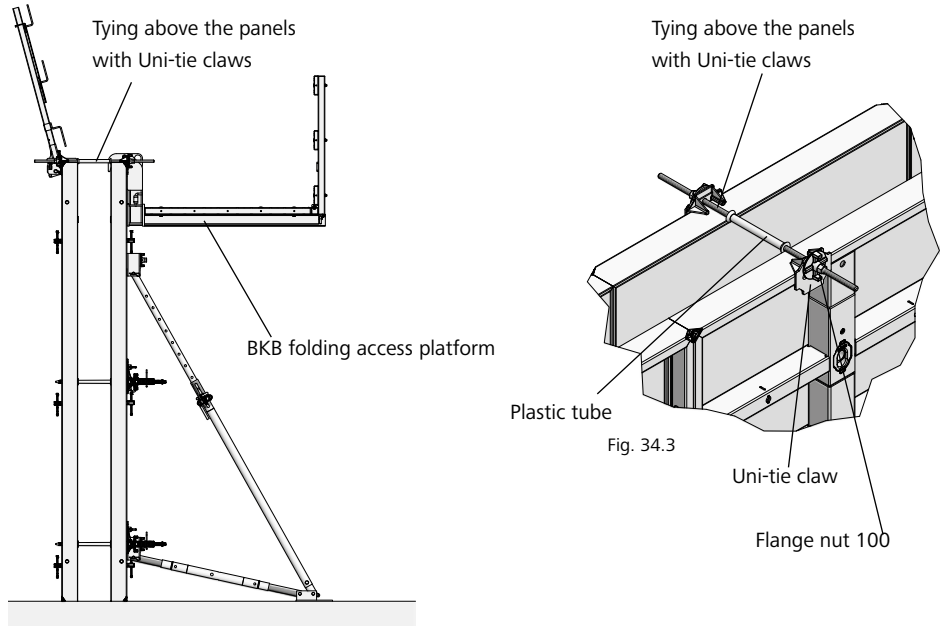

Fig. 34.2

Fig. 34.3

Description	Ref. No.
Tie rod DW 15/90	29-900-80
Flange nut 100	29-900-20
Uni-tie claw	29-901-41
Plug D20	29-902-63
Plug D35/38	29-902-71

Workplaces – Walkway bracket

The pluggable walkway bracket 90 (Fig. 35.1) is mounted to a multi-function profile. To insert the bracket, turn it by 45°, then turn it back to the vertical position and secure it with a flange screw 18 to the multi-function profile below. The planks can then be bolted to the brackets. Maximum bracket spacing for a load of 150 kg/m² (scaffold group 2): 2.50 m according to DIN 12811-1. The minimum thickness of the planks is 4.5 cm and their minimum width is 24 cm.

Guardrailing posts and side railing

The guardrailing posts and the side railing (Figures 35.2 to 35.4) are inserted into the walkway brackets. If the fall height exceeds 2.00 m, a side railing (Fig. 35.4) is required. Note that this regulation is valid for Germany. Always observe the federal, state and local regulations of the country where the formwork is used. We recommend the use of safety meshes with guardrailing posts 48/120 UK. They are quick and safe method to provide fall protection.

The guardrailing post 48/120 UK can be used to allow scaffold tubes to be installed as a fall protection measure. The guardrailing post is made of a round tube with a diameter of Ø 48 mm to attach swivel-joint couplers for the scaffold tubes and a rectangular adapter so that it can be inserted into the walkway bracket (Fig. 35.3).

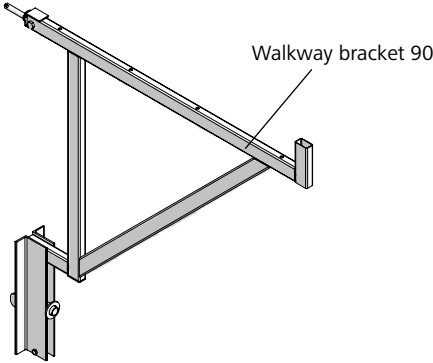

Fig. 35.1

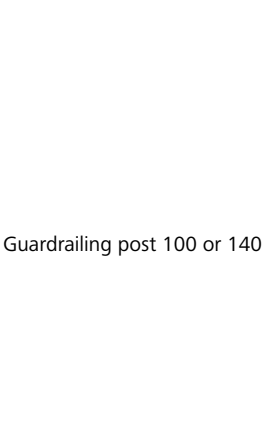

Fig. 35.2

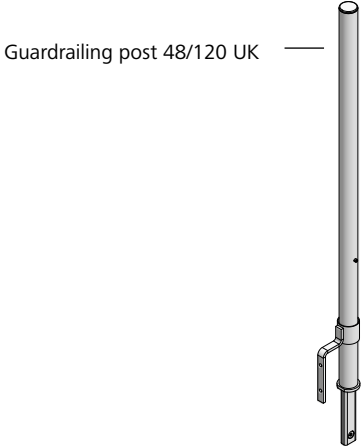

Fig. 35.3

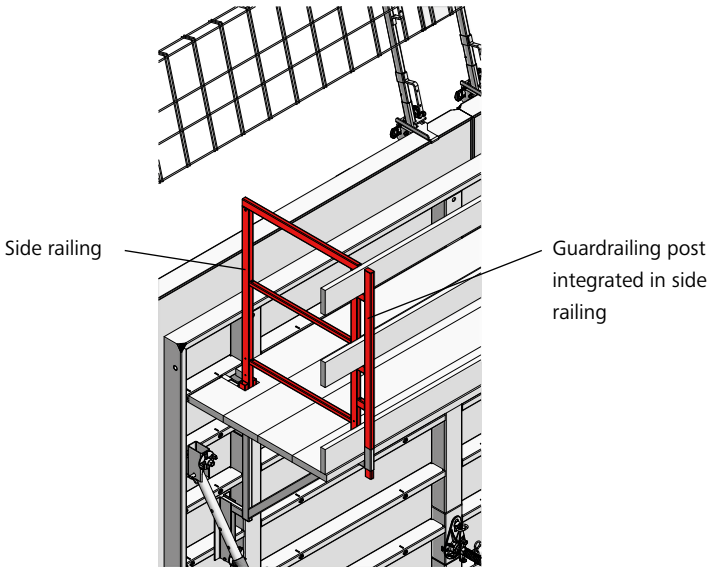

Fig. 35.4

Description	Ref. No.
Walkway bracket 90	29-106-00
Guardrailing post 100	29-106-75
Guardrailing post 140	29-106-85
Guardrailing post 48/120 UK	29-106-80
Side railing 90/100.....	29-108-20
Swivel-joint coupler 48/48	29-412-52
Scaffold tube 48/200	29-412-23
Scaffold tube 48/300	29-412-26
Scaffold tube 48/400	29-412-27
Scaffold tube 48/500	29-412-25
Scaffold tube 48/600	29-412-28
Safety mesh 1100/2490.....	29-920-00
Safety mesh 600/2490.....	29-920-05

Workplaces – Ladder fixture for wall formwork

The ladder fixture for wall formwork enables a ladder or an extension ladder to be firmly attached to the horizontal or vertical wall formwork panel and thus ensures safe access to the working scaffold, e.g. walkway bracket or BKB folding access platform.

The upper ladder fixture for wall formwork is attached to a multi-function nut of the formwork panel with the integrated flange screw. This is used to hook on the ladder. The integrated safety lever prevents the ladder lifting out accidentally.

The lower ladder fixture for wall formwork is attached to the bottom of the wall formwork panel with the integrated flange screw. It is used to secure the ladder.

Both the ladder and the extension ladder can be equipped with a safety cage.

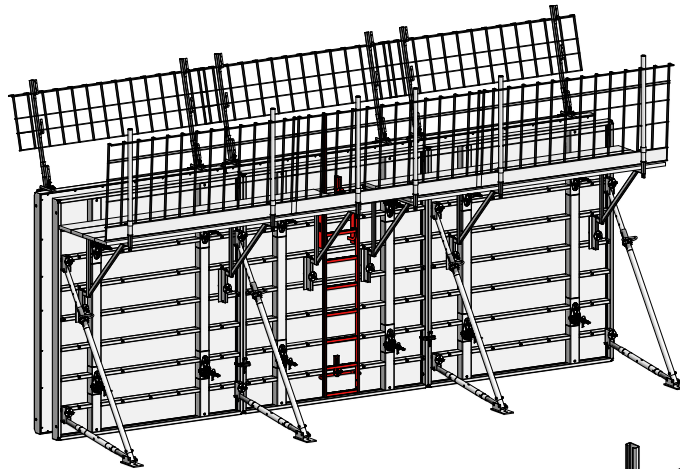

Fig. 36.1

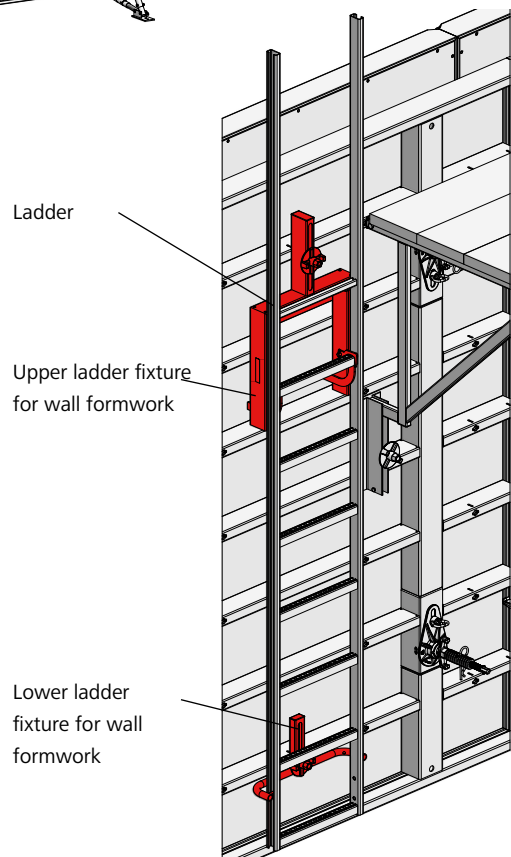

Fig. 36.2

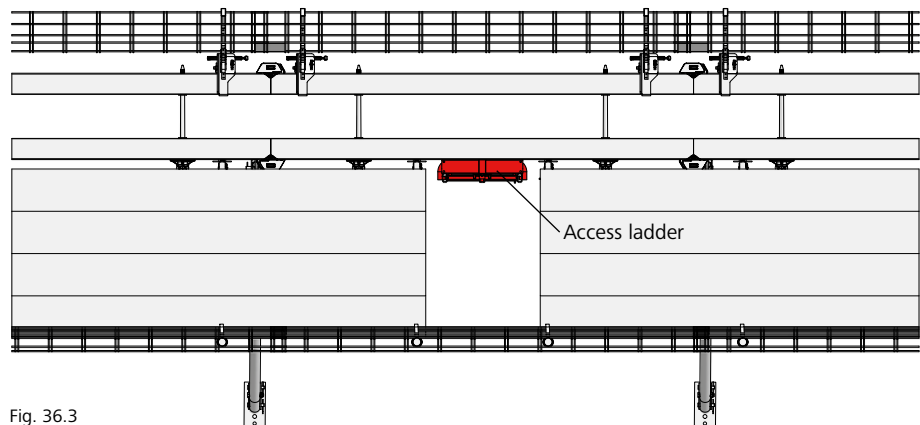

Fig. 36.3

Description	Ref. No.
Ladder fixture for wall formwork	
upper.....	29-416-82
lower.....	29-416-84
Ladder 348.....	29-414-50
Ladder 318.....	29-414-55
Ladder 243.....	29-416-50
Extension ladder 270.....	29-416-52
Extension ladder 210.....	29-414-60
Extension ladder 120.....	29-416-55
Extension ladder 90.....	29-416-60
Extension ladder 60.....	29-416-62
Ladder connector.....	29-414-70
Safety cage 210.....	29-414-85
Safety cage 85.....	29-414-90
Safety cage 40.....	29-416-90

Workplaces – Tilting bracket 40/60

An additional fall protection device on the opposite side of the working scaffolds, i.e. on the other side of the formwork, is required for heights above 2.00 m. Note that this regulation is valid for Germany. Make sure to observe the federal, state and local regulations of the country where the formwork is used.

The tilting bracket 40/60 (Fig. 37.1) is designed for the MEVA wall formwork systems Mammut XT, Mammut 350, Mammut, StarTec XT and StarTec/AluStar and is used to attach MEVA guardrailing posts to create a fall protection system.

It is attached to the panel's frame profile with the integrated wedge (Fig. 37.2).

MEVA guardrailing posts 100, 140 and 48/120 UK can be connected to the bracket.

The tilting bracket can be turned so that it is vertical to facilitate the installation of safety meshes or railing boards. It can also be tilted by 15° to create sufficient room for the concrete bucket (Fig. 37.2).

One guardrailing post per bracket must be ordered separately.

Plug-in support for:
MEVA guardrailing posts 100, 140 and 48/120 UK

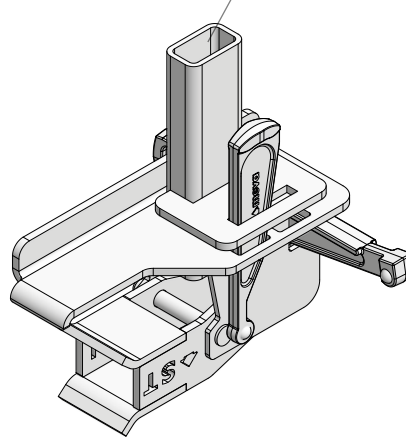

Fig. 37.1

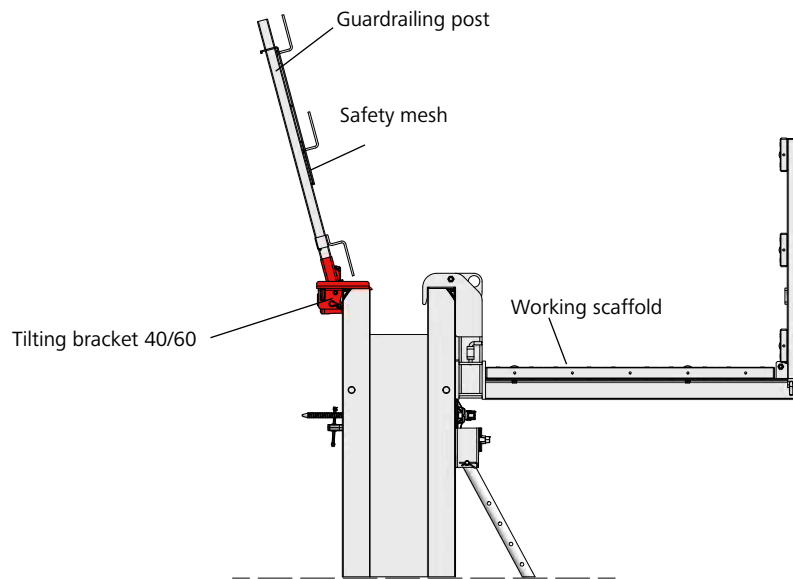

Fig. 37.2

Description	Ref. No.
Tilting bracket 40/60.....	29-920-82
Guardrailing post 100.....	29-106-75
Guardrailing post 140.....	29-106-85
Guardrailing post 48/120 UK ..	29-106-80

Wall Formwork

Crane Hook

The permissible load of a AS crane hook (Fig. 38.1) is 15 kN (1.5 t).

Handling

1. Open the safety lever as far as possible (Fig. 38.3).
2. Push the crane hook over the panel profile until the claw engages completely in the groove.
3. Release the safety lever and press it back to its start position so that the crane hook is locked completely (Fig. 38.4).

Attention

Always use two crane hooks, even when moving single panels. Always attach the crane hooks symmetrically to the centre of gravity.

The opening angle of the crane sling must not exceed 60° (Figures 38.5 and 38.6).

When moving single horizontal panels, both crane hooks must be attached at the centre of gravity over the cross stiffeners of the profile. When moving several panels at once, make sure each crane hook is attached at a panel joint (Fig. 38.6). This prevents the crane hook slipping.

When to replace the crane hook

If the reference dimension exceeds 41 mm, the crane hook must be replaced immediately. This also applies if only one side of the hook exceeds this dimension (Fig. 38.2).

Safety check

Always check the crane hook before use. Do not overload the crane hook. Exceeding the permissible loading can result in excessive elongation and thus permanent deformation. A damaged crane hook is not capable of supporting the full load and its safe use can no longer be guaranteed.

Safety regulations

Strictly observe the accident prevention regulations that apply in your country.

Also observe the operating instructions delivered with the crane hook.

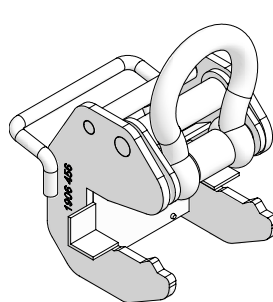

Fig. 38.1

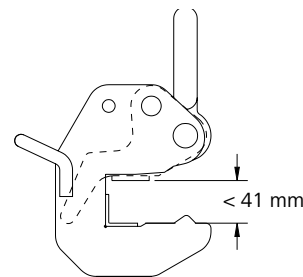

Fig. 38.2

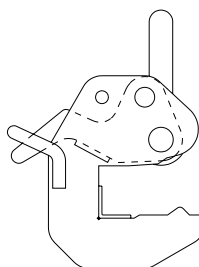

Fig. 38.3

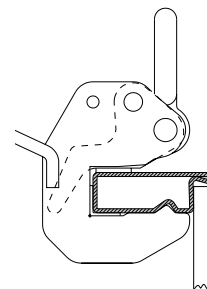

Fig. 38.4

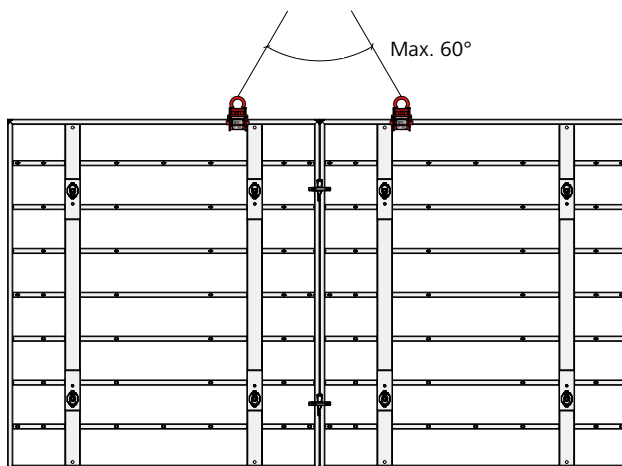

Fig. 38.5

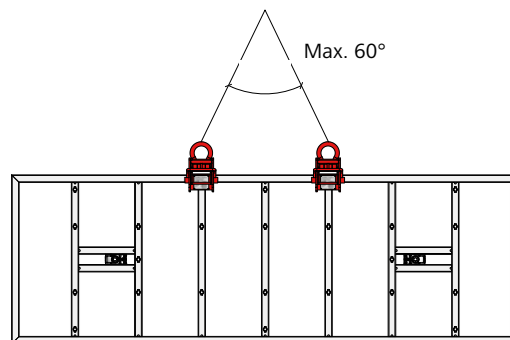

Fig. 38.6

Description	Ref. No.
AS crane hook	29-203-89

Wall Formwork

90° corner

With StarTec XT, a 90° corner can be produced for all wall thicknesses (WT). To do this, three outer-corner sizes (Figures 39.1 and 39.2) and one inner-corner size (Figures 39.3 and 39.4) are available for use in conjunction with standard StarTec XT panels.

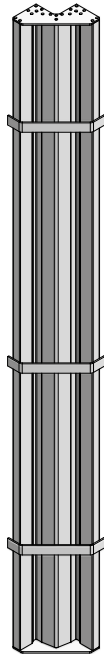

Fig. 39.1

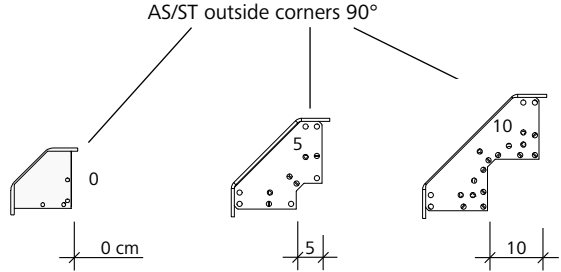

Fig. 39.2

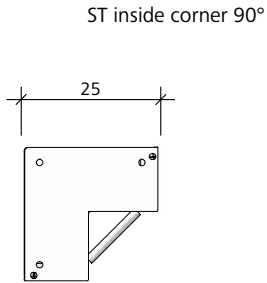

Fig. 39.3

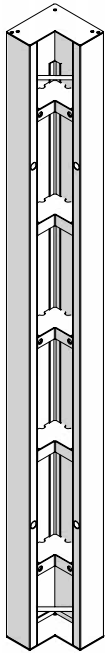

Fig. 39.4

Description	Ref. No.
AS/ST outside corner	
330 Alu	22-140-10
330/5 Alu	22-140-15
330/10 Alu	22-140-48
270 Alu	22-140-20
270/5 Alu	22-140-25
270/10 Alu	22-140-50
135 Alu	22-140-30
135/5 Alu	22-140-35
135/10 Alu	22-140-52
ST inside corner	
330/25 AL	21-251-00
270/25 AL	21-251-05
135/25 AL	21-251-35

Wall Formwork

90° corner

To create 90° corners, StarTec XT standard panels with widths 45 and 60 cm are used in conjunction with ST inner and AS/ST outside corners (Figures 40.1 to 40.6).

The system parts required for the most common wall thickness are listed in Table 40.7.

If different wall thicknesses meet, the AS/ST aluminium filler can be used to close the residual gap (Figures 40.8 and 40.9). The filler has tie holes. DW tie rods are used on both sides when using the tie holes in the filler. For stabilisation, a cross stiffener 44 must be attached with two flange screws 18 at each tie hole level (Fig. 40.9).

Different wall thickness can also be compensated for using job-built wood fillers (see pages ST-XT-42 and 54).

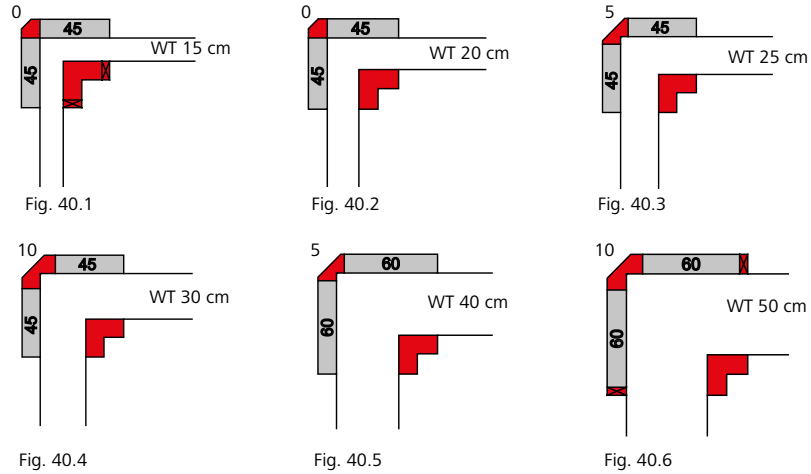

Corner combinations

WT (in cm)	AS/ST outside corners 90°			ST inside corner 90°	StarTec XT panels		AS/ST filler
	OC 0	OC 5	OC 10	IC 25	45	60	5
15	1			1	2		2 (inside)
20	1			1	2		
25		1		1	2		
30			1	1	2		
35	1			1		2	
40		1		1		2	
45			1	1		2	
50			1	1		2	2 (outside)

Table 40.7

Description	Ref. No.
AS assembly lock	29-205-00
Uni-assembly lock 22	29-400-85
Uni-assembly lock 28	29-400-90
M cross stiffener 44	29-401-02
Flange screw 18	29-401-10
AS/ST aluminium filler 330/4 ..	21-270-54
AS/ST aluminium filler 330/5 ..	21-270-58
AS/ST aluminium filler 330/6 ..	21-270-56
AS/ST aluminium filler 330/8 ..	21-270-57
AS/ST aluminium filler 270/4 ..	21-270-59
AS/ST aluminium filler 270/5 ..	21-270-60
AS/ST aluminium filler 270/6 ..	21-270-61
AS/ST aluminium filler 270/8 ..	21-270-62
AS/ST aluminium filler 135/4 ..	21-270-64
AS/ST aluminium filler 135/5 ..	21-270-65
AS/ST aluminium filler 135/6 ..	21-270-66
AS/ST aluminium filler 135/8 ..	21-270-67
AS/ST timber profile	
330/21	29-200-07
270/21	29-200-03
135/21	29-200-05
SA 270/27	29-200-04
SA 135/27	29-200-06

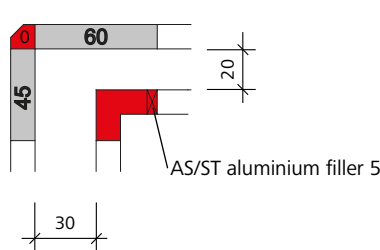

Fig. 40.8

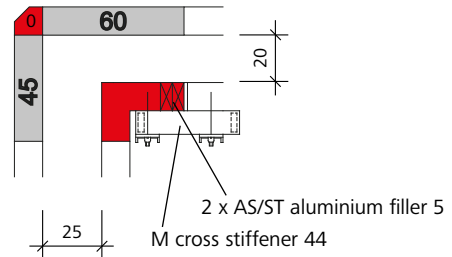

Fig. 40.9

Wall Formwork

90° corner

For single-sided tying at the corner, any XT panel, except panel width 135 cm, can be installed next to the ST inside corner and next to the StarTec XT panel opposite (45 or 60 cm wide) (Figures 41.1 to 41.4). For the number of assembly locks required for an AS/ST outside corner refer to pages ST-XT-43 and 44.

Attention

Unused tie holes must always be closed with plug D35/38 or alternatively with XT sealing cone with a pressed-on plug D20 (see page ST-XT-17).

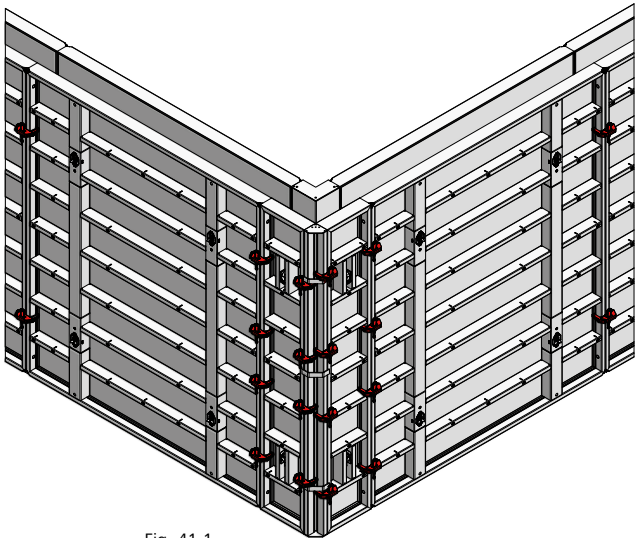

Fig. 41.1

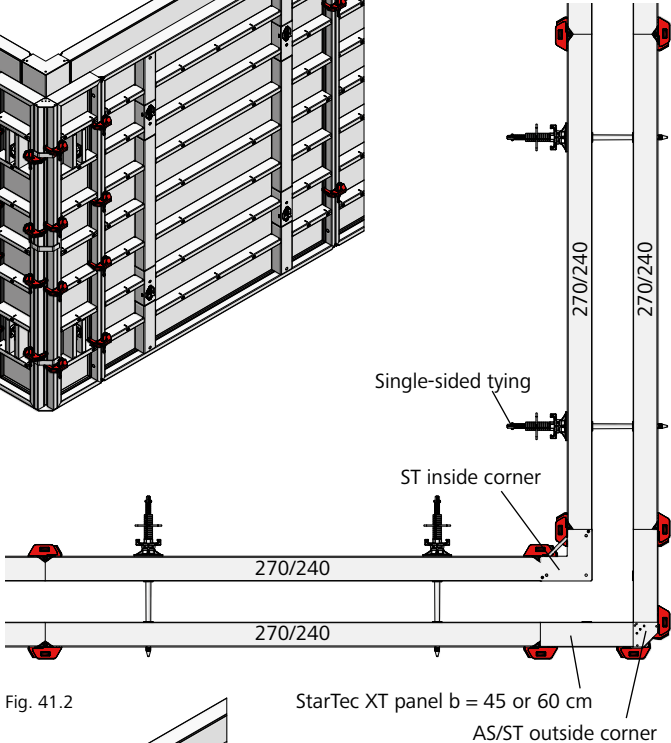

Fig. 41.2

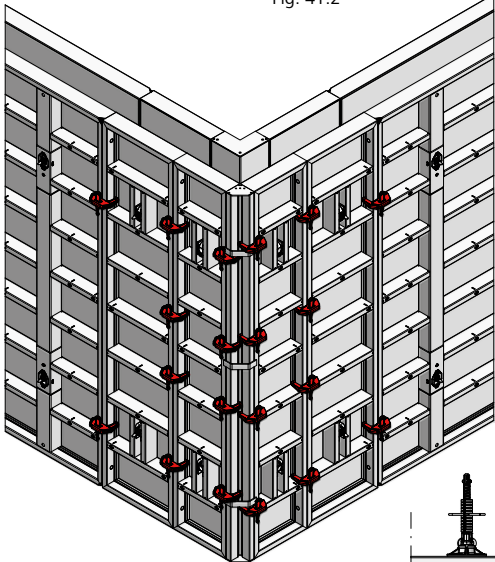

Fig. 41.3

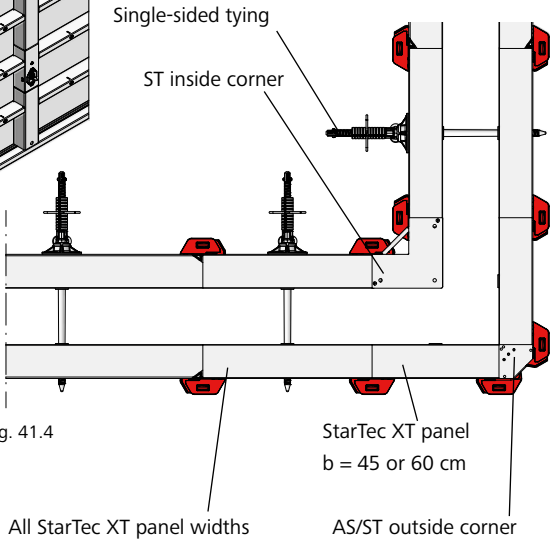

Fig. 41.4

Description	Ref. No.
Flange screw 18.....	29-401-10
XT sealing cone 5 AL20	29-902-34
XT sealing cone 5 AL17	29-902-33
XT sealing cone 10 AL20	29-902-35
XT sealing cone 10 AL17	29-902-42
Plug D35/38	29-902-71
Plug D20, red.....	29-902-63

All StarTec XT panel widths (except when width = 135 cm)

Wall Formwork

90° corner – ST inside corner

The ST inside corner is galvanised and has an alkus all-plastic facing.

Like a standard panel, the inside corner (Fig. 42.1) requires only three assembly locks per side for height 330 cm; all other heights require two assembly locks per side. The side length is 25 cm (Fig. 42.2), see page ST-XT-39.

Inside corner with wood filler

The connection is achieved with three Uni- or RS assembly locks for height 330 cm and with two assembly locks for all other heights. For stabilisation, a cross stiffener 44 must be attached with the flange screw 18 to the multifunction profiles at each tie hole level (Fig. 42.3).

Wide wood filler:

- RS assembly lock from 0 to 12.5 cm
- Uni-assembly lock 22 from 0 to 14 cm
- Uni-assembly lock 28 from 0 to 20 cm

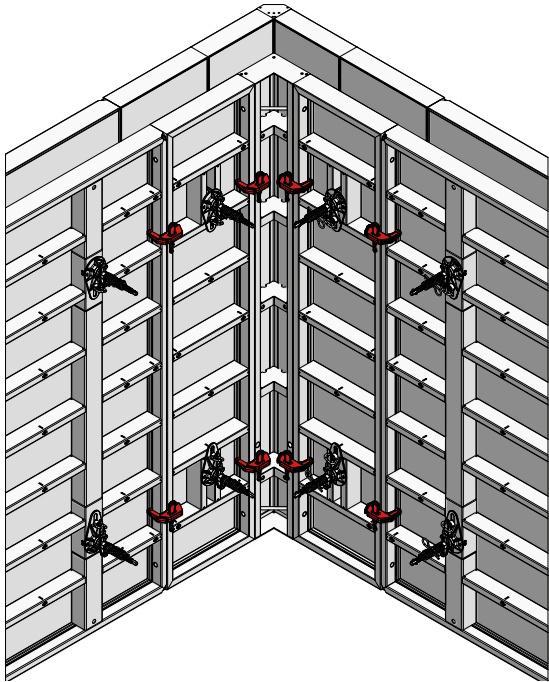

Fig. 42.1

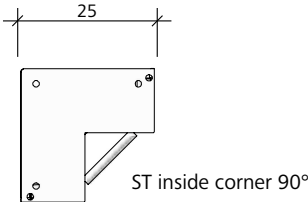

Fig. 42.2

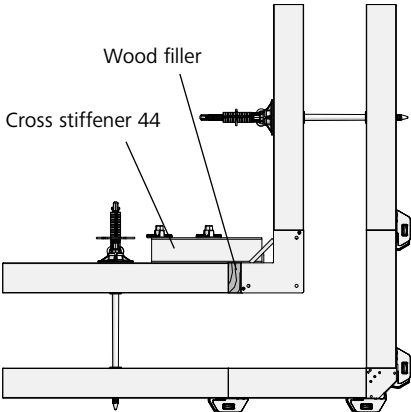

Fig. 42.3

Description	Ref. No.
AS assembly lock	29-205-00
Uni-assembly lock 22	29-400-85
Uni-assembly lock 28	29-400-90
RS assembly lock.....	23-807-70
M cross stiffener 44	29-401-02
Flange screw 18.....	29-401-10

90° corner – AS/ST outside corner

The AS/ST outside corners 0, 5 and 10 (Fig. 43.2) together with the StarTec XT panels and the AS assembly lock result in a solid 90° outside corner solution (Figures 43.1 and 43.2 and page ST-XT-39).

For the number of AS assembly locks required for a AS/ST outside corner (a), for the next panel joint (b) as well as for the standard panel joint (c) up to a wall thickness (WT) of 30 cm refer to Table 43.4. For the assembly locks and alignment rails required for height-extended AS/ST outside corners refer to page ST-XT-44.

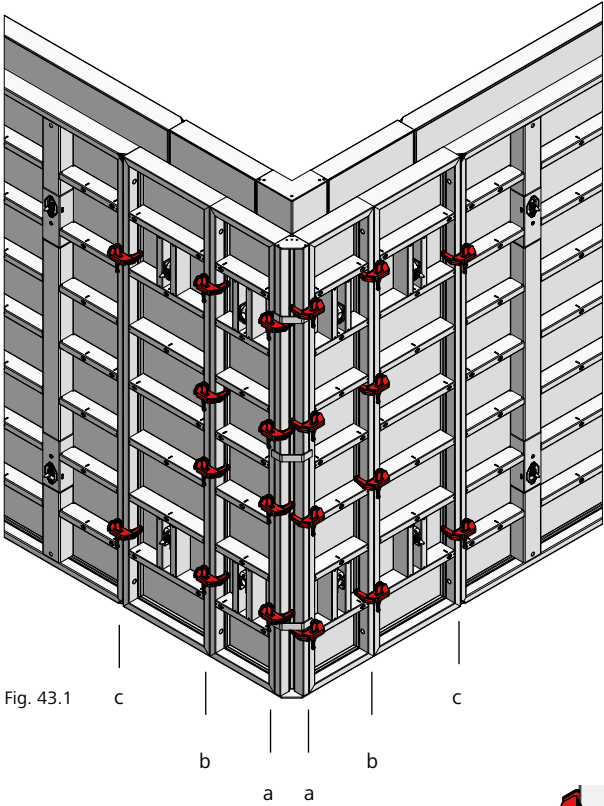

Fig. 43.1

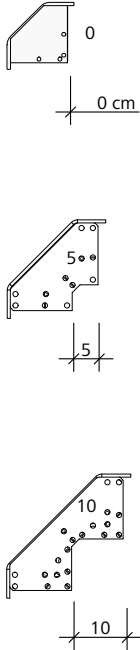

Fig. 43.2

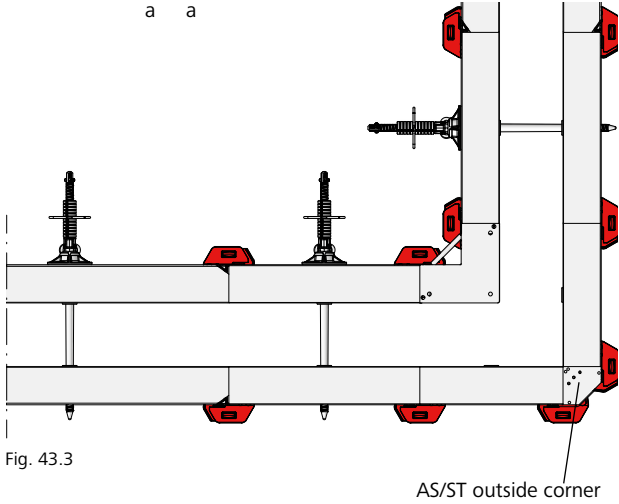

Fig. 43.3

AS/ST outside corner

Pouring height (in cm)	Number of AS assembly locks (up to WT = 30 cm)		
	(a)	(b)	(c)
360	7	6	4
330	6	6	4
300	5	5	3
270	4	4	2
135	2	2	2

Table 43.4

Description	Ref. No.
M cross stiffener 44	29-401-02
AS assembly lock	29-205-00
Uni-assembly lock 22	29-400-85
Uni-assembly lock 28	29-400-90
M outside corner bracket	23-137-63
Flange screw 18	29-401-10

90° corner – Height-extended AS/ST outside corner

For the number of AS assembly locks required for an AS/ST outside corner (a), for the next panel joint (b) as well as for the standard panel joint (c) on height-extended AS/ST outside corners up to a wall thickness (WT) of 30 cm refer to Table 44.2.

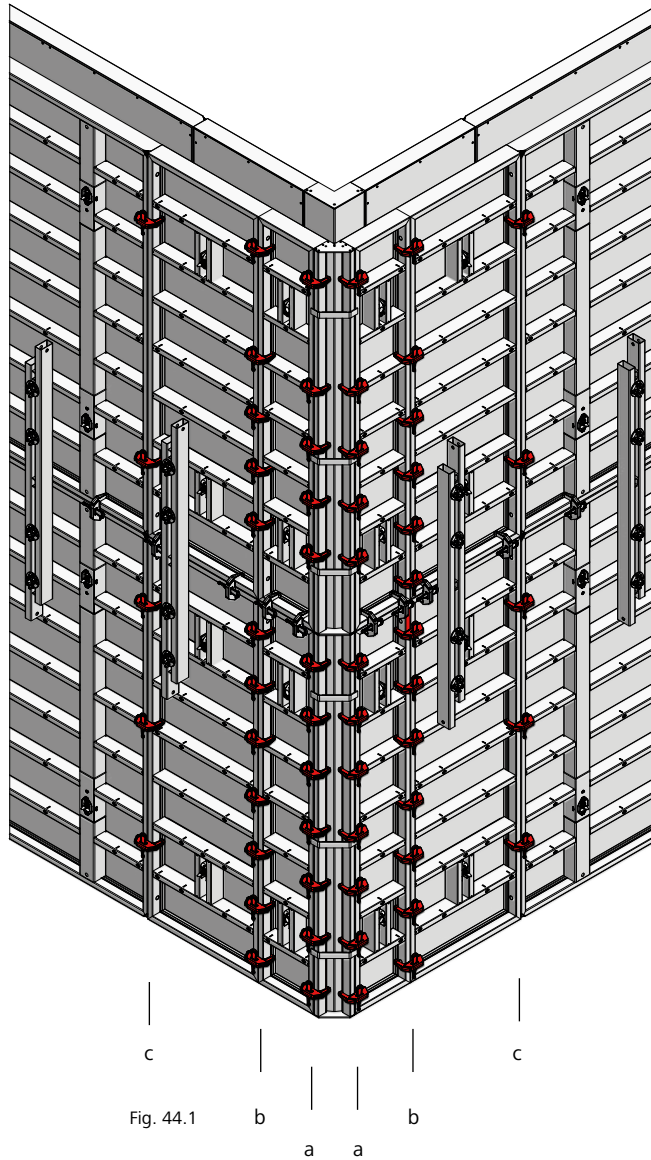

Fig. 44.1

Panel height (in cm)	Number of AS assembly locks (up to WT = 30 cm)		
	(a)	(b)	(c)
660	16 (9+7)	16 (9+7)	6 (3+3)
600	15 (8+7)	15 (8+7)	6 (3+3)
540	12 (7+5)	12 (7+5)	5 (3+2)
495	11 (7+4)	11 (7+4)	5 (3+2)
405	9 (7+2)	9 (7+2)	4 (2+2)

Table 44.2

Description	Ref. No.
M alignment rail 250	29-402-50
M alignment rail 180	29-400-92
AS alignment rail 125	29-201-75
AS alignment rail 50	29-201-73
Flange screw 18.....	29-401-10

Wall Formwork

Hinged corner

Acute and obtuse angled corners are formed using hinged inside and outside corners (Figures 45.1 and 45.2).

At the outside corner, alignment rails must be attached to the multi-function profiles of the adjacent panels using flange screws.

If the inside angle is greater than 100°, alignment rails and a wooden blocking are required on the inside (Fig. 45.1).

Timber fillers and Uni-assembly locks 22 are used for length compensation.

Side length

- Outside corner 7.5 cm
- Inside corner 30 cm

Adjustment range

60° to 180°

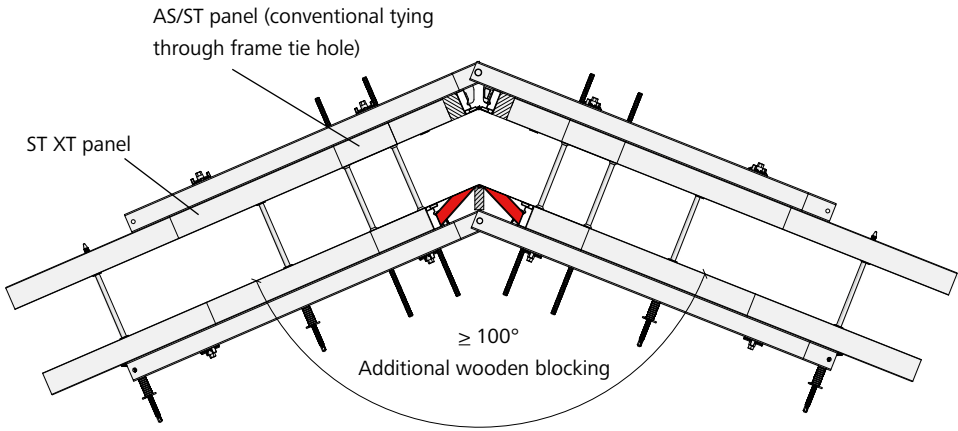

Fig. 45.1

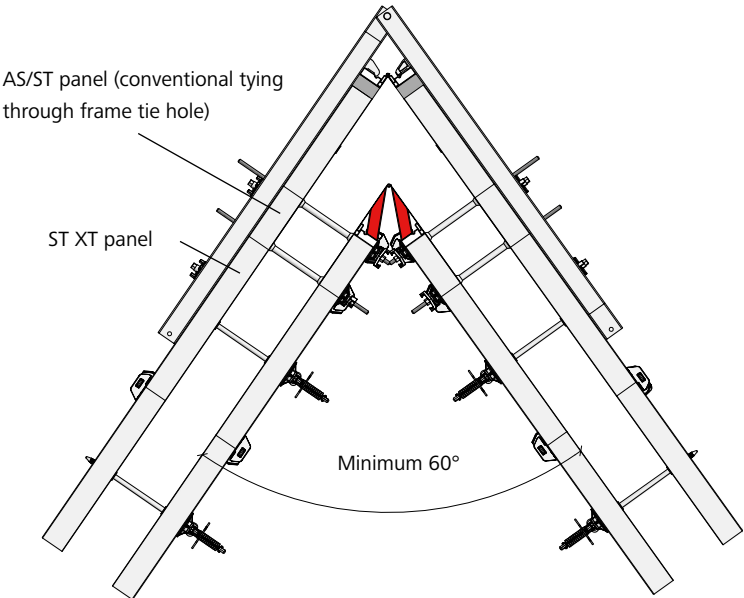

Fig. 45.2

Description	Ref. No.
Hinged inside corner	
StarTec HIC 330/30	21-270-20
AluStar HIC 270/30	21-270-00
AluStar HIC 135/30	21-270-10
Hinged outside corner	
StarTec HOC 330/7.5	21-280-20
AluStar HOC 270/7.5	21-280-00
AluStar HOC 135/7.5	21-280-10

Wall Formwork

Hinged corner

If the inside angle α is less than 100° , alignment rails and a wooden blocking are not required on the inside (Fig. 46.1).

Table 46.2 shows the different filler areas Y (filler) depending on the wall thickness (WT) and the inside angle α .

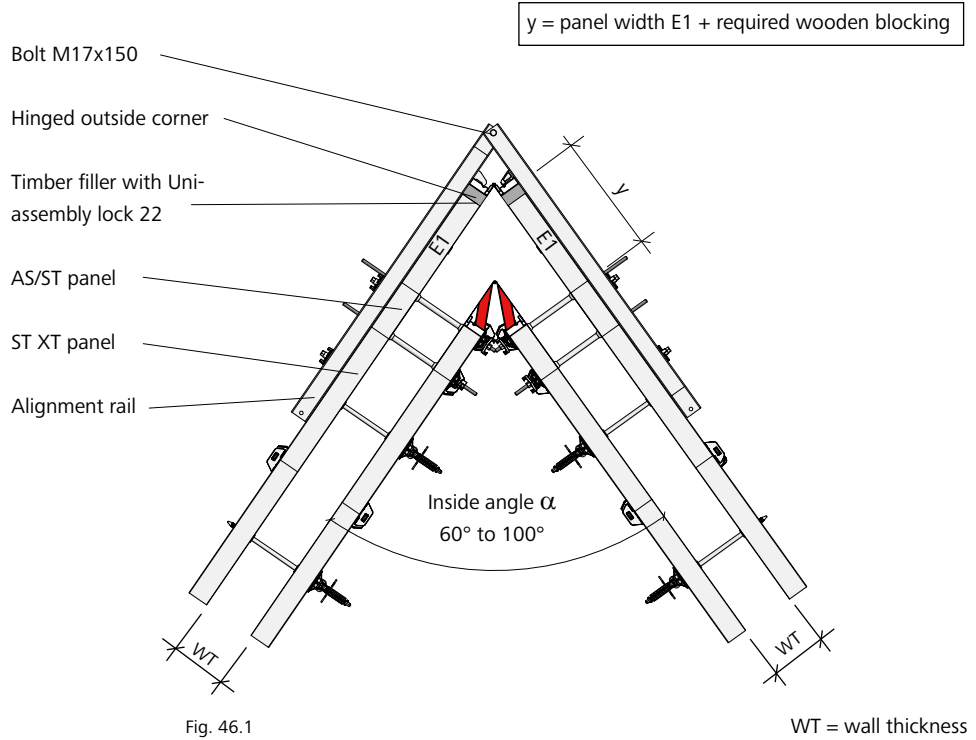

$$\text{Equation to calculate the width } y \text{ (in cm)} = \frac{WT}{\tan \frac{\alpha}{2}} + 22.5 \text{ [cm]}$$

Inside angle (α)	Wall thickness (WT)						
	24 cm	25 cm	30 cm	35 cm	40 cm	45 cm	50 cm
60°	Y = 64.1	Y = 65.8	Y = 74.5	Y = 83.1	Y = 91.8	Y = 100.4	Y = 109.1
65°	Y = 60.2	Y = 61.7	Y = 69.6	Y = 77.4	Y = 85.3	Y = 93.1	Y = 101.0
70°	Y = 56.8	Y = 58.2	Y = 65.3	Y = 72.5	Y = 79.6	Y = 86.8	Y = 93.9
75°	Y = 53.8	Y = 55.1	Y = 61.6	Y = 68.1	Y = 74.6	Y = 81.1	Y = 87.7
80°	Y = 51.1	Y = 52.3	Y = 58.3	Y = 64.2	Y = 70.2	Y = 76.1	Y = 82.1
85°	Y = 48.7	Y = 49.8	Y = 55.2	Y = 60.7	Y = 66.2	Y = 71.6	Y = 77.1
90°	Y = 46.5	Y = 47.5	Y = 52.5	Y = 57.5	Y = 62.5	Y = 67.5	Y = 72.5
95°	Y = 44.5	Y = 45.4	Y = 50.0	Y = 54.6	Y = 59.2	Y = 63.7	Y = 68.3
100°	Y = 42.6	Y = 43.5	Y = 47.7	Y = 51.9	Y = 56.1	Y = 60.3	Y = 64.5
105°	Y = 40.9	Y = 41.7	Y = 45.5	Y = 49.4	Y = 53.2	Y = 57.0	Y = 60.9
110°	Y = 39.3	Y = 40.0	Y = 43.5	Y = 47.0	Y = 50.5	Y = 54.0	Y = 57.5
115°	Y = 37.8	Y = 38.4	Y = 41.6	Y = 44.8	Y = 48.0	Y = 51.2	Y = 54.4
120°	Y = 36.4	Y = 36.9	Y = 39.8	Y = 42.7	Y = 45.6	Y = 48.5	Y = 51.4
125°	Y = 35.0	Y = 35.5	Y = 38.1	Y = 40.7	Y = 43.3	Y = 45.9	Y = 48.5
130°	Y = 33.7	Y = 34.2	Y = 36.5	Y = 38.8	Y = 41.2	Y = 43.5	Y = 45.8
135°	Y = 32.4	Y = 32.9	Y = 34.9	Y = 37.0	Y = 39.1	Y = 41.1	Y = 43.2
140°	Y = 31.2	Y = 31.6	Y = 33.4	Y = 35.2	Y = 37.1	Y = 38.9	Y = 40.7
145°	Y = 30.1	Y = 30.4	Y = 32.0	Y = 33.5	Y = 35.1	Y = 36.7	Y = 38.3
150°	Y = 28.9	Y = 29.2	Y = 30.5	Y = 31.9	Y = 33.2	Y = 34.6	Y = 35.9
155°	Y = 27.8	Y = 28.0	Y = 29.2	Y = 30.3	Y = 31.4	Y = 32.5	Y = 33.6
160°	Y = 26.7	Y = 26.9	Y = 27.8	Y = 28.7	Y = 29.6	Y = 30.4	Y = 31.3
165°	Y = 25.7	Y = 25.8	Y = 26.4	Y = 27.1	Y = 27.8	Y = 28.4	Y = 29.1
170°	Y = 24.6	Y = 24.7	Y = 25.1	Y = 25.6	Y = 26.0	Y = 26.4	Y = 26.9
175°	Y = 23.5	Y = 23.6	Y = 23.8	Y = 24.0	Y = 24.2	Y = 24.5	Y = 24.7
180°	Y = 22.5	Y = 22.5	Y = 22.5	Y = 22.5	Y = 22.5	Y = 22.5	Y = 22.5

Table 46.2

Description	Ref. No.
M alignment rail 250	29-402-50
M alignment rail 180	29-400-92
Flange screw 18	29-401-10
Uni-assembly lock 22	29-400-85
Uni-assembly lock 28	29-400-90

Wall Formwork

Stripping corner

The ST stripping corners 330, 270 and 135 allow the shaft formwork to be removed safely and quickly from the poured shaft walls, for example, without damaging the walls or formwork. They function according to the “jumping jack” principle.

The stripping corner is a three-piece design to permit inward movement of the lateral parts.

The side length is 25 cm.

The height of the stripping corner can be increased easily (Fig. 47.1).

After pouring and when the concrete has set sufficiently, all stripping corners are activated (pages ST-XT-50 to -52) and the entire formwork can be lifted out of the shaft as one single unit with a 4-rope crane sling (Fig. 47.3). There is no need to disassemble the formwork. For details see Figures 47.4 A and 47.5 B.

Note

- Before pouring, cover the joint on the sides of the stripping corners with adhesive tape to make them easier to clean.
- Make sure the entire formwork is completely removed from the poured walls before lifting it by crane.

Attention

When slinging with several strands, only two strands may be considered to be load-bearing according to the Berufsgenossenschaft (the German employers' liability insurance association). This does not apply if it has been ensured that the load is distributed evenly over further strands or if the permissible loading of the individual strands is not exceeded in the event of an unequal load distribution.

The maximum permissible loading of the crane eye per stripping corner is 10 kN (1 ton). This results in a permissible total weight of the complete shaft formwork of 40 kN (4 tons) if it has been ensured that the load is evenly distributed (the contractor is responsible for this). Otherwise, the permissible total weight is 20 kN (2 tons). The permissible loading of the AS crane hook is 15 kN (1.5 tons). This results in a permissible total weight of the complete shaft formwork of 60 kN (6 tons) if it has been ensured that the load is evenly distributed (the contractor is responsible for this). Otherwise, the permissible total weight is 30 kN (3 tons). For higher loads, a spreader beam must be used.

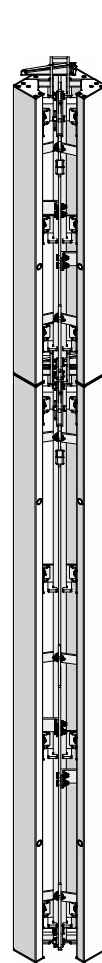

Fig. 47.1

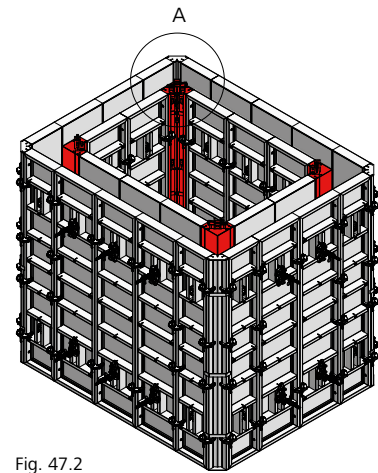

Fig. 47.2

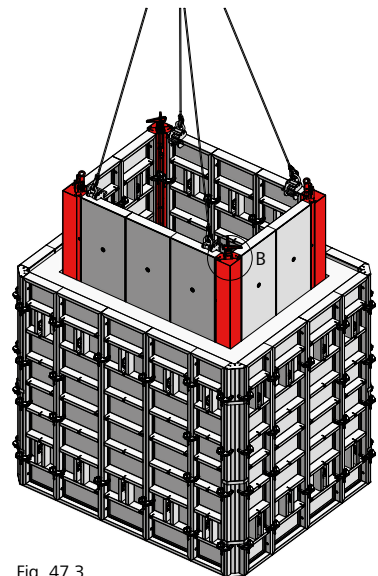

Fig. 47.3

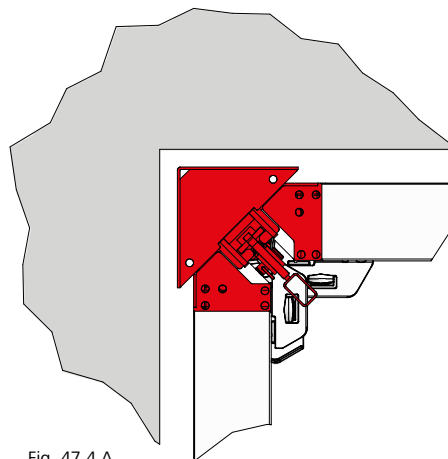

Fig. 47.4 A

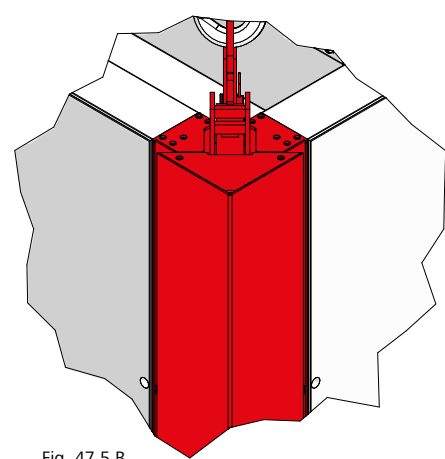

Fig. 47.5 B

Description	Ref. No.
Stripping corner	
StarTec SC 330/25.....	21-262-05
StarTec SC 270/25.....	21-262-10
StarTec SC 135/25.....	21-262-30

Stripping corner

Attachment and position of assembly locks

The function of the ST stripping corners is ensured when the AS assembly locks are fitted to the stripping corner in the permitted areas.

No assembly locks can be attached and positioned in the shaded areas.

Height 330 cm requires three assembly locks (Fig. 48.1).

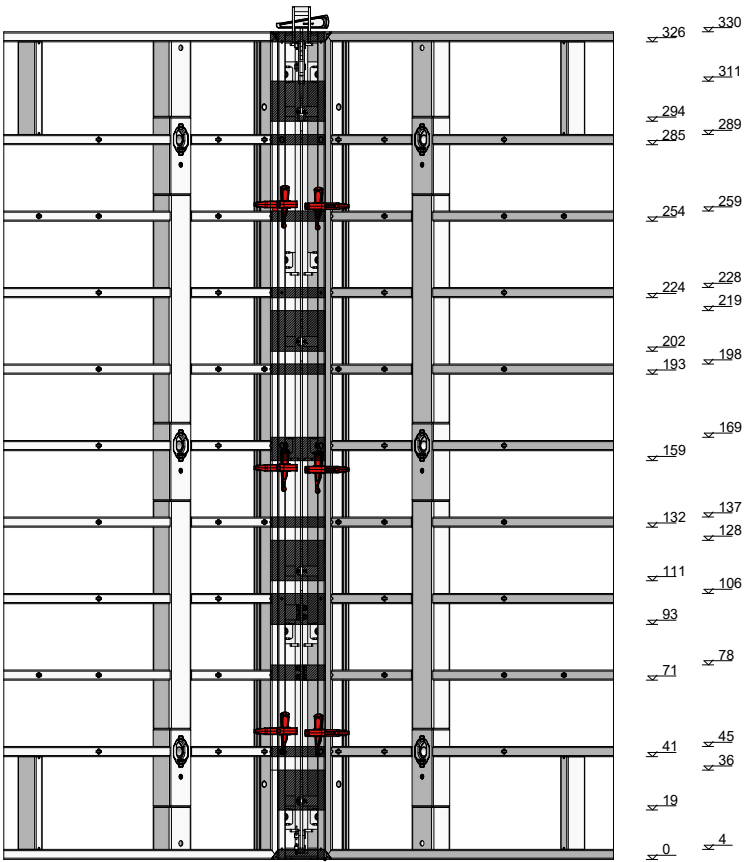
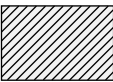

Fig. 48.1 ST stripping corner 330/25



No assembly locks possible in grey shaded areas!

Description	Ref. No.
Stripping corner StarTec SC 330/25.....	21-262-05

Wall Formwork

Stripping corner

Attachment and position of assembly locks

The function of the ST stripping corners is ensured when the AS assembly locks are fitted to the stripping corner in the permitted areas.

No assembly locks can be attached and positioned in the shaded areas.

Up to a height of 270 cm two assembly locks are required (Figures 49.1 and 49.2).

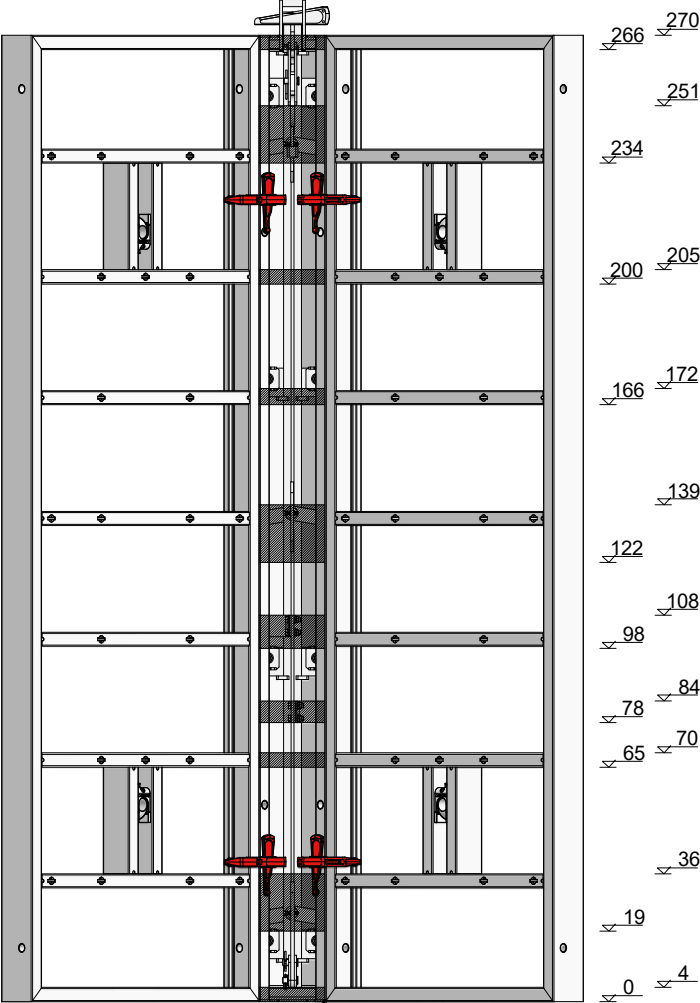

Fig. 49.1 ST stripping corner 270/25

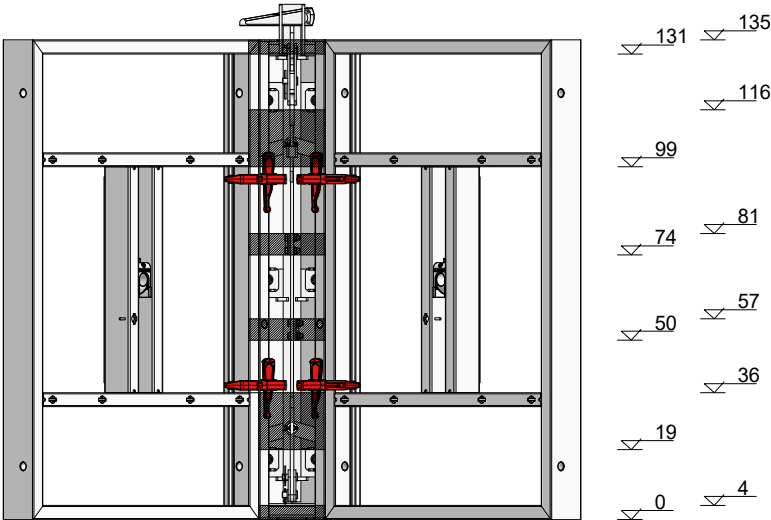
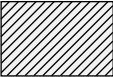

Fig. 49.2 ST stripping corner 135/25

Description	Ref. No.
Stripping corner	
StarTec SC 270/25.....	21-262-10
StarTec SC 135/25.....	21-262-30



No assembly locks possible in grey shaded areas!

Wall Formwork

Stripping corner

Set-up and handling

1. Insert the wedge integrated into the stripping corner into the connecting device (Fig. 50.6 C).
2. Connect stripping corners and formwork panels (see pages ST-XT-48 and -49).
3. Remove the wedges after pouring and prior to stripping.
4. Activate the stripping corner with a crowbar. The bell-crank lever is pushed upwards using the crowbar. The crowbar can be applied at the bottom at position A (Fig. 50.3 A) or in the middle at position B (Fig. 50.4 B). This breaks the bond between the formwork facing and the concrete without much effort.

Pages ST-XT-51 and -52 describe how to activate the stripping corner with the stripping support.

5. Attach the stripping corners with crane slings to the crane gear. Make sure the entire formwork is completely removed from the poured walls before lifting it by crane.
6. The entire formwork is moved in one single lift and detached from the crane when it is in its new position.
7. The stripping corner can be reset for the next pour by positioning the crowbar at position C (Fig. 50.5 C) and pushing the bell-crank lever down.
8. Reinsert the wedge into the connecting device (Fig. 50.6 C).
9. A few hammer blows to the wedge will move the lateral parts of the stripping corner outwards and keep them in the pouring

position.

Note
Returning the stripping corner to its original position by hitting the bell-crank lever with a hammer can result in damage and is not permitted.

Height extension
Two stripping corners can be connected to each other easily by joining their bell-crank levers. The bolt must be secured with a cotter pin through the crane eye (Fig. 50.1 D).

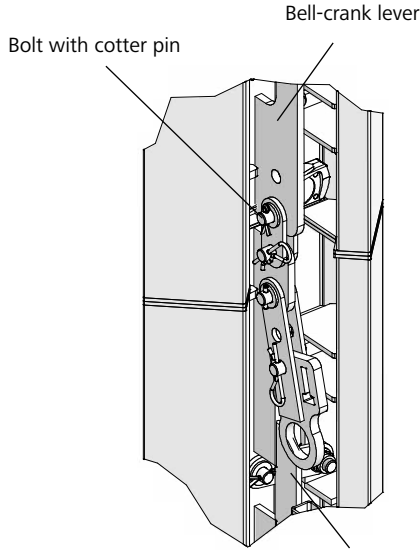

Fig 50.1 D

Bell-crank lever

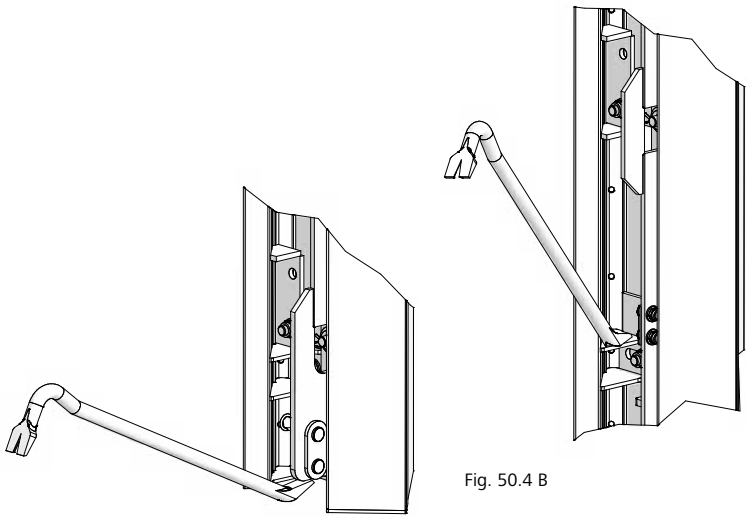

Fig. 50.3 A

Fig. 50.4 B

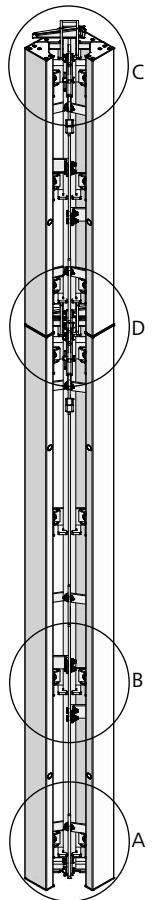

Fig. 50.2

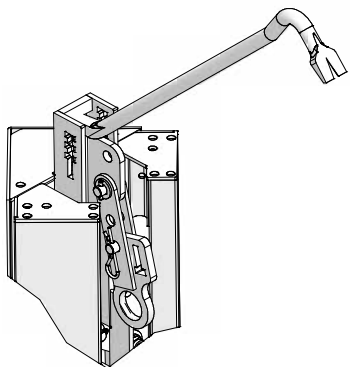

Fig. 50.5 C

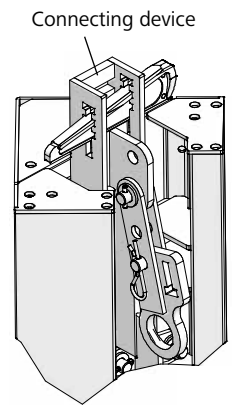

Fig. 50.6 C Pouring position

Description	Ref. No.
Stripping corner	
StarTec SC 330/25.....	21-262-05
StarTec SC 270/25.....	21-262-10
StarTec SC 135/25.....	21-262-30

Stripping corner

Stripping support

The stripping support (Fig. 51.1) is used to easily activate the stripping corner from above

with a power screwdriver, a ratchet spanner or a spanner. Tools with width across flats of 27, 30 or 36 mm are to be used.

Stripping corner tool

The stripping corner tool (Fig. 51.2) also enables the stripping corner to be screwed back to its original position with a power screwdriver, a ratchet spanner or a spanner. Tools with width across flats of 36 mm are to be used.

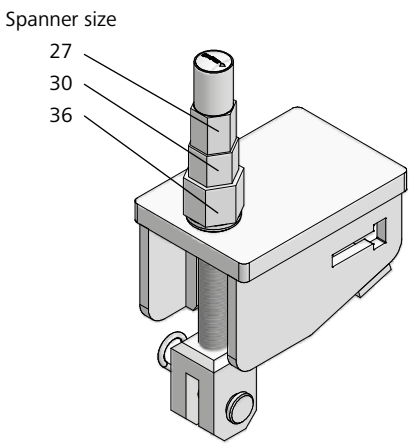

Fig. 51.1

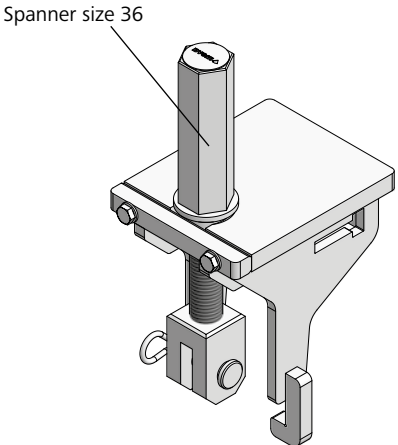

Fig. 51.2

Assembly

1. Place the stripping support onto the connecting device at the top of the stripping corner. Make sure the suspension is inclined downwards (Fig. 51.3).
2. Connect the stripping support to the stripping corner with the head bolt 16/40 and cotter pin 4 that are both integrated into the tensioning screw of the stripping support (Fig. 51.3).
3. Lock the stripping support to the stripping corner by driving the stripping corner's wedge with a few hammer blows into the opening of the stripping support (Fig. 51.3).

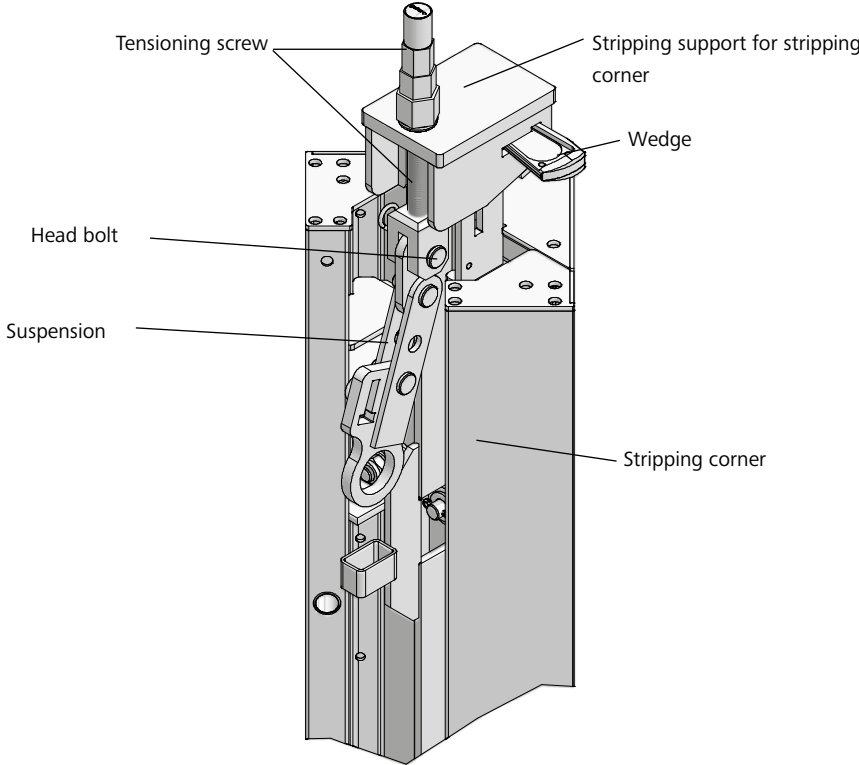

Fig. 51.3

Description	Ref. No.
Stripping support.....	79-306-30
Stripping corner tool.....	29-306-32
Spanner	
size 27.....	29-800-10
size 36.....	29-800-15

Stripping corner

Working principle of the stripping support / stripping corner tool

The stripping support has three hexagonal nuts that are operated with tools with width across flats of 27, 30 and 36 mm.

The stripping corner tool has a hexagonal nut with widths across flats of 36 mm.

Turning the hexagonal nut on the tensioning screw with a power screwdriver (Fig. 52.1), a ratchet spanner (Fig. 52.2) or a spanner moves the bell-crank lever upwards (Fig. 52.5).

This activates the stripping corner and separates the shaft formwork from the poured walls (Fig. 52.4).

When the shaft formwork has been relocated, the stripping corners can be screwed back into their original position using the stripping corner tool (Fig. 52.6).

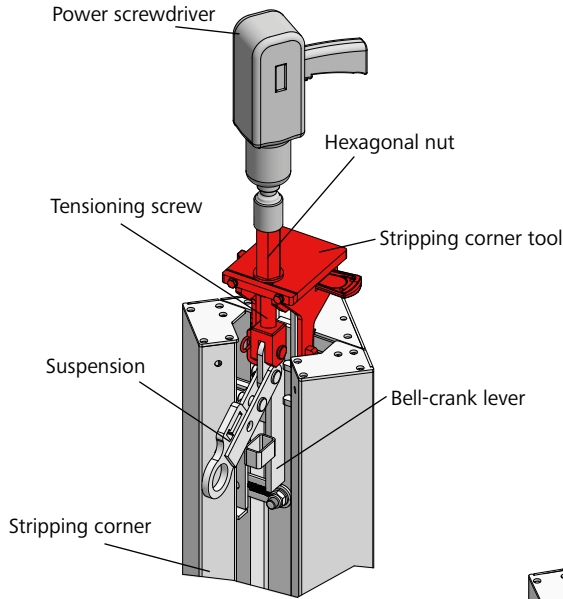

Fig. 52.1

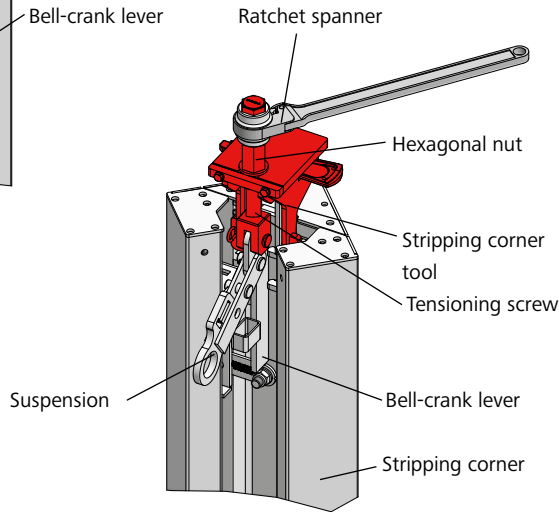

Fig. 52.2

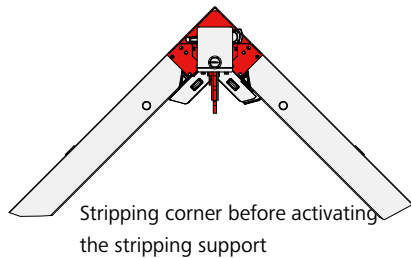

Fig. 52.3

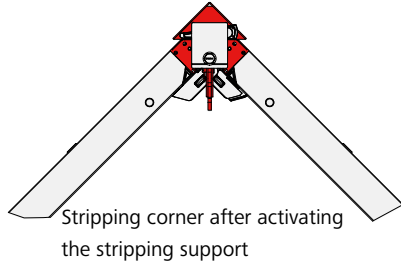

Fig. 52.4

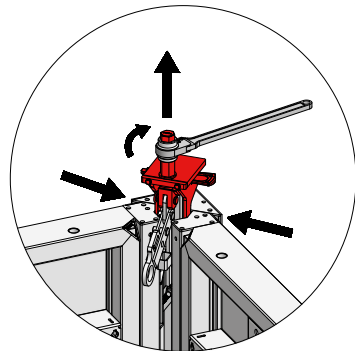

Fig. 52.5

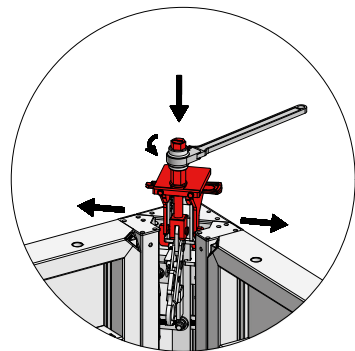

Fig. 52.6

Description	Ref. No.
Stripping support.....	79-306-30
Stripping corner tool.....	29-306-32
Spanner	
size 27.....	29-800-10
size 36.....	29-800-15

Stripping corner

The ST stripping corner can also be used as a stripping aid. In this case, the stripping corner is used to reduce the tension between the panels so that they can easily be removed from the poured wall between the corners.

Steps

1. Remove the AS assembly locks connecting the stripping corners to the panels (Fig. 53.1).
2. Activate the ST stripping corner (Fig. 53.2 and pages ST-XT-50 to -52).
3. Lift the ST stripping corners out of their position, then strip the panels (Fig. 53.3).

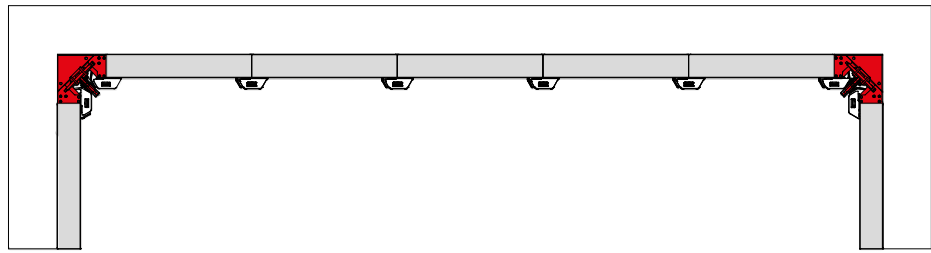

Fig. 53.1

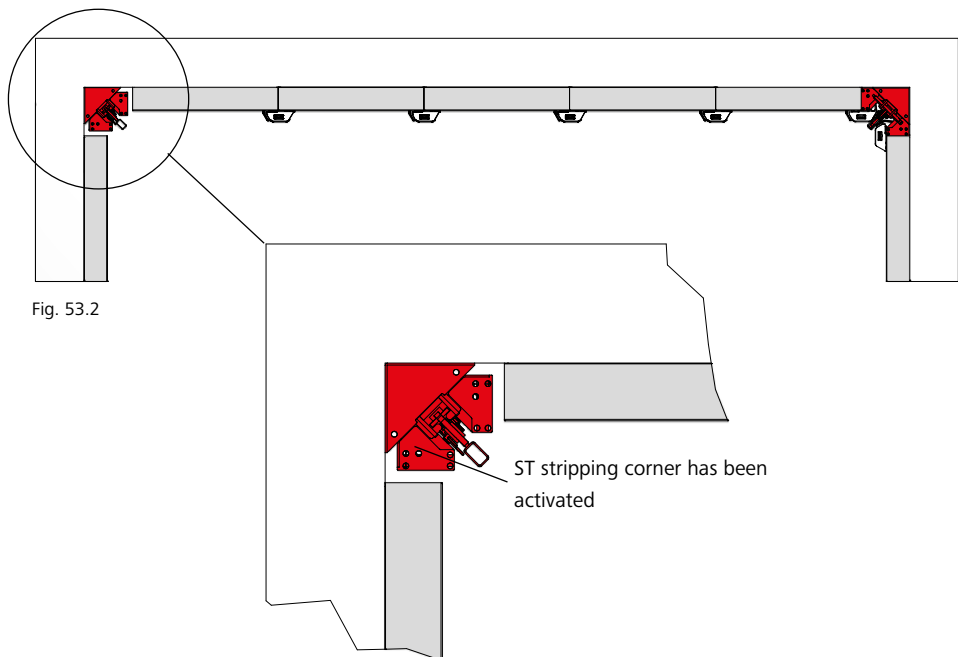

Fig. 53.2

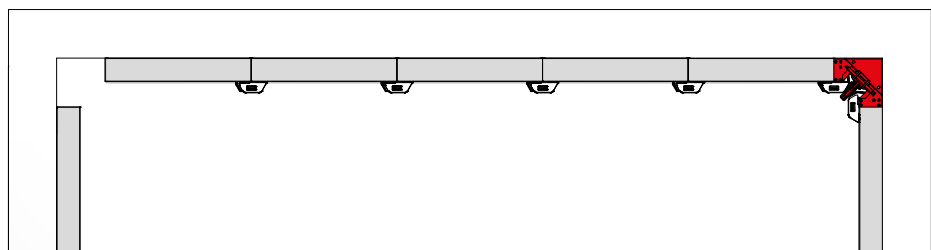

Fig. 53.3

Wall Formwork

Length compensation

Gaps up to 14 cm can be filled on-site using timber fillers and Uni-assembly locks 22, while for gaps up to 20 cm timber fillers and Uni-assembly locks 28 are used. The compensation areas are reinforced with alignment rails, which must always be attached to the panels' multi-function profiles (Fig. 54.1).

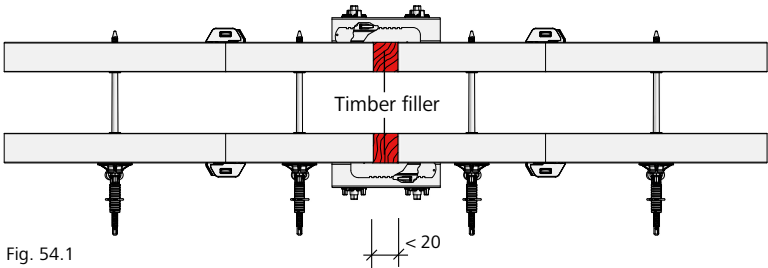

Fig. 54.1

AS/ST timber profiles are used for gaps exceeding 14 cm (Figures 54.2 and 54.3). A facing is cut to size and attached to the timber profiles. For stabilisation, alignment rails with flange nuts are to be attached to the multi-function profile (Fig. 54.2) or to the tie hole (for two-sided tying). The minimum number of alignment rails depends on the number of tie holes / panel height. Refer to Table 3 on page 55 for the maximum filler dimensions.

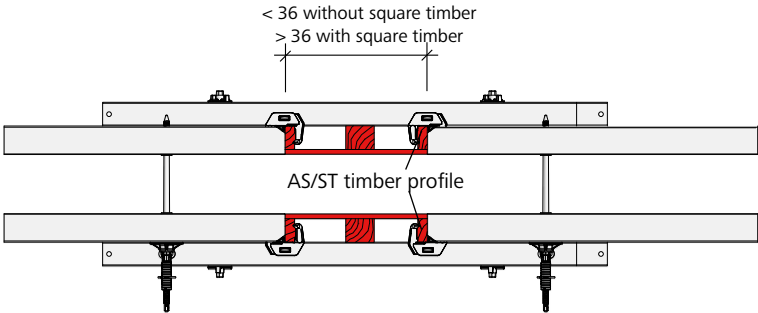

Fig. 54.2

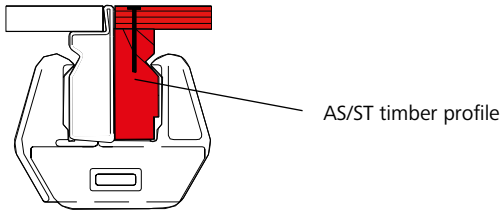

Fig. 54.3

For problem areas, job-built formwork is attached to the panels using AS/ST timber profiles and AS assembly locks (Figures 54.3 and 54.4).

Gaps can be closed using one or two AS/ST aluminium fillers. In the case of two adjacent fillers, the second filler is rotated through 180°. The fillers have tie holes.

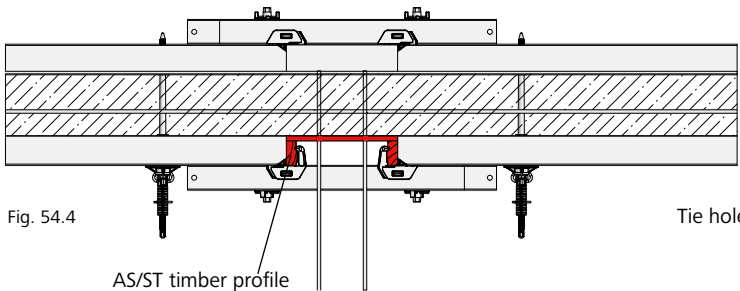

Fig. 54.4

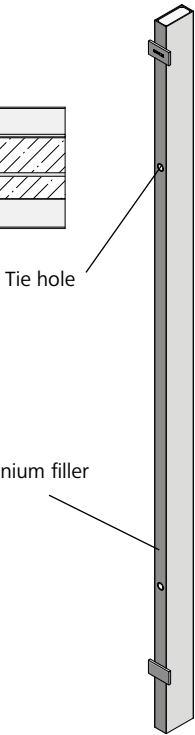

Fig. 54.5

Description	Ref. No.
AS assembly lock	29-205-00
Uni-assembly lock 22	29-400-85
Uni-assembly lock 28	29-400-90
AS/ST timber profile	
330/21	29-200-07
270/21	29-200-03
135/21	29-200-05
SA 270/27	29-200-04
SA 135/27	29-200-06
AS/ST aluminium filler 330/4..	21-270-54
AS/ST aluminium filler 330/5..	21-270-58
AS/ST aluminium filler 330/6..	21-270-56
AS/ST aluminium filler 330/8..	21-270-57
AS/ST aluminium filler 270/4..	21-270-59
AS/ST aluminium filler 270/5..	21-270-60
AS/ST aluminium filler 270/6..	21-270-61
AS/ST aluminium filler 270/8..	21-270-62
AS/ST aluminium filler 135/4..	21-270-64
AS/ST aluminium filler 135/5..	21-270-65
AS/ST aluminium filler 135/6..	21-270-66
AS/ST aluminium filler 135/8..	21-270-67

Length compensation – Filler widths

The maximum filler width x for the bracing at tie hole level (Figures 55.1 and 55.2) and the bracing at the multi-function profile level is determined by the permissible fresh-concrete pressure and the type of alignment rail used (Table 55.3).

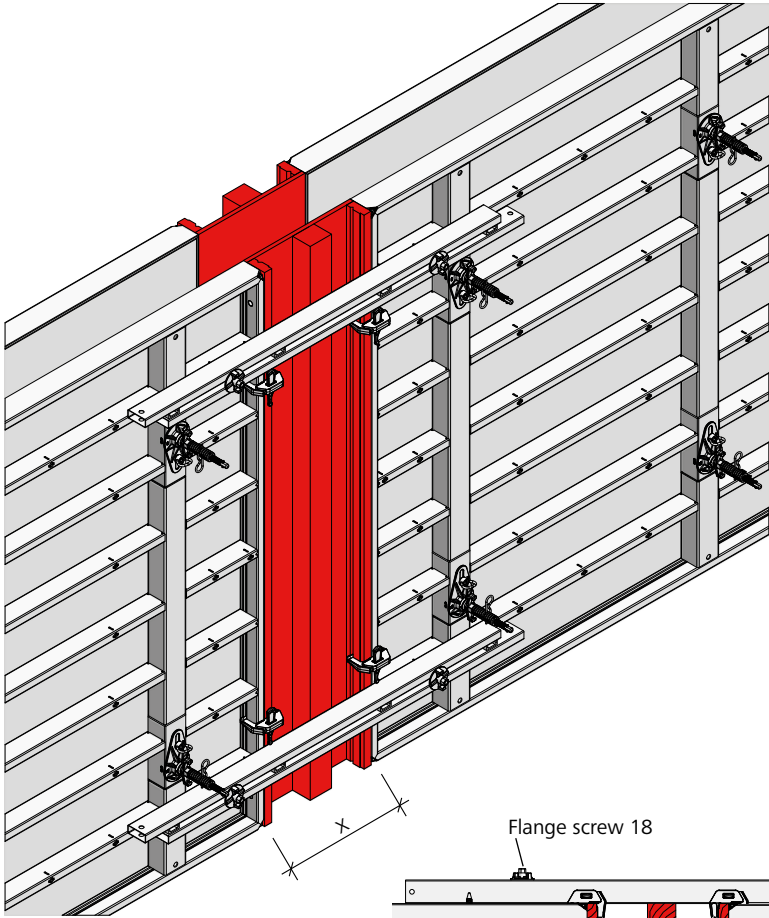

Fig. 55.1

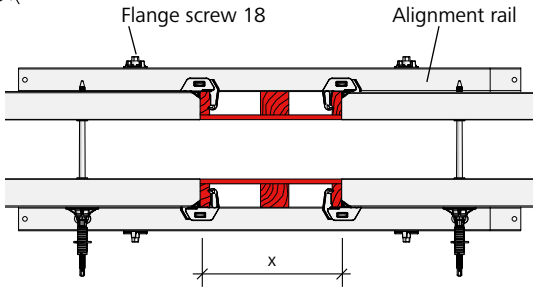

Fig. 55.2

If the fresh-concrete pressure is $p_{\text{max}} = 60 \text{ kN/m}^2$ and if lines 5 and 6 of DIN 18202 are observed (see page ST-XT-27), the following filler widths (cm) can be bridged:

Alignment rail	Filler width x at tie hole level	Filler width x on multi-function profile
AS-RS 50	35	25
AS-RS 125	70	70
AS-RS 200	80	80
M-RS 180	80	100
M-RS 250	80	110
M-RS 450	125	175

Table 55.3

Description	Ref. No.
AS alignment rail 200	29-201-80
AS alignment rail 125	29-201-75
AS alignment rail 50	29-201-73
M alignment rail 450 reinforced	29-402-38
M alignment rail 450	29-402-40
M alignment rail 250	29-402-50
M alignment rail 180	29-400-92
Flange screw 18.....	29-401-10

Wall Formwork

T wall connection

A T wall connection can be formed using two ST inside corners (IC) (Fig. 56.1).

Depending on the wall thickness, timber fillers with the corresponding thickness are used on the long wall opposite the inside corner (Figures 56.1 and 56.2 and Table 56.3).

30 cm wide StarTec XT panels are to be installed next to the inside corner (Figures 56.1 and 56.2).

For the load capacity and the maximum permissible compensation widths of the alignment rails refer to Table 3 on page ST-XT-55.

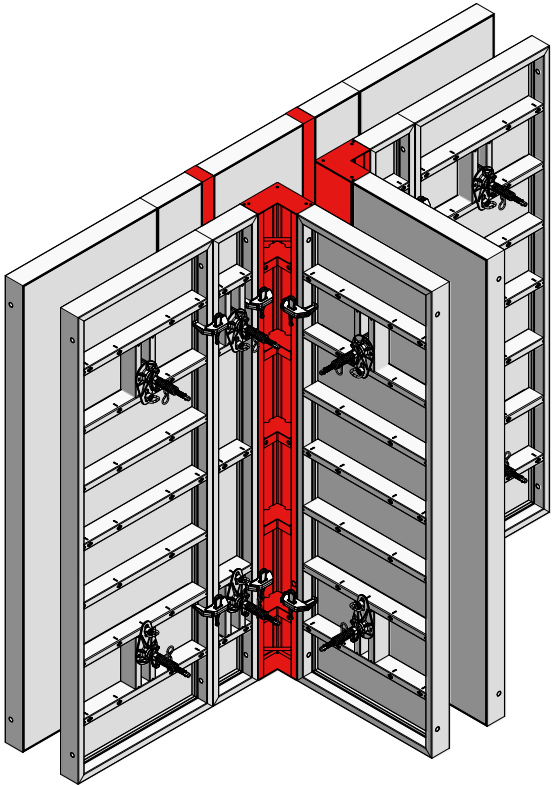

Fig. 56.1

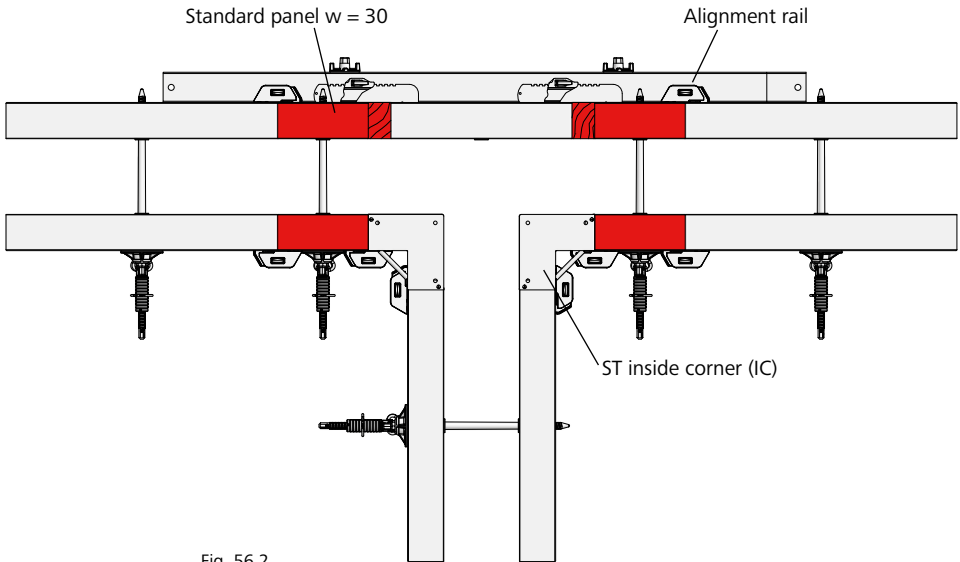

Fig. 56.2

Description	Ref. No.
AS assembly lock	29-205-00
Uni-assembly lock 22	29-400-85
Uni-assembly lock 28	29-400-90
AS alignment rail 200	29-201-80
AS alignment rail 125	29-201-75
AS alignment rail 50	29-201-73
M alignment rail 450	29-402-40
M alignment rail 250	29-402-50
M alignment rail 180	29-400-92
M cross stiffener 44	29-401-02
Flange screw 18	29-401-10
StarTec inside corner	
StarTec AL IC 330/25	21-251-00
StarTec AL IC 270/25	21-251-05
StarTec AL IC 135/25	21-251-35

Wall thickness (in cm)	Panel (opposite the IC)	Timber filler
20	ST XT 60	10 (2 x 5)
25	ST 75	–
25	ST XT 60	15 (2 x 7.5)
30	ST XT 60	20 (2 x 10)

Fig. 56.3

T wall connection – Different wall thicknesses

A T wall connection with varying wall thicknesses can be created using two ST inside corners and timber fillers or timber profiles with facings cut to size (Figures 57.1 and 57.2).

To guarantee the load capacity, the maximum permissible compensation widths of the alignment rails must be observed (see Table 3 on page ST-XT-55).

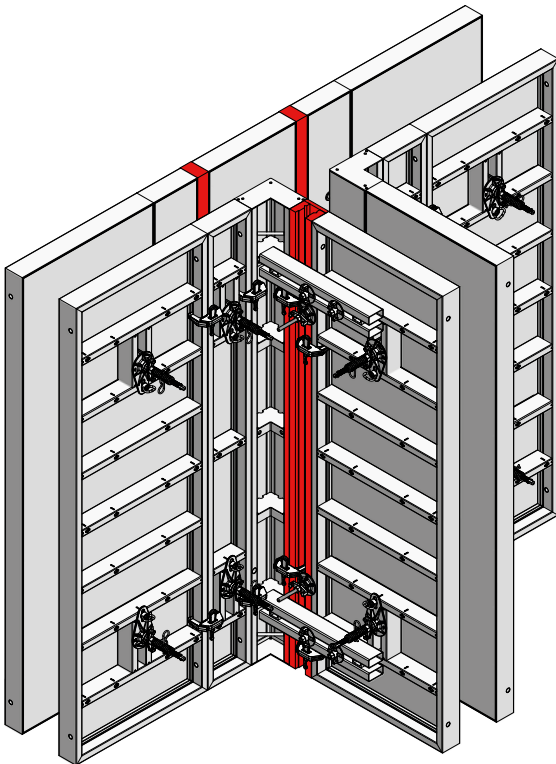

Fig. 57.1

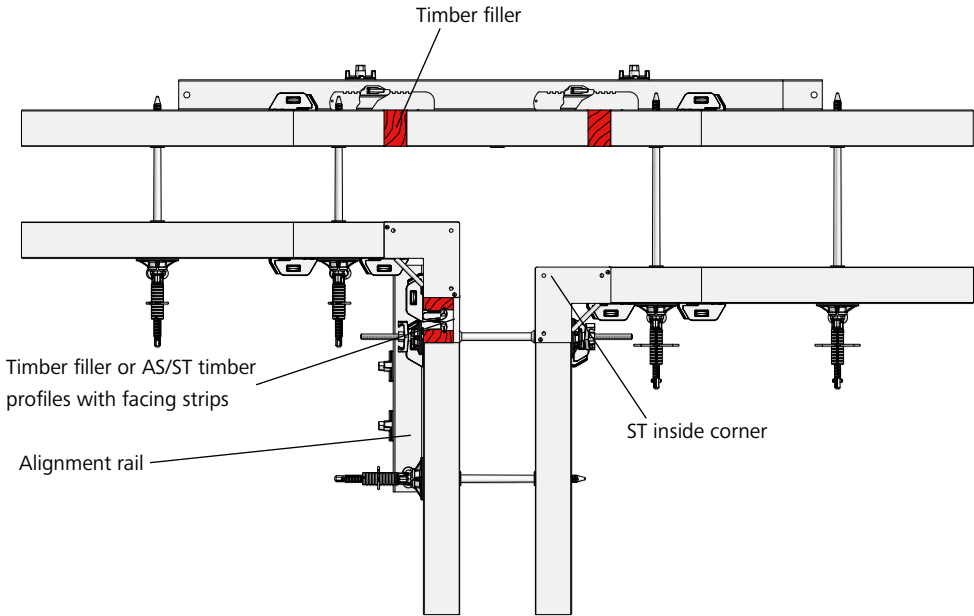

Fig. 57.2

Description	Ref. No.
AS assembly lock	29-205-00
Uni-assembly lock 22	29-400-85
Uni-assembly lock 28	29-400-90
AS alignment rail 200	29-201-80
AS alignment rail 125	29-201-75
AS alignment rail 50	29-201-73
M alignment rail 450 reinforced	29-402-38
M alignment rail 450	29-402-40
M alignment rail 250	29-402-50
M alignment rail 180	29-400-92
Uni-assembly lock 22	29-400-85
Uni-assembly lock 28	29-400-90
M cross stiffener 44	29-401-02
Flange screw 18	29-401-10
AS/ST timber profile 330/21	29-200-07
AS/ST timber profile 270/21	29-200-03
AS/ST timber profile 135/21	29-200-05

Wall Formwork

Connection to existing walls

The panels can be connected to existing walls without problem through the internal tie holes of all StarTec XT panel widths (Figures 58.1 and 58.2).

Figures 58.3 and 58.4 show various options for connecting formwork to an existing wall. Depending on the wall layout and conditions on the construction site, the most suitable solution may vary from case to case.

Always make sure the formwork is firmly pressed up against the existing wall and attached to it without gaps in order to avoid leakage of the fresh concrete and a patchy concrete surface (Fig. 58.4).

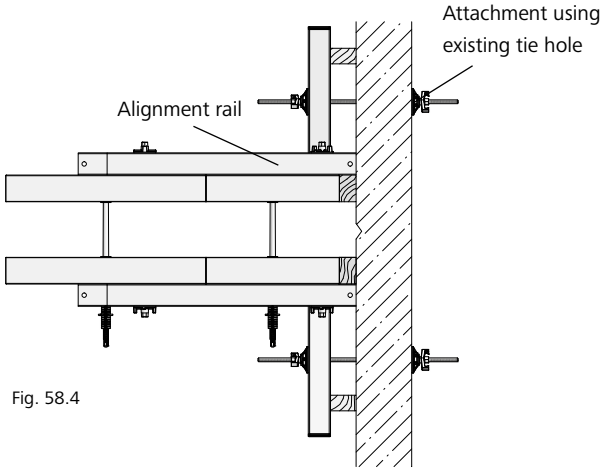
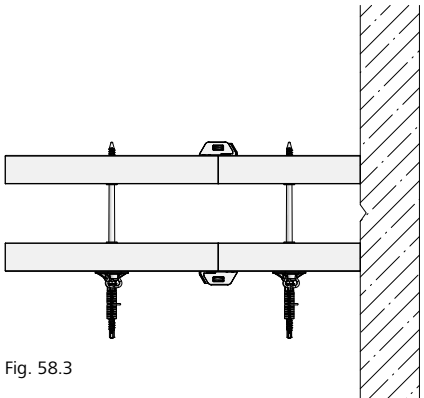
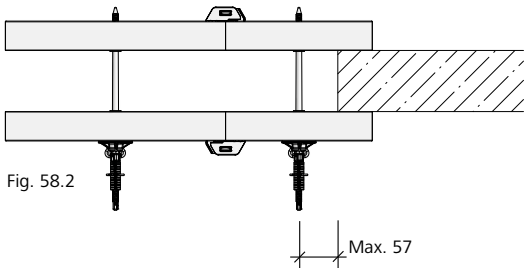
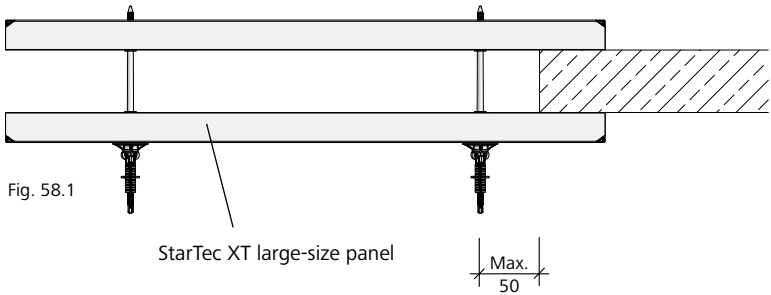

Wall Formwork

Wall offset

One-sided wall offsets of up to 10 cm are formed by moving back the corresponding standard panel (Fig. 59.1).

For offsets from 13 to 23 cm ST inside corners should be used (Fig. 59.2).

The panels are connected using job-built wooden blockings with the Uni-assembly lock 22 (Figures 59.3 and 59.4).

All types of wall offset require alignment rails for reinforcement (Figures 59.1 and 59.2).

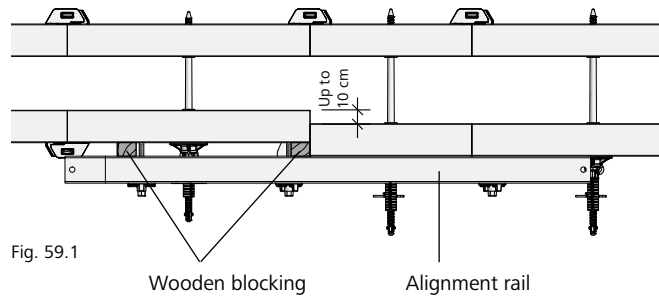

Fig. 59.1

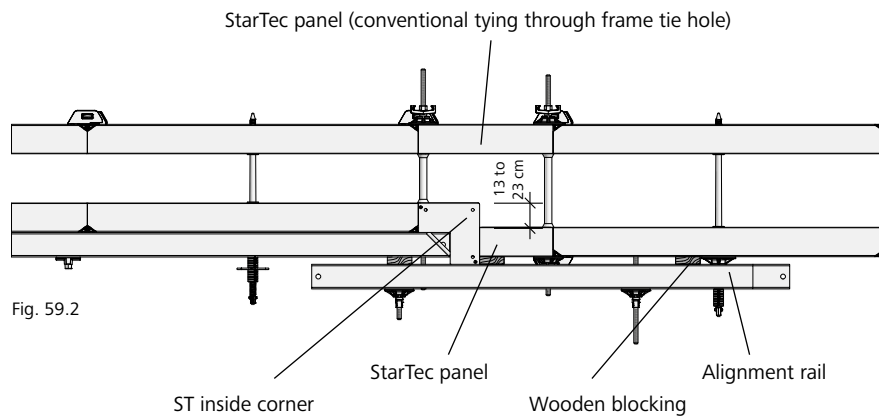

Fig. 59.2

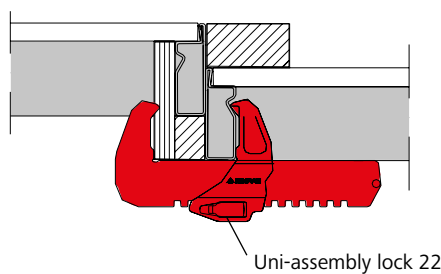

Fig. 59.3

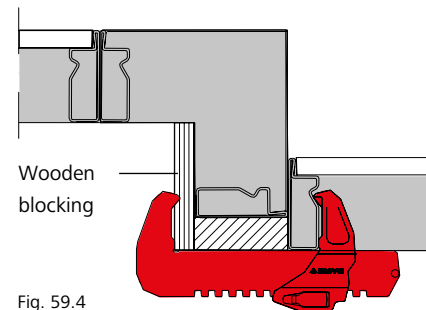

Fig. 59.4

Description	Ref. No.
Uni-assembly lock 22	29-400-85
Uni-assembly lock 28	29-400-90

Wall Formwork

Stop ends

With outside corners and standard panels

Stop ends can also be formed using AS/ST outside corners and standard panels (Figures 60.1, 60.3 and 60.4).

- Additional alignment rails are required above a pouring height of 270 cm and a distance of 50 cm to the first tie hole.
- When using StarTec XT panels with the width 135 cm, additional alignment rails are required.
- One alignment rail is required for reinforcement at each tie hole level. The reinforcement of each tie hole level consists of one alignment rail with two flange screws 18 attached to the panel's multi-function nuts.

For the number of assembly locks required at the AS/ST outside corner and at the first panel joint refer to Table 60.2.

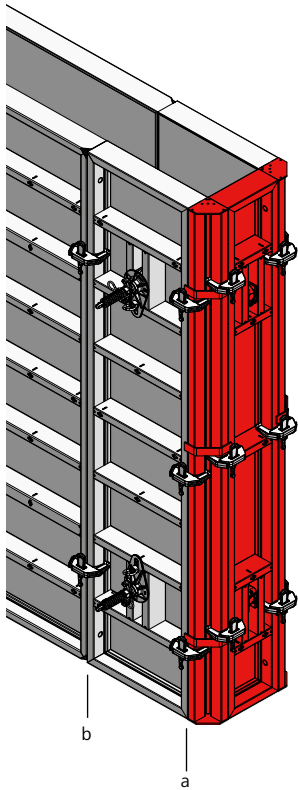

Fig. 60.1

Pouring height	Number of AS assembly locks	
	Corner (a)	At panel joint (b)
h = 0.90 m	2	2
h = 1.35 m	2	2
h = 2.70 m	3	2
h = 3.30 m	4	3
h = 4.05 m	5	4
h = 4.65 m	6	5
h = 5.40 m	6	5

Table 60.2

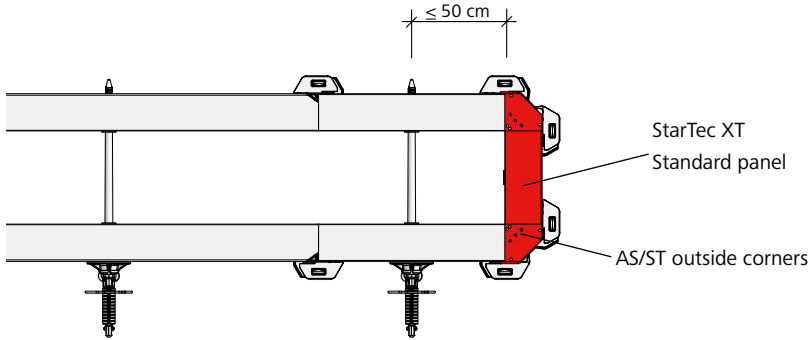

Fig. 60.3

- Additional alignment rails are required:
- Above a pouring height of 270 cm and a distance of 50 cm to the first tie hole.
 - When using panels with a width of 135 cm.

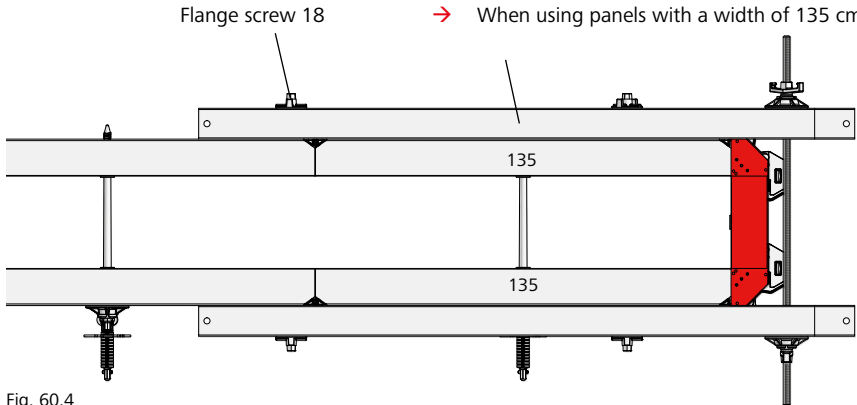

Fig. 60.4

Description	Ref. No.
AS assembly lock	29-205-00

Wall Formwork

Stop ends

Stop ends can be formed either with a stop end bracket or a stop end fixture and alignment rail.

Stop end bracket

For wall thicknesses up to 40 cm (40/60) or 30 cm (23/40). The following is used at each tie hole level:

- One stop end bracket
- It is attached at the height of the tie holes (Fig. 61.1).

Stop end fixture and alignment rail

The following is used at each tie hole level:

- Two stop end fixtures 23/40
 - Two flange nuts 100
 - One alignment rail
- Outside of the panel the following is required at each tie hole level:
- One tie rod DW 15
 - Two Uni-tie claws
 - Two flange nuts 100

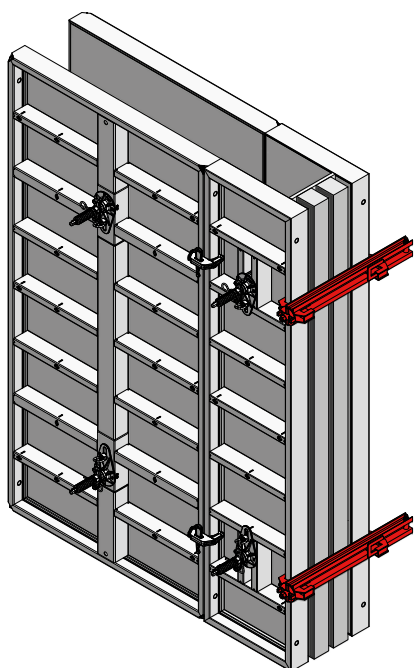

Fig. 61.1

Up to WT = 40 cm with stop end bracket 40/60
Up to WT = 30 cm with stop end bracket 23/40

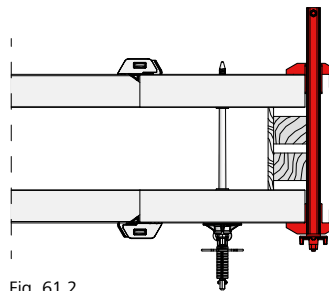

Fig. 61.2

Attention

Never use DW tie rods for stop ends if these are subject to shear stress.

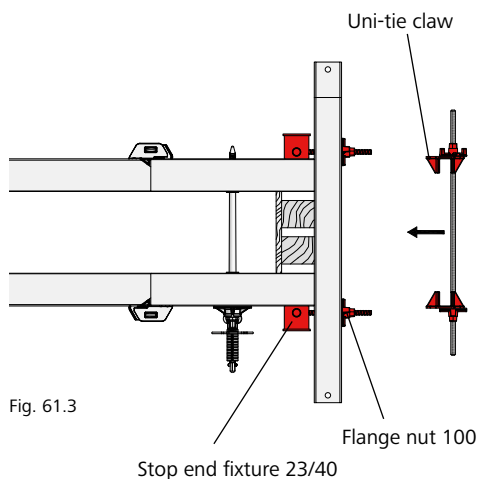

Fig. 61.3

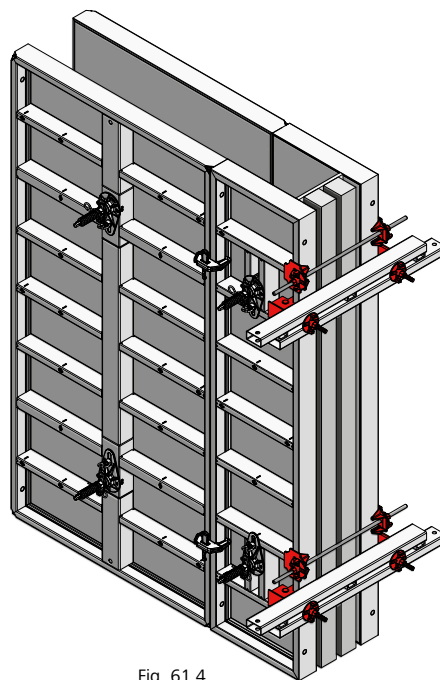

Fig. 61.4

Description	Ref. No.
Stop end bracket 40/60	29-105-50
Stop end bracket 23/40	29-105-45
Uni-tie claw	29-901-41
Stop end fixture 23/40 yellow	79-402-85
Flange nut 100	29-900-20
AS alignment rail 50	29-201-73
AS alignment rail 125	29-201-75
Tie rod DW 15/90	29-900-80

Wall Formwork

Pilasters

Standard pilasters are easily formed with ST inside corners, standard panels and, where necessary, wooden blockings. Stop end brackets and alignment rails must be attached for reinforcement (Figures 62.1 to 62.3). Depending on the wall thickness required, timber fillers and alignment rails may also be required on the wall opposite the pilaster (Fig. 62.2).

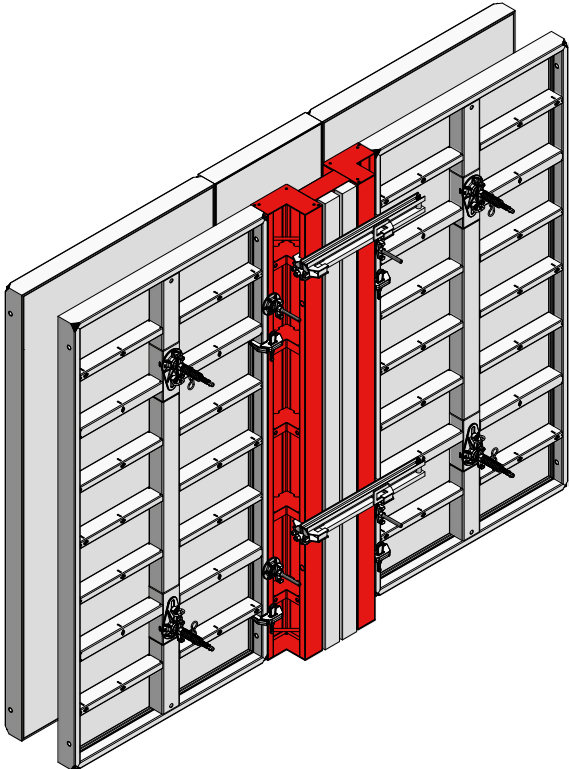

Fig. 62.1

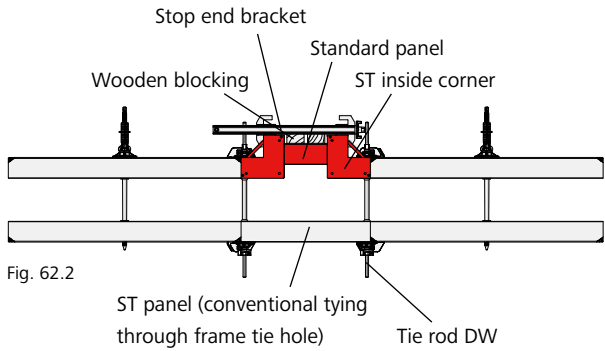

Fig. 62.2

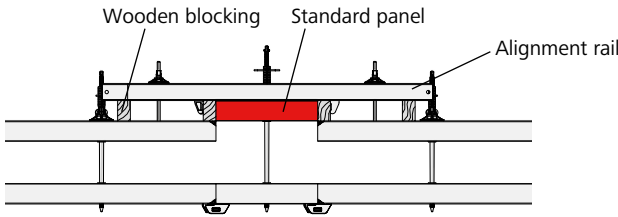

Fig. 62.3

Description	Ref. No.
Stop end bracket 40/60	29-105-50
Stop end bracket 23/40	29-105-45

Wall Formwork

Differences in height

The assembly lock can be attached at any position on the panel joint between the cross stiffeners (Fig. 63.1). The formwork's grid-free design does not require additional accessories for panel connection. Vertical, horizontal and inclined panels can all be safely and firmly connected with AS assembly locks, even with differences in height.

A job-built length compensation is produced using timber profiles and an alkus facing cut to the size required or a wooden board. If required, use square timbers for reinforcing. A compensation larger than 36 cm requires a centred square timber to support the facing.

Square timbers and the facing are simply connected with AS assembly locks. Pay special attention when using wood fillers (see page ST-XT-55). It may be necessary to use alignment rails and/or wooden blockings.

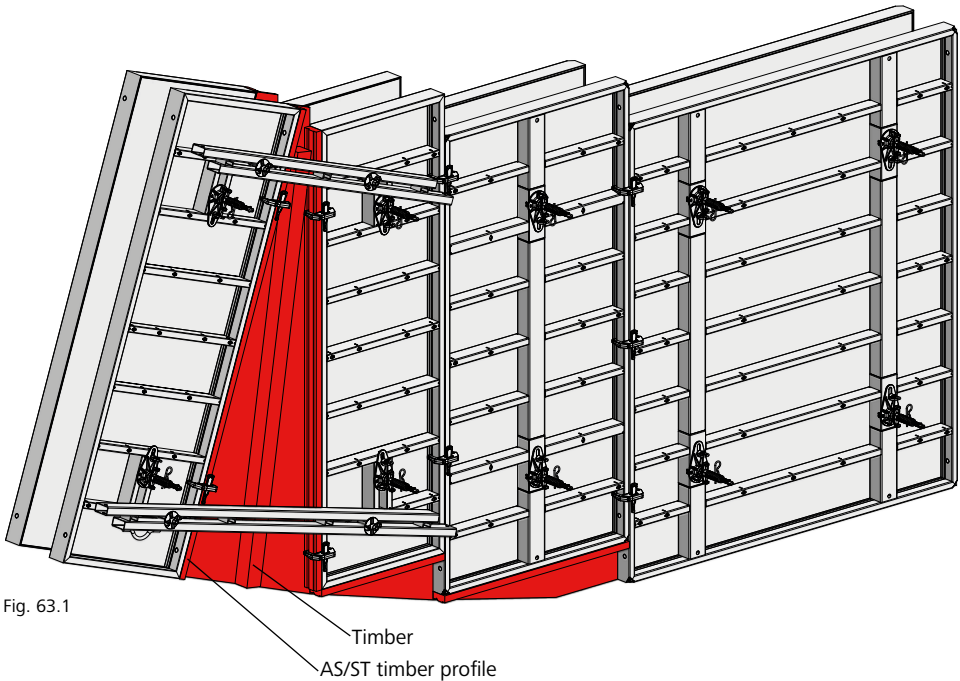

Fig. 63.1

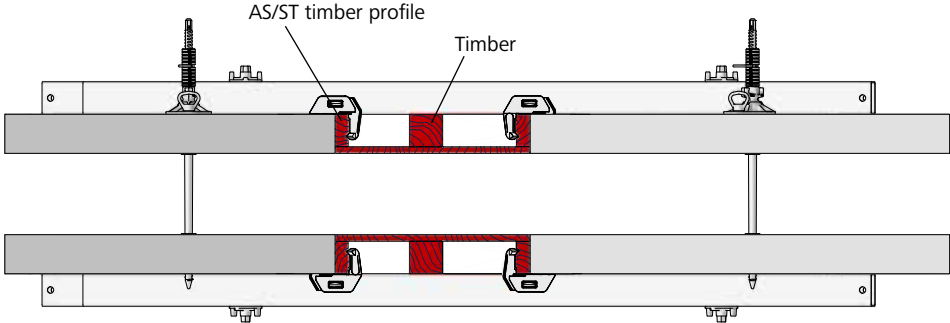

Fig. 63.2

Description	Ref. No.
Uni-assembly lock 22.....	29-400-85
Uni-assembly lock 28.....	29-400-90
AS/ST timber profile 330/21....	29-200-07
AS/ST timber profile 270/21....	29-200-03
AS/ST timber profile 135/21....	29-200-05

Wall Formwork

Horizontal panels

StarTec XT allows a lot of forming problems to be easily solved. These include foundations, kickers and formwork tasks involving integrated joint tape.

The central tie hole allows the panel to be used horizontally without problem (Figures 64.1 and 64.3). To provide stability in the vicinity of the top tie hole, a spacer (Fig. 64.6) or a wooden blocking may be required. The spacer is available for wall thicknesses 20, 24, 25 and 30 cm.

To prevent a tie hole remaining in the component, foundation tape and tensioners can be used under the formwork panel (Figures 64.2 and 64.4). The tensioner is attached to the formwork using a wedge. The maximum tensioner spacing is to be observed (Table 64.5).

The Uni-tie claw can be used as the top tie connection. The following is required for each tie hole:

Two Uni-tie claws, one tie rod DW 15 and two flange nuts 100 (Figures 64.1 to 64.4). We also recommend the use of a plastic tube. It serves as a spacer and protects the tie connection against contamination.

The purpose of the compensation plate 12 (55 x 55) is to compensate for gaps between foundation formwork with a maximum foundation formwork height of 55 cm (Fig. 64.7). The maximum compensation width is 55 cm.

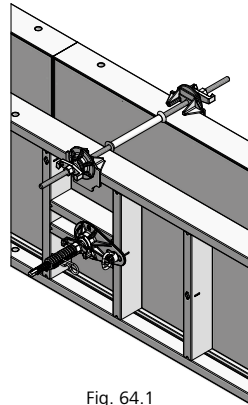

Fig. 64.1

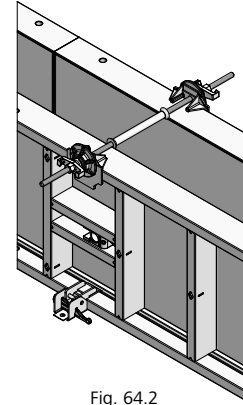

Fig. 64.2

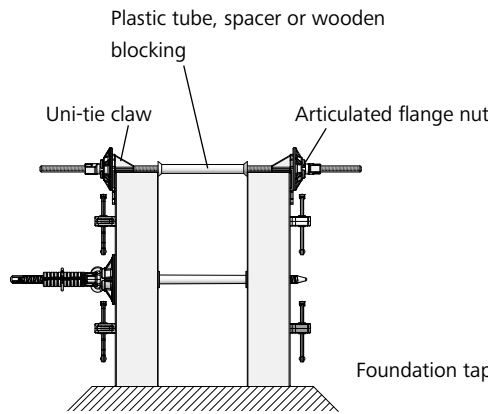

Fig. 64.3

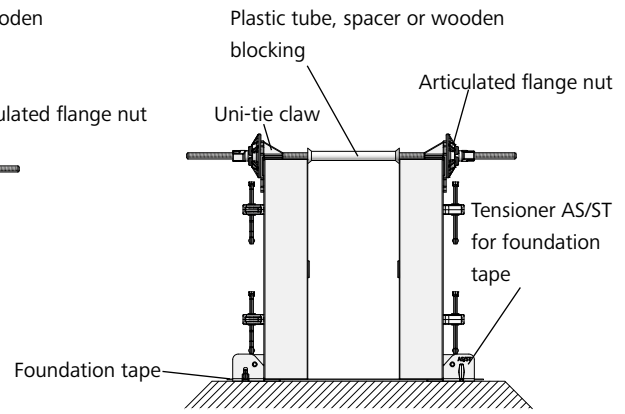

Fig. 64.4

Maximum tensioner spacing	
Pouring height 75 cm	185 cm
Pouring height 100 cm	120 cm
Pouring height 125 cm	70 cm

Table 64.5

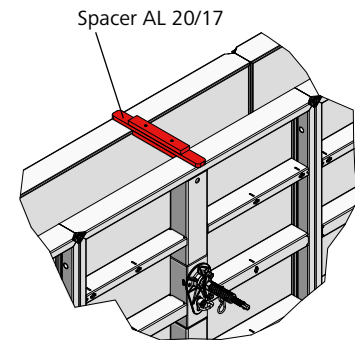

Fig. 64.6

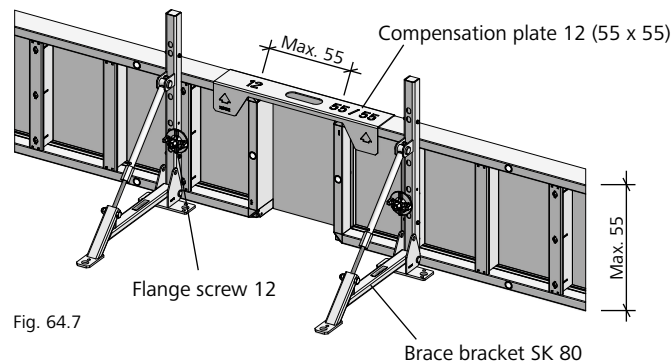

Fig. 64.7

Description	Ref. No.
Push-pull strut	79-105-70
Uni-tie claw	29-901-41
Foundation tape	29-307-50
Tensioner AS/ST for foundation tape	29-307-70
Trolley for foundation tape	29-307-55
Compensation plate 12	29-201-17
Brace bracket 80	29-921-35
Flange screw 12	29-900-70
Spacer 20/24 AL20/17	29-901-52
Spacer 25/30 AL20/17	29-901-62

Height-extending from above or below

All StarTec XT panels can be height-extended vertically or horizontally. The ability to freely combine all panels vertically or horizontally allows for economic width and height extension in increments up to 30 cm (see page ST-XT-11). They must always be connected with the AS assembly lock (see page ST-XT-14). The continuous grooves on the panels allow the assembly locks to be positioned steplessly.

→ Alignment rails are required for height extensions to stabilise the panels (Table 65.3). For heights above 8.10 m please contact our application engineering department. The total weight of the height-extended unit depends on the load capacity of the crane hook (see page ST-XT-67).

→ For a height extension with a panel that is up to 30 cm wide, it is not necessary to install ties in the tie holes of the height-extended panel as long as the scaffolding bracket is attached to the panel below (Fig. 65.2). However, if the scaffolding bracket is attached to the top panel, it is necessary to install ties in the top tie holes. The Uni-tie claw in conjunction with a tie rod and a flange nut 100 can also be used to tie this configuration.

→ The panels 135/240 and 135/330 are particularly suitable when height-extending from below. Two (Fig. 65.4) or three M alignment rails 180 (Fig. 65.5) are attached to the horizontal panel joint, each of which is secured to the multi-function nuts with three flange screws 18.

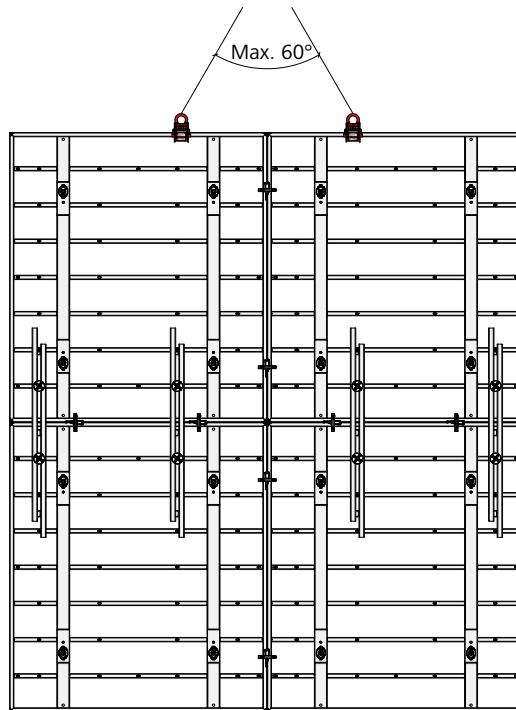

Fig. 65.1

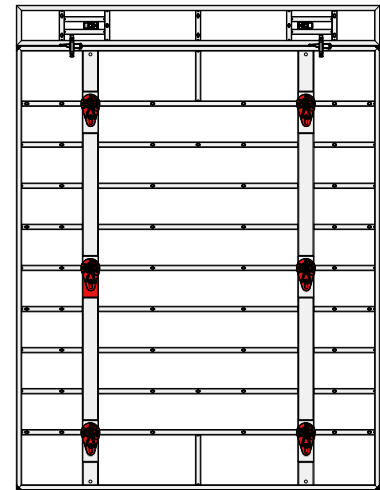

Fig. 65.2

Formwork height	Alignment rail for each horizontal joint for a width of 1.35 m	
	Alignment rail	Quantity
Up to 5.40 m	M 180	1
Up to 8.10 m	M 250	1

Table 65.3

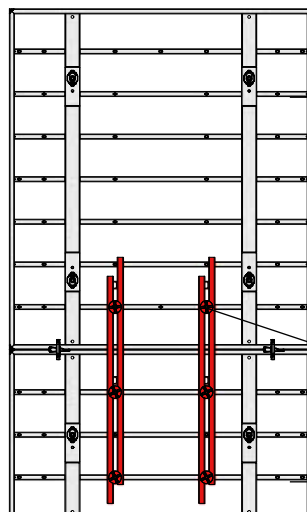

Fig. 65.4

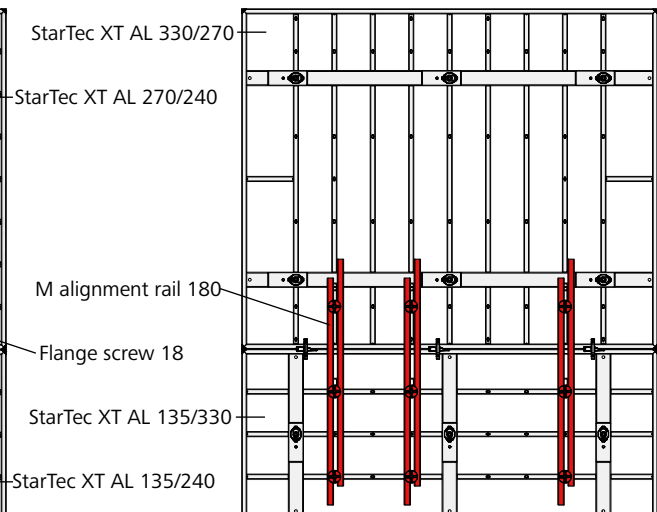

Fig. 65.5

Description	Ref. No.
M alignment rail 180	29-400-92
M alignment rail 250	29-402-50
Flange screw 18.....	29-401-10

Stabilisation of units

For an optimum load distribution, it is sensible to use large-size panels (Fig. 66.1).

If three or more panels with a central tie hole (panel widths of 135 cm or less) are located next to each other, the unit is reinforced by attaching an AS alignment rail 125 to the lowest multi-function profile of the panel joint (Figures 66.2 and 66.3).

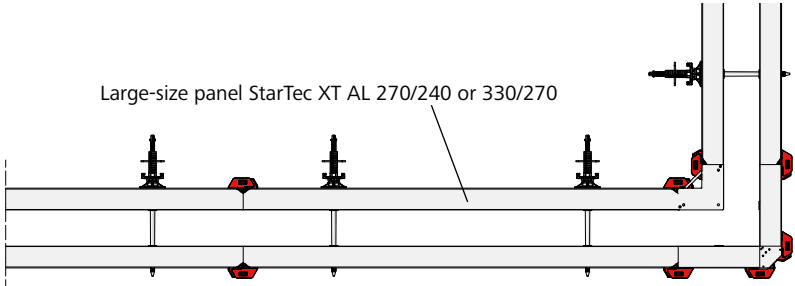

Fig. 66.1

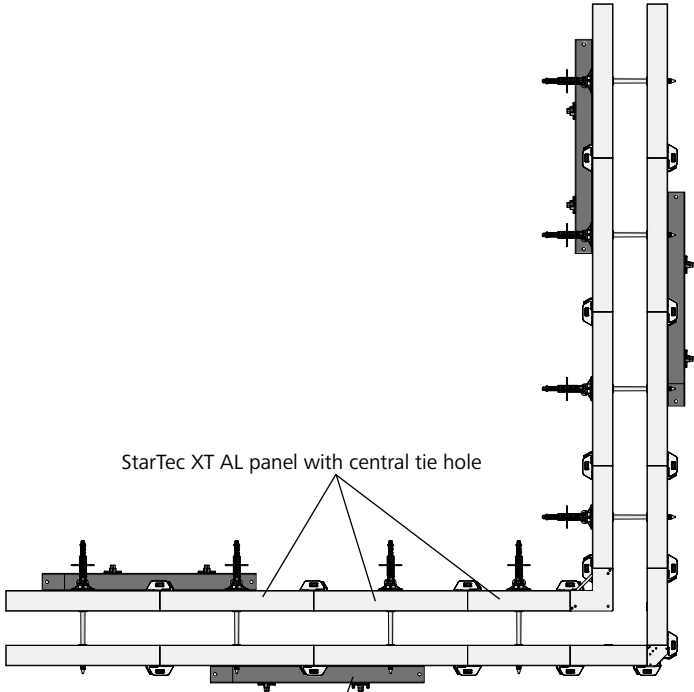

Fig. 66.2

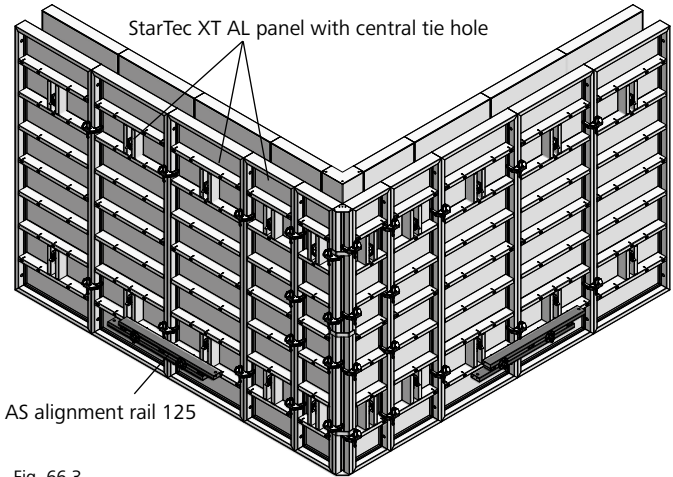

Fig. 66.3

Description	Ref. No.
AS alignment rail 125	29-201-75
Flange screw 18.....	29-401-10

Wall Formwork

Crane ganging

Each transport unit requires two AS crane hooks with a load capacity of 15 kN (1.5 tons) attached symmetrically to the centre of gravity (Figures 67.1 and 67.2)!

The opening angle of the crane slings must not exceed 60°.

When the panels are horizontal, the crane hook must be attached to a cross stiffener to prevent it from slipping (Fig. 67.1).

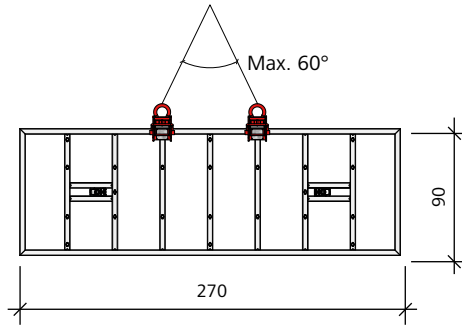

Fig. 67.1

The total weight of the panel unit must not exceed the permissible load capacity of the crane hook (2 x 15 kN = 30 kN or 3 t).

Fig. 67.1

Large panel:
2.70 m x 0.90 m = 2.43 m²
Weight 116 kg

Fig. 67.2

Large panel unit:
2.70 m x 4.80 m = 12.96 m²
Weight 815 kg

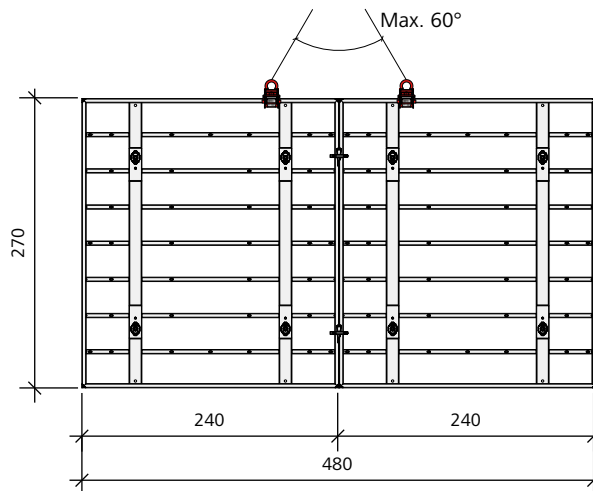

Fig. 67.2

Description	Ref. No.
AS crane hook	29-203-89

Crane ganging

In order to provide the necessary flexural rigidity when lifting and laying down gangs, alignment rails must be mounted to the panels with flange screws (Fig. 68.3).

Fig. 68.1
StarTec panel unit with alkus all-plastic facing. Size: 4.80 x 4.05 m = 19.44 m²
Weight: 1165 kg.

Fig. 68.2
StarTec panel unit with alkus all-plastic facing. Size: 5.40 x 6.60 m = 35.64 m².
Weight including four alignment rails 250 = 2396 kg.

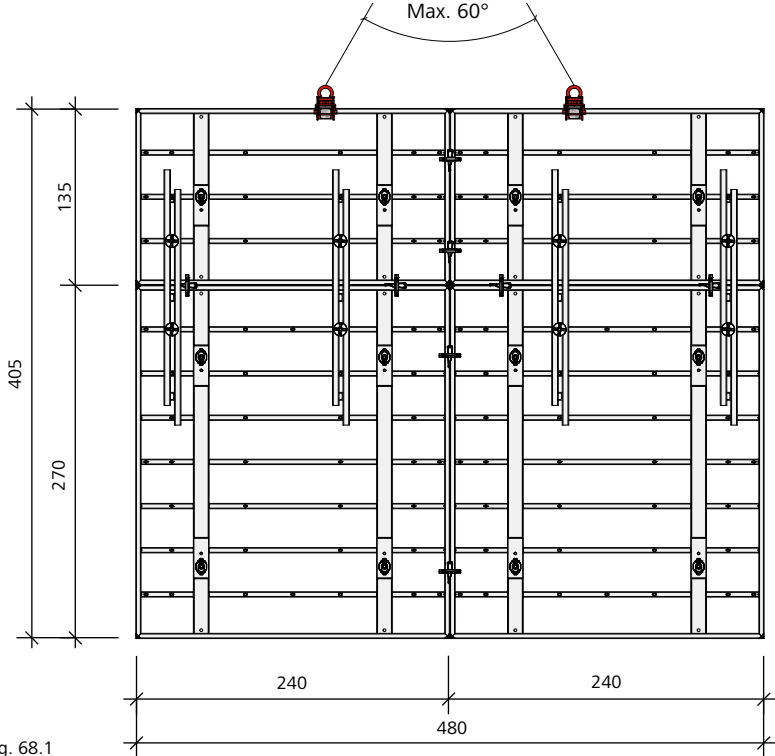

Fig. 68.1

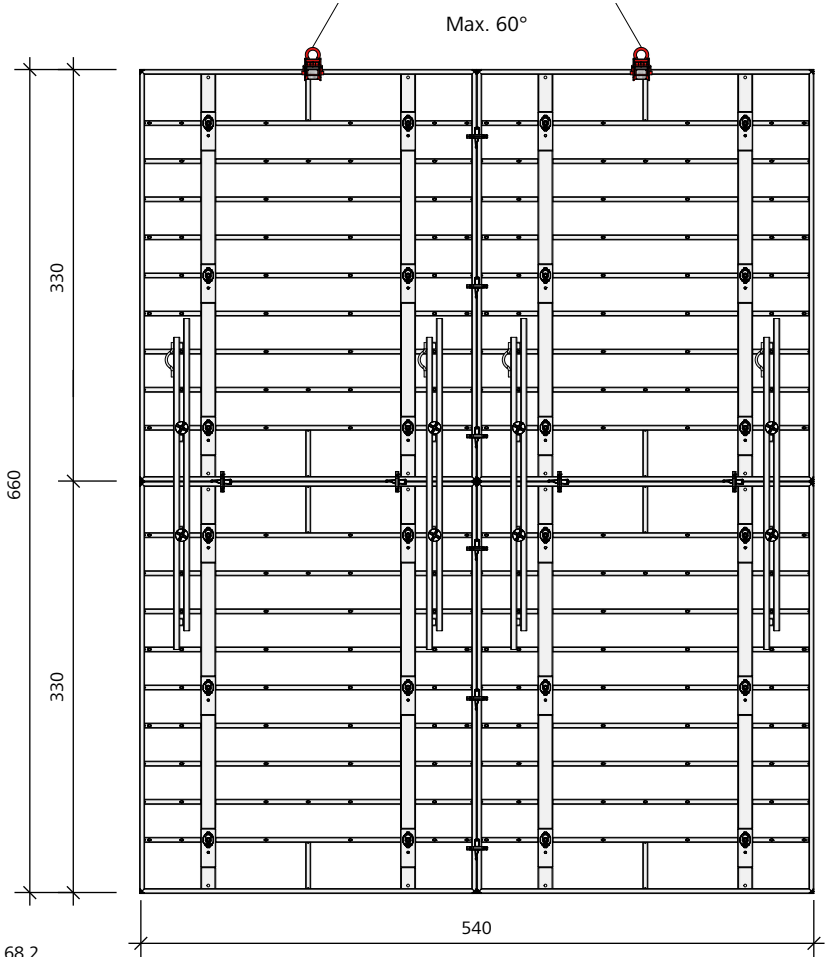

Fig. 68.2

Wall Formwork

Column formwork – With standard panels

Columns with a maximum side length of 50 cm and a maximum pouring height of 405 cm can be formed using standard panels and outside corners.

For the number of assembly locks required refer to Table 69.1.

The higher fresh-concrete pressure resulting from high columns or from longer side lengths means that additional alignment rails are required for reinforcement (Table 69.1). The alignment rails must be attached to the multi-function profiles on all four sides of the panels with two flange screws 18. Always install the alignment rails starting with the lowermost multi-function profile level (Figures 69.6 to 69.8). Also observe DIN 18218 for fresh-concrete pressure and DIN 4235 for compacting concrete with a vibrator.

When pouring foundations, two assembly locks are required for a foundation with a maximum side length of 135 cm and a maximum height of 135 cm.

ST column formwork						
Formwork height h [cm]	Number of alignment rails (from bottom to top)				Number of AS assembly locks	
	Column side length [cm]					
	Up to 50	75	90	135		
135	-	-	-	-	2	
270	-	-	-	-	4	
270 + 135 = 405	-	1	1	1	(5 + 2) = 7	
270 + 270 = 540	1	1	1	1	(5 + 5) = 10	
270 + 270 + 135 = 675	1	2	2	3	(5 + 5 + 2) = 12	
270 + 270 + 270 = 810	2	3	3	4	(5 + 5 + 5) = 15	

Table 69.1

Number of assembly locks required for the horizontal joints of all standard panels:

- Four AS assembly locks for panel width 135 cm
- Three AS assembly locks for panel width 90 cm
- Two AS assembly locks for a panel width less than 90 cm

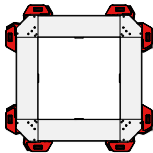

Fig. 69.2

Description	Ref. No.
AS/ST outside corner 330.....	22-140-10
AS/ST outside corner 270.....	22-140-20
AS/ST outside corner 135.....	22-140-30

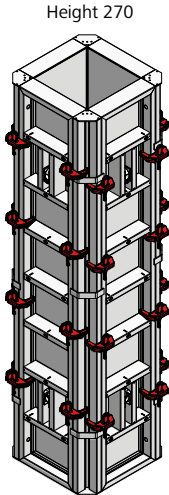

Fig. 69.3

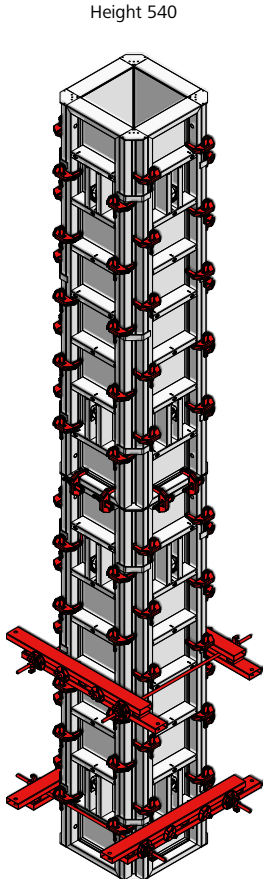

Fig. 69.4

Wall Formwork

Closing the tie holes

The tie holes in the concrete are closed using the XT plug D46 (Figures 70.1 and 70.2). It is made of plastic and is suitable irrespective of whether the XT tie rod DW or the XT taper tie is used (see page ST-XT-15) and irrespective of whether the XT sealing cone 5 AL or the XT sealing cone 10 AL is used (see page ST-XT-17).

For architectural-concrete requirements, the XT fibre concrete plug 47 x 8.5 is used to close the holes in the concrete (Figures 70.3 and 70.4). It is glued in place using concrete glue.

To do this, the XT sealing cone 5 AL preinstalled in the formwork panel must be replaced with the XT sealing cone 10 AL before pouring.

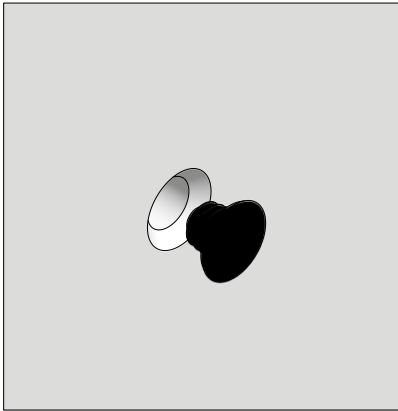

Fig. 70.1

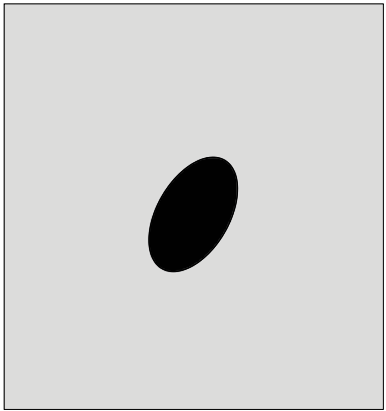

Fig. 70.2

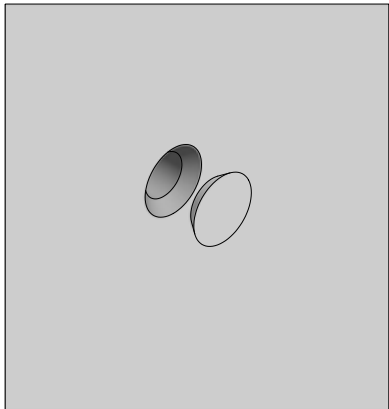

Fig. 70.3

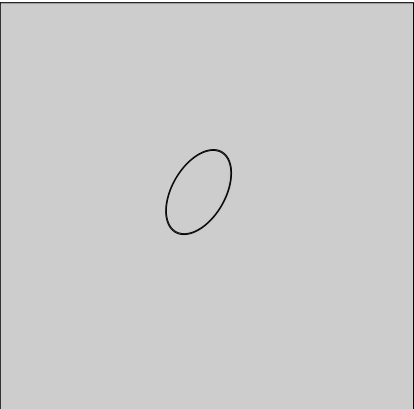

Fig. 70.4

Description	Ref. No.
XT plug D46	29-902-81
XT fibre concrete plug 47 x 8.5	29-902-82
Concrete glue (A + B)	53-210-70
XT sealing cone 5 AL20	29-902-34
XT sealing cone 5 AL17	29-902-33
XT sealing cone 10 AL20	29-902-35
XT sealing cone 10 AL17	29-902-42

Sealing the tie holes

To seal the tie holes against water pressure, the following can be used:

- FB active stop XT 20 (Fig. 71.1 and page ST XT-72), consisting of a tapered fibre-reinforced concrete core and an integrated expansion seal, or
- MEVA multi-stop 23 (Fig. 71.2 and page ST XT-73), material: TPE – thermoplastic elastomer

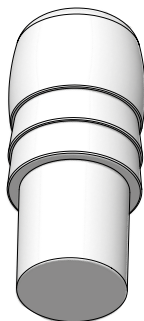

Fig. 71.1



Fig. 71.2

Test reports are available for both sealing methods.

Note

- The previous use of the tying method with XT taper tie is the prerequisite for the use of these sealing methods (Table 71.3).
- The seal must always be installed on the wall side on which the water emerges. This is generally the outside of the wall (initial-formwork side).
- The sealing of the tie holes does not depend on the weather conditions.

Seal	Sealing against hydrostatic pressure	XT taper tie 20	XT taper tie 23
FB active stop 20	5 bar (50-meter water column)	Yes	No
MEVA Multi-Stop 23	Recommended continuous pressure of 1.0 bar (= 10-meter water column) with a maximum short-term peak pressure of 1.8 bar (= 18-meter water column) (t < 1 d), short-term water pressure of 4.0 bar (= 40-meter water column) Resistant, inter alia, to salt water, diesel, bitumen and caustic soda lye.	No	Yes

Table 71.3

Description	Ref. No.
FB active stop XT 20 set.....	29-902-41
MEVA multi-stop 23.....	29-902-43

Sealing the tie holes – FB active stop XT 20

Can be used in conjunction with XT sealing cone 5 AL20 and AL17 as well as XT sealing cone 10 AL20 and AL17.

Installation of the FB active stop XT 20:

1. Clean the tie hole. It must be free of contamination and grease and have a smooth surface (Fig. 72.2).

2. Moisten the FB active stop, insert it from the final-formwork side (large tie hole diameter) with the end with the integrated expansion seal first, then hit it with a rubber mallet until it is flush.

3. Drive the FB active stop in further using the hammering aid (delivered with the FB active stop XT 20 set) and hammer (Fig. 72.4). To enable the FB active stop to be positioned correctly in the tie hole, the hammering aid has marker rings for the wall thicknesses 15, 20, 24, 25 and 30 cm. For this purpose, it is shortened at the marker ring corresponding to the desired wall thickness. The hammering aid must be driven in up to the stop (Fig. 72.4). If the wall thickness differs from those listed above, the required length of the hammering aid can be calculated using the following formula:
 Wall thickness (in cm) - 6.7 cm
 (see example below).

4. Remove the hammering aid and plug the tie hole (Fig. 72.5 and page ST XT-71).

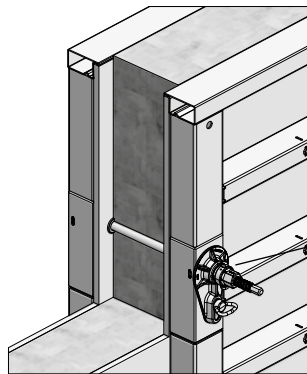

Fig. 72.1

Final-formwork side (large tie hole diameter)

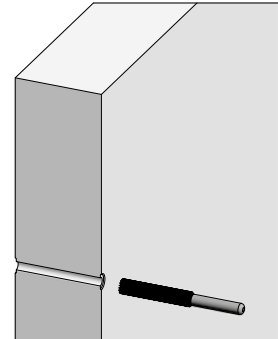

Fig. 72.2

Marker rings for wall thickness:

- 15 cm
- 20 cm
- 24 cm
- 25 cm
- 30 cm

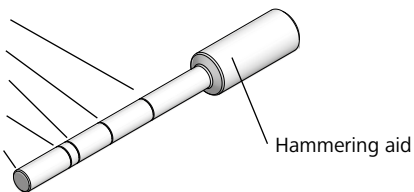

Fig. 72.3

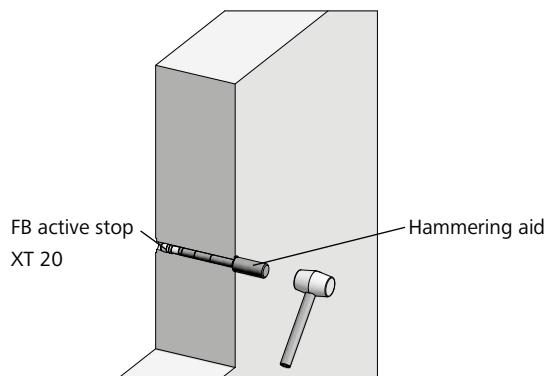

Fig. 72.4

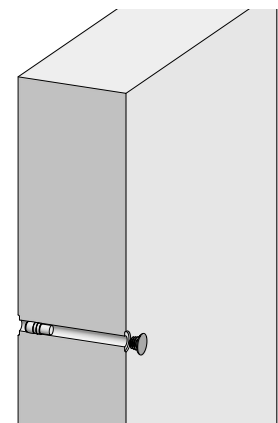

Fig. 72.5

Calculation of a different hammering aid length (e.g. wall thickness 30 cm):

Length of FB active stop XT 20 = 5.7 cm

Insertion depth of XT sealing cone = max. 1 cm

Different hammering aid length = 30 cm - (5.7 cm + 1 cm) = 23.3 cm

Description	Ref. No.
FB active stop XT 20 set.....	29-902-41

Sealing the tie holes – MEVA multi-stop 23

Can be used in conjunction with XT sealing cone 5 AL20 and AL17 as well as XT sealing cone 10 AL20 and AL17.

The following is required for assembly (Fig. 73.1):

- Cleaning brush
- MEVA hammering aid
- Cotter pin
- Hammer (1000 g)



Fig. 73.1



Fig. 73.2

Installation of the MEVA multi-stop 23:

1. Remove dirt and dust from the tie hole using the cleaning brush (Fig. 73.2).

2. Insert the MEVA multi-stop 23 into the tie hole (Fig. 73.3).



Fig. 73.3

3. Adjust the hammering aid to suit the wall thickness. To do this, insert the cotter pin into the corresponding hole (Fig. 73.4).



Fig. 73.4

4. Push the MEVA multi-stop 23 into the tie hole using the hammering aid (Fig. 73.5).



Fig. 73.5

5. Using the hammering aid, drive the MEVA multi-stop 23 into the tie hole (Fig. 73.6).



Fig. 73.6

6. Drive the hammering aid in until the cotter pin is up against the wall (Fig. 73.7).



Fig. 73.7

The MEVA multi-stop 23 is now in the correct position (Fig. 73.8).

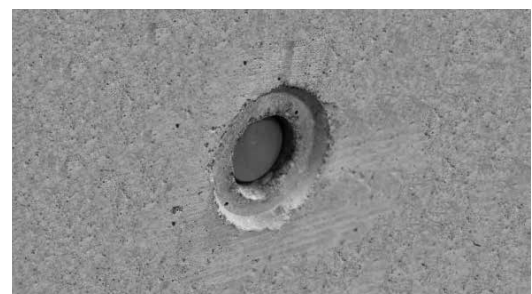

Fig. 73.8

Description	Ref. No.
MEVA multi-stop 23.....	29-902-43
MEVA multi-stop hammering aid	29-306-25

Overview of cones and plugs

The following overview lists all cones and plugs that are used depending on the tying method.

For detailed information about their use refer to the corresponding chapters in this Technical Instruction Manual.

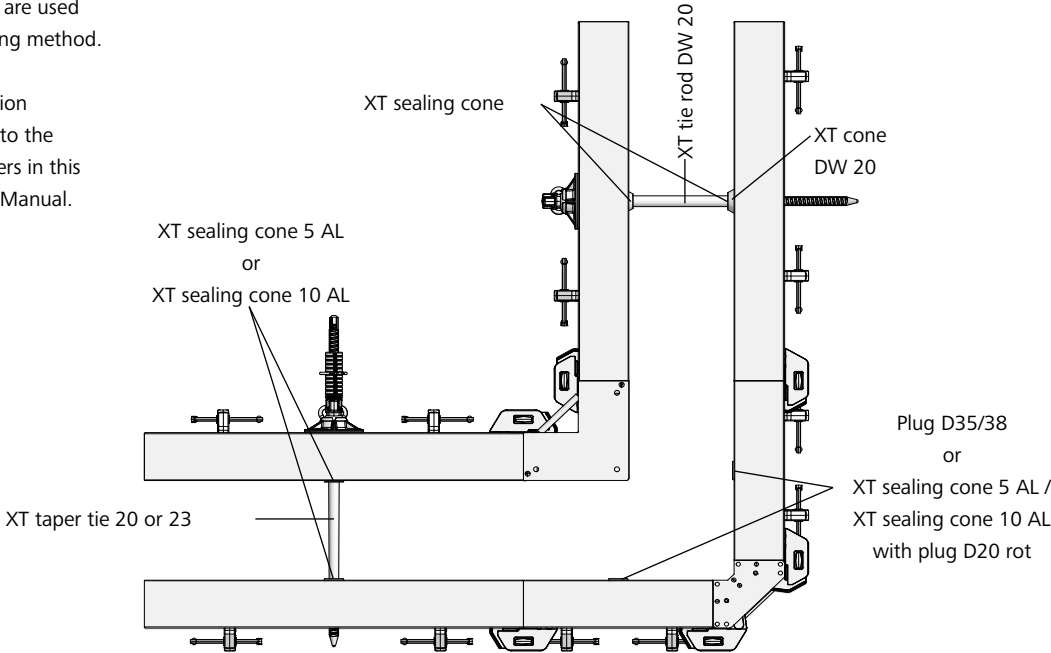
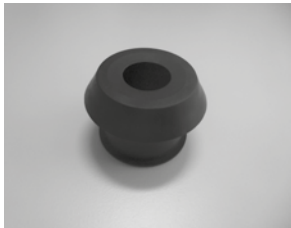

Fig. 74.1



XT sealing cone
5 AL20 29-902-34
5 AL17 29-902-33



XT sealing cone
10 AL20 29-902-35
10 AL17 29-902-42

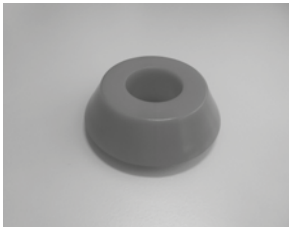

XT cone DW 20
29-902-37



Plug D35/38
29-902-71



Plug D20 red
29-902-63



XT sealing plug D46
29-902-76

Description	Ref. No.
XT sealing cone 5 AL20	29-902-34
XT sealing cone 5 AL17	29-902-33
XT sealing cone 10 AL20	29-902-35
XT sealing cone 10 AL17	29-902-42
XT cone DW 20	29-902-37
Plug D35/38	29-902-71
Plug D35/38 without imprint ..	29-902-72
Plug D20, red	29-902-63
Plug D20, red without imprint	29-902-62
XT plug D46	29-902-81
Plug D32	29-902-58
XT fibre concrete plug 47 x 8.5	29-902-82



Plug D32
29-902-58

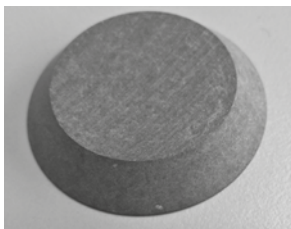

XT fibre concrete plug 47 x 8.5
29-902-82

Transport

The lifting hook 40 (Figures 75.1 and 75.3) can be used with any 4-rope crane sling on the construction site to transport horizontal panel stacks (Fig. 75.2). Always use four hooks at once. To calculate the permissible load-bearing capacity, assume that only two hooks are used.

Attention

A lifting hook must only be used if its eccentric is easy to turn or falls automatically into the locked position (Fig. 75.4). Never use a lifting hook if you need force to turn its eccentric. Turning the eccentric with force may not lock the lifting hook but only make it appear to be in the locked position. This may cause the lifting hook to slip out when lifting the panel stack.

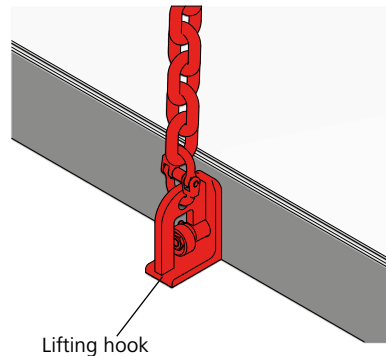

Fig. 75.1

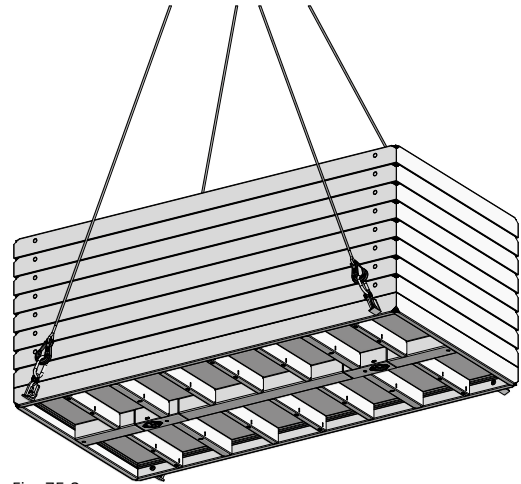

Fig. 75.2

Technical data

- Weight 2.0 kg
- Maximum capacity of each hook: 10 kN (1 ton)
- Maximum capacity for each stack: 20 kN (2 tons)
- Max. stack height:
 Three StarTec XT panels 330/270;
 four StarTec XT panels 270/240;
 nine StarTec XT panels 270/135;
 or a maximum of ten panels with a width of 90 cm or less.

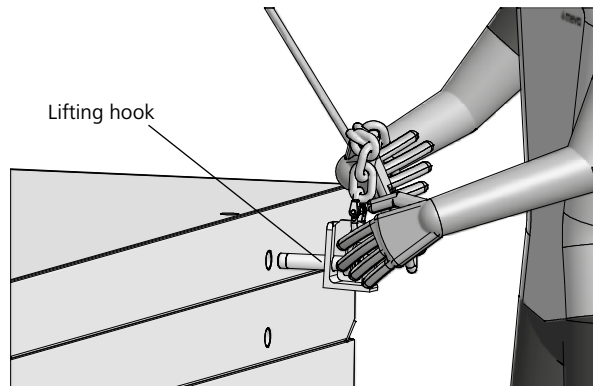

Fig. 75.3

Repositioning

When moving panel stacks, make sure the panels are secured against sliding (see page ST-XT-77).

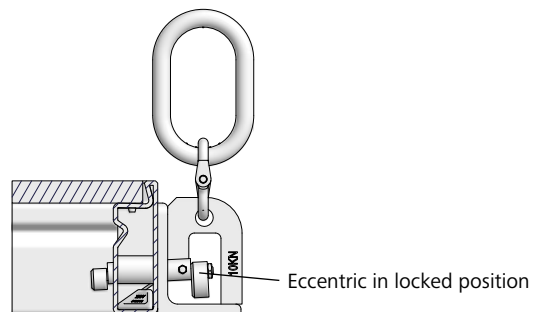

Fig. 75.4

Description	Ref. No.
Lifting hook 40	29-401-42

Wall Formwork

Transport

Stacking angle 60/40/23

With the stacking angle (Fig. 76.1) made of galvanized steel, two to five wall formwork panels of the same size with frame profile widths of 60 mm, 40 mm or 23 mm can be stacked and transported using a lift/pallet truck or a crane.

To use the stacking angle with StarTec XT, the adjustable bracket on the stacking angle must be adjusted to suit the panel frame width of 40 mm (reference dimension = 44 mm) and attached using the two integrated M8 countersunk bolts with hexagonal nuts (Fig. 76.2).

Four stacking angles 60/40/23 are required for each panel stack (Fig. 76.3).

A maximum of three stacking units may be stacked one of top of the other for storage purposes (Fig. 76.3).

The permissible load capacity is:

- 15 kN (1.5 t) per stacking angle.
- 30 kN (3 t) when using four stacking angles (total load capacity).
- 45 kN (4.5 t) when using four stacking angles (total load capacity) if it has been ensured that the load is distributed evenly over further strands or if the permissible loading of the individual strands is not exceeded in the event of an unequal load distribution.

Assembly

1. Insert a stacking angle 60/40/23 at each corner of the StarTec/AluStar panel so that the panel lies on the supporting surface with the facing side upwards. This protects the facing when it is being moved by a forklift truck.
2. Insert the next panel into the adjustable brackets from above. The second panel secures the stack, which can now be moved.
3. If required, insert further panels (up to a total of five).

Note

- A 4-rope crane sling must always be used when transporting using a crane.
- The opening angle of the crane sling must not exceed 60° (Fig. 76.4).
- Observe the operating instructions for the stacking angle 60/40/23.

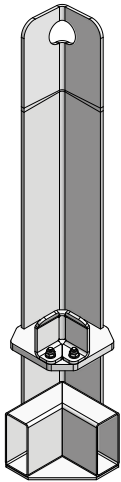

Fig. 76.1

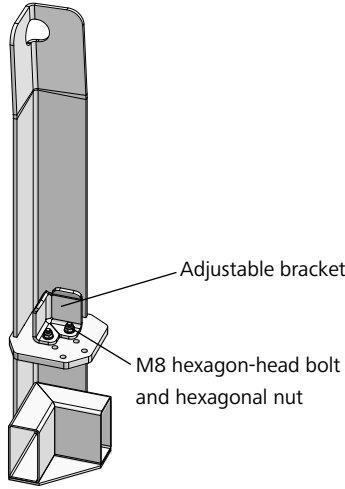

Fig. 76.2

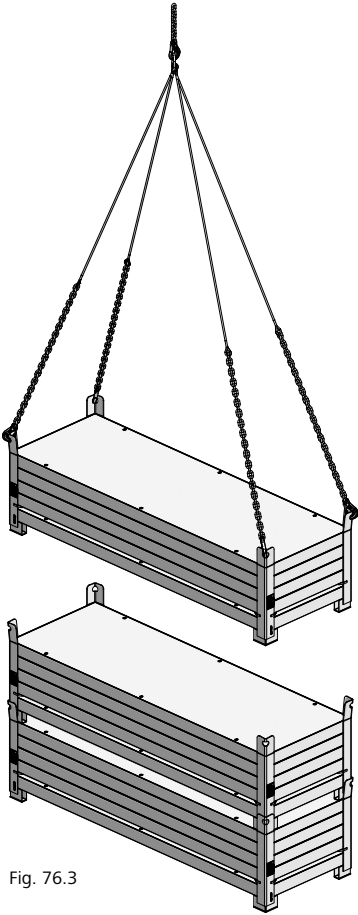
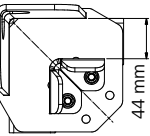

Fig. 76.3

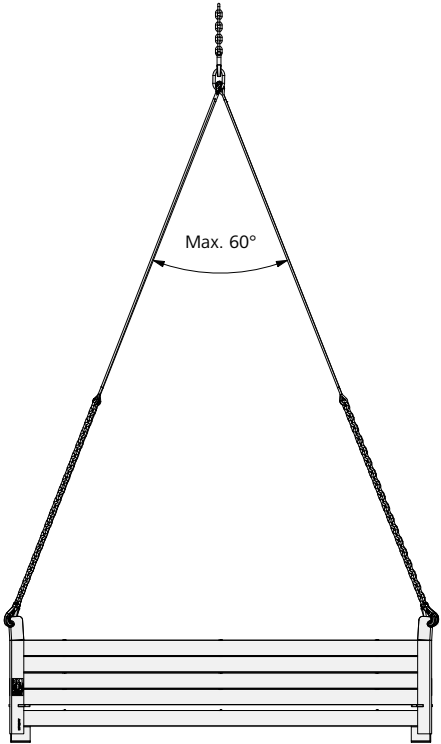

Fig. 76.4

Description	Ref. No.
Stacking angle 60/40/23.....	29-305-45

Wall Formwork

Transport

Make sure that all material is secured properly.

Guidelines

Use one ratchet strap per metre of cargo. This means that 14 ratchet straps are required for a fully loaded truck with a trailer length of 13.60 m.

Depending on their size, the StarTec XT panels require two or three straps. Due to their low weight, StarTec corners require only two straps.

When moving panel stacks, make sure the panels are secure. MEVA secures the StarTec XT panels with anti-slip mats.

The transport safety devices should also be used when returning the material from building site.

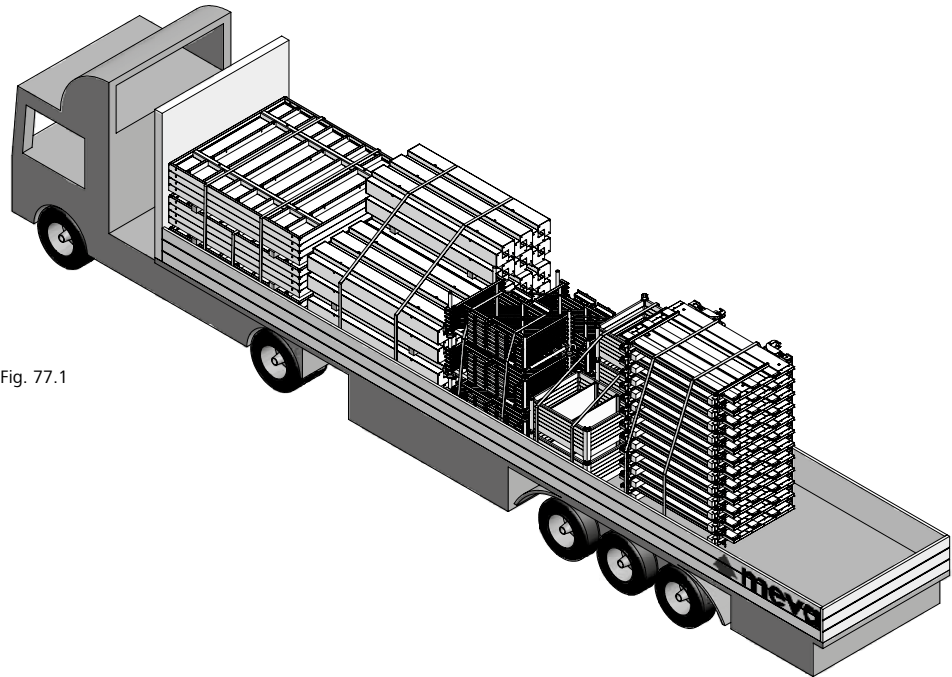

Fig. 77.1

Anti-slip mats per panel:

330 cm = 6 anti-slip mats per panel

270 cm = 4 anti-slip mats per panel

135 cm = 4 anti-slip mats per panel

330/270 and 270/240 = 10 anti-slip mats per panel

Further applications for StarTec XT

STB support frame for single-sided formwork (Fig. 78.1)

The StarTec XT formwork together with STB support frames can also be used when concrete has to be poured against earth, rock, an existing wall or the like, i.e. when a single-sided formwork is required.

STB 300/300 plus support frames allow for walls up to 4.50 m, while STB 450 support frames together with height extensions allow for wall heights of up to over 12 m.

Please observe the Support Frame STB Technical Instruction Manual.

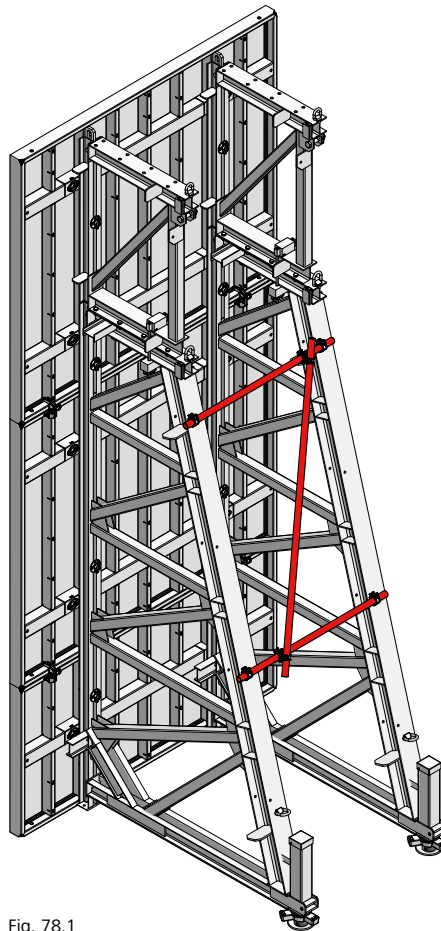

Fig. 78.1

KLK 230 climbing scaffold (Fig. 78.2)

When forming high walls, façades, pillars, staircase or elevator shafts, the StarTec XT formwork can be placed and secured on the KLK 230 climbing scaffold.

Please observe the KLK 230 Climbing Scaffold Technical Instruction Manual.

Please note

The use of STB support frames and climbing scaffolds requires detailed formwork planning.

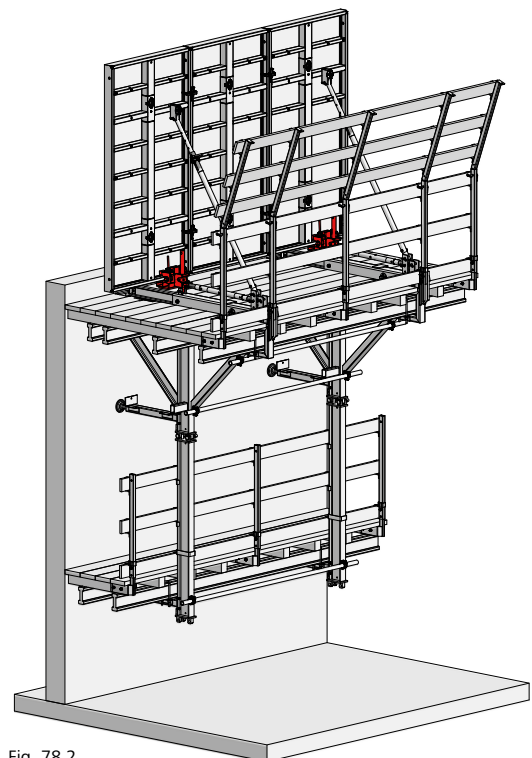

Fig. 78.2

Wall Formwork

Services

Cleaning

The formwork is cleaned professionally using industrial equipment upon return.

Reconditioning

Reconditioning is carried out as follows: The frames are checked and, if necessary, blasted, coated with a high-quality cured powder coating, and provided with a new facing. As long as the formwork equipment still has its full load capacity, correct dimensions and is fully functional, reconditioning will always be a more economical solution than purchasing new formwork. Please note that the cleaning and reconditioning service is not available in all countries in which MEVA does business.

Rentals

As we have a comprehensive range of equipment in stock, we offer our customers the option of renting supplementary material at peak times. The MEVA logistics centre guarantees rapid delivery throughout Europe. We also give prospective customers the chance to test MEVA formwork so they can see its benefits for themselves in actual use.

RentalPlus

For a flat-rate fee MEVA's "fully comprehensive insurance" for rental formwork and equipment covers all secondary costs that occur after return (excludes losses and write-offs). For the customer this means: Costing certainty instead of additional charges, an earlier end of the rental period and thus lower rental costs because you save the time required for cleaning and repairs.

Formwork drawings

Our application engineers worldwide work with CAD systems. This ensures that you always receive optimum formwork solutions and practice-oriented formwork and work cycle plans.

Special solutions

We can help with special parts, custom-designed for your project, to supplement our standard formwork systems.

Structural calculations

Generally, this is only necessary for applications such as single-sided formwork where the anchor parts are embedded in the foundation or the base slab. On request, we can perform structural calculations for such applications at an additional charge.

Formwork seminars

To ensure that all our products are used properly and efficiently, we offer formwork seminars. They provide our customers with a good opportunity to keep themselves up to date and to benefit from the know-how of our engineers.

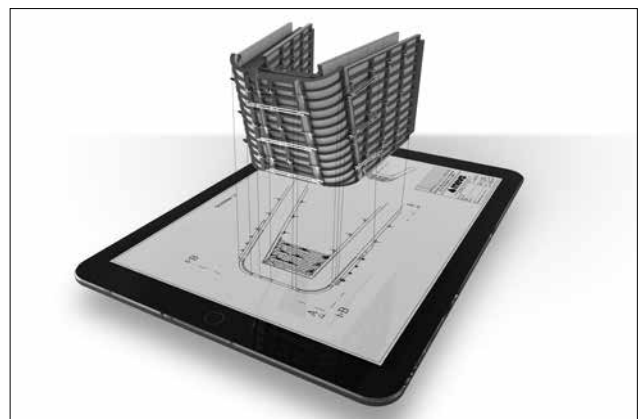

Notes

A large grid of small dots for taking notes.