



Mammut XT

Technical Instruction Manual



Product features

The Mammut XT wall formwork is a crane-dependent frame formwork system made of hot-dip galvanised and post-treated steel. It is ideal for use in high-rise, public, commercial and industrial construction as well as civil engineering projects.

With its integrated combination tie hole recessed in the frame, the system can be tied in three ways, both from one side and from two sides, without needing to perform assembly or disassembly measures on the panel. The option of choosing the tying method best suited to the project significantly reduces the formwork placing time. Furthermore, the combination tie hole enables the panels to be stacked without having to remove parts beforehand.

The Mammut XT panel dimensions and the absolutely symmetrical inner tie holes result in a uniform tie hole pattern and a uniform joint pattern for the highest architectural-concrete requirements.

The Mammut XT panels are equipped with the 20 mm thick alkus facing made of polypropylene and aluminium. The facing is riveted to the panel on the pouring side. In addition, the facings are protected with silicone. The solid plastic facing has all the positive properties of plywood plus important advantages: longer lifespan, greater load-bearing capacity, better nail-holding ability, fewer and easier repairs, 100% recyclability.

The MEVA multi-function profile with welded-in DW-threaded nuts makes the attachment of accessories easier, for example:

- Push-pull props and alignment rails with flange screws
- Walkway brackets with integrated self-locking pin
- DW tie rods of any length that are used to bridge problem areas.

The maximum permissible fresh-concrete pressure is 100 kN/m² (when using tie rods with a permissible working load of 160 kN), see page XT-27. The fresh-concrete pressure according to DIN 18218:2010-01 can be determined easily and precisely with MEVA's online concrete pressure calculator available at www.meva.net.

Safety equipment

The safety system MIS – MEVA Integrated Safety was developed for Mammut XT and prevents falling accidents and at the same time increases occupational safety and work efficiency. For more information refer to the MIS – MEVA Integrated Safety Technical Instruction Manual.

Abbreviations, measurements, figures and tables, etc.

The abbreviation XT is used for the Mammut XT. DIN means Deutsche Industrie-Norm (German Industrial Standard). E DIN (E = Entwurf / draft) means that the DIN is in draft status and not yet approved. Any further abbreviations are explained where they are used for the first time.

TÜV means Technischer Überwachungsverein. This is the independent German organisation that tests the safety of technical installations, machinery and motor vehicles. If a product passes the test, it is permitted to carry the GS seal. GS stands for Geprüfte Sicherheit (approved safety).

Measurements: This manual uses the metric system, i.e. m (for metre), cm (for centimetre) and mm (for millimetre).

Non-defined dimensions are in cm.

The page numbers in this manual start with XT. The figures and tables are numbered per page. Depending on its product abbreviation, a cross reference in the text refers to a page, table or figure in this or in another manual. This is indicated by the product code with which the cross-reference begins.



Please note

This Technical Instruction Manual contains information, instructions and tips that describe how to use the MEVA equipment on the construction site in a proper, quick and economic way. Most examples shown are standard applications that will occur in practice most often. For more complicated or special applications not covered in this manual, please contact the MEVA experts for advice. They will help you without delay.

When using our products, the federal, state and local occupational health and safety regulations must be observed. Please observe the assembly instructions that your local contractor or employer has created for the site on which the MEVA equipment is used. Such instructions are intended to minimise site-specific risks and must contain the following details:

- The order in which all working steps including assembly and disassembly must be carried out
- The weight of the panels and other system parts
- The type and number of ties and braces as well as the distance between them
- The location, number and dimensions of working scaffolds including the working area and fall protection equipment required
- Attachment points for panel transport by crane. With regard to panel transport, please observe this manual. Any deviation will require structural verification.

Important: Generally, only well-maintained material may be used. Damaged parts must be replaced. Use only original MEVA spare parts for replacement.

Attention: Never wax or oil assembly locks!

Contents

Formwork assembly and stripping.....	4
The Mammut XT panel	8
Parking positions	10
Overview of panels	11
Free combination of vertical and horizontal panels.....	12
Tie hole and joint pattern.....	13
alkus all-plastic facing	14
Panel connection	15
Tying methods	16
The combination tie hole	17
Sealing the combination tie hole.....	18
Single-sided tying with XT tie rod DW 20 and plastic tube	19
Single-sided tying with XT taper tie 20.....	21
Single-sided tying with XT taper tie 23.....	23
Single-sided tying with XT taper tie 20 or 23	25
Two-sided tying with DW tie rod and plastic tube	26
Rules for concrete pouring and rate of placing.....	27
Flatness of surface	28
Attachment of accessories	29
Wall braces.....	30
Workplaces.....	33
Crane Hook	39
90° corner	40
90° corner – Single-sided tying	42
90° corner – Two-sided tying	43
90° corner – Inside corner	44
90° corner – Outside corner.....	45
90° corner – Height-extended outside corner	47
Hinged corner.....	48
Stripping corner.....	50
Length compensation – Mammut XT compensation panel.....	58
Length compensation – Filler / timber filler	59
Length compensation – Filler widths.....	60
T wall connection	61
Wall offset.....	64
Stop ends	65
Pilasters	67
Differences in height.....	68
Horizontal panels.....	69
Stabilisation of units	70
Substitution of ties.....	71
Crane ganging	73
Column formwork – With standard panels.....	75
Closing the tie holes	76
Sealing the tie holes.....	77
Sealing the tie holes – FB active stop XT 20	78
Sealing the tie holes – MEVA multi-stop 23.....	79
Overview of cones and plugs	80
Transport with lifting hook.....	81
Transport with stacking angle 60/40/23	82
Single-sided formwork / climbing formwork	83
Transport	84
Services	85
Product list	87

Formwork assembly and stripping

Important!

When assembling and stripping formwork, strictly observe the local accident prevention rules. When using our formwork and systems always observe federal, state and local codes and regulations.

Attention

- During the entire assembly and stripping process vertical panels must be supported or secured against toppling by other means. This applies to all panel types, hence also to corner panels, curved panels, etc.
- Above a formwork height of 2.00 m both sides of the formwork must be secured against falling.

Planning

If you want to benefit fully from the efficient and economical use that the formwork offers, we recommend you first plan and prepare its use. Start planning by determining the optimum formwork quantity to be held in stock (the quantity is usually based on the amount of formwork required for a one day's work). When determining the quantity, consider the following:

- The formwork weight
- The time required for formwork assembly and stripping
- Transport of gangs from one pour to the next considerably reduces assembly and stripping effort and time
- Capacity of the lifting devices
- A logical cycle plan that takes corner configurations, reinforcements, etc. into account.

Once all these aspects have been considered, the quantities of

formwork items can be specified.

Ground

The ground on which the formwork is going to be placed should be clean, even and capable of bearing the expected load, as this will help reduce the time required for the assembly and stripping.

Panel transport

When unloading panels or moving panel stacks, make sure to use appropriate transport devices that can bear the load. For detailed information see page XT-81.

The steps required for assembly

For ergonomic reasons the outside formwork (initial formwork) is usually assembled and placed first. Start assembly in a corner or at a defined position and perform the following steps:

Step 1 – Place and brace the outside formwork (initial formwork)

Step 2 – Define and mark the pouring height, install the reinforcements and boxouts

Step 3 – Place the inside formwork (final formwork) and tie the outside and inside formwork

Refer to the following pages for a detailed description of these steps including the installation of the working platform and formwork stripping.

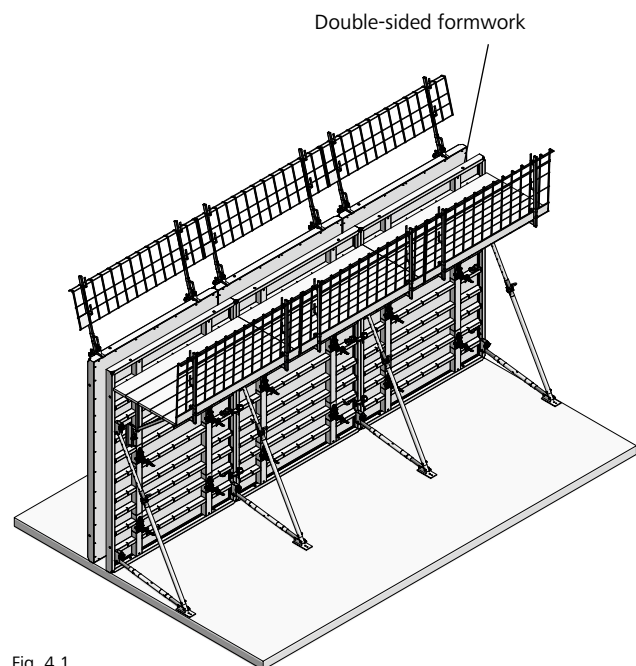


Fig. 4.1

Formwork assembly and stripping

Step 1

Place and brace the outside formwork (initial formwork)

The following description is based on a straight wall. Before starting, keep in mind:

→ When pre-assembling large panel units on an even surface, attach the wall braces and the walkway bracket as well, i.e. before performing step 1.

→ Walls of less than 6 m require a filler in the inside formwork for easy stripping (Fig. 5.3), as the formwork may otherwise become wedged and stick to the concrete when it is stripped.

1. Spray the facing with the release agent MevaTrenn pro.

2. Place the first panel and immediately attach it to the ground or concrete slab with two brace frames to prevent it falling over (Fig. 5.1). The foot plate must be firmly connected to the ground or concrete slab – in earth with two ground pegs, in concrete with two heavy-duty dowels.

After placing vertical panels, always reinforce them immediately with push-pull props or brace frames so they can withstand tensile and compressive forces and are protected against displacement and wind. The prop spacing is determined by the application. If the walkway bracket was not pre-assembled before step 1, you can now assemble and install the working platform. Fig. 6.2 on page XT-6 shows a working platform being lifted with a crane for attachment to a braced outside formwork.

3. String further panels together and connect them with M assembly locks (see page XT-15).

Panels with a height of 350 cm are usually connected with three assembly locks. However, outside corner configurations require four assembly locks (Fig. 5.2).

Step 2

Pouring height, reinforcements and boxouts

After performing step 1, the pouring height is defined and marked. Then the reinforcements and boxouts, if required, are installed.

Step 3

Place the inside formwork (final formwork) and tie the outside and inside formwork

The inside formwork is placed after the outside formwork. The inside and outside formwork are then tied firmly with tie rods (for the tying methods refer to page XT-16).

Note

Correct set-up of the formwork to the desired wall thickness is facilitated by using a stop or a mark on the ground which allows the inside formwork to be positioned exactly.

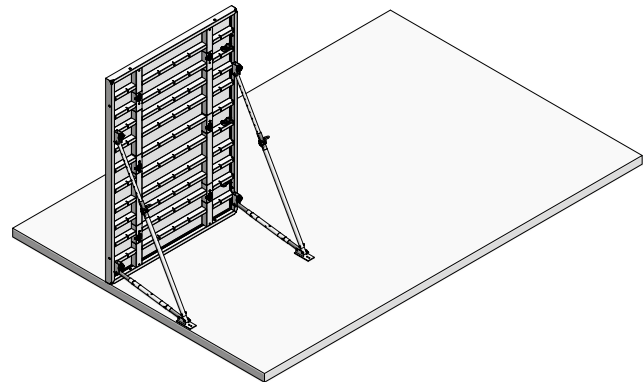


Fig. 5.1

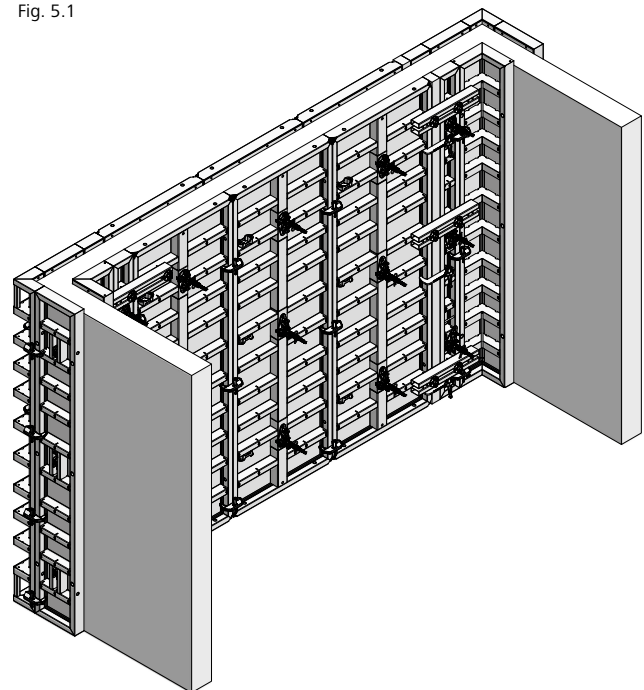


Fig. 5.2

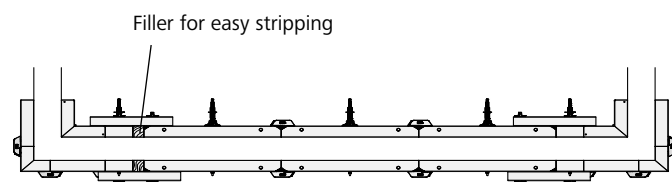


Fig. 5.3

Formwork assembly and stripping

Working scaffold

The plug-in walkway bracket is used to support the working scaffold. The maximum bracket spacing for a load of 150 kg/m² (platform group 2) is 2.50 m as defined in DIN 4420. The planking must be at least 4.5 cm thick.

The planking and walkway bracket can be firmly connected. Do not install any planks before securing the formwork with push-pull props or before tying the inside and the outside formwork.

Do not forget to attach a side railing to the working scaffold.

MEVA's SecuritBasic safety system offers platforms, ladder access and other safety equipment for safe and efficient work at all heights (see page XT-34).

Figures 6.1 and 6.2 show the folding access platform BKB 125 being used as a working scaffold.

Pouring concrete

Once you have placed, tied, braced and closed the formwork, you can start pouring concrete. When doing so, observe the permissible rate of placing taking the setting behaviour and the consistency of the cement into account (see page XT-27).

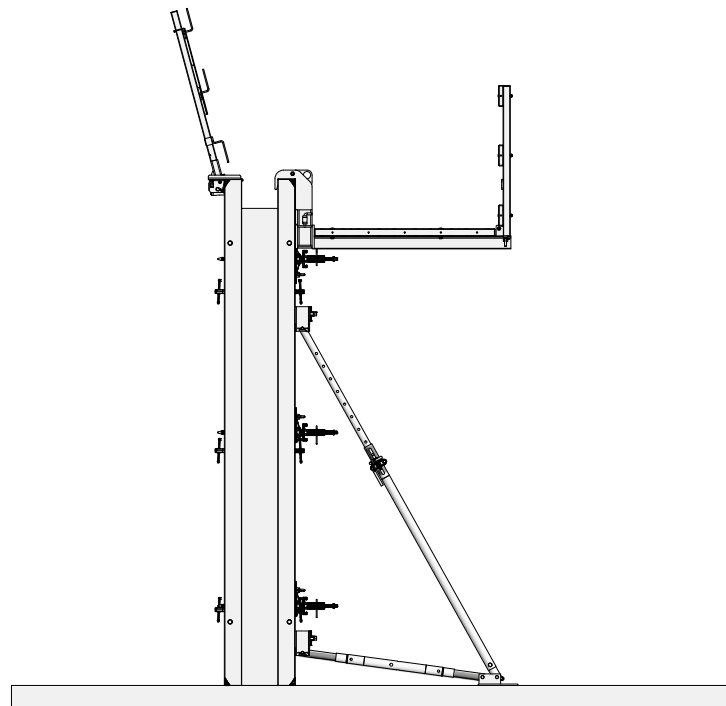


Fig. 6.1

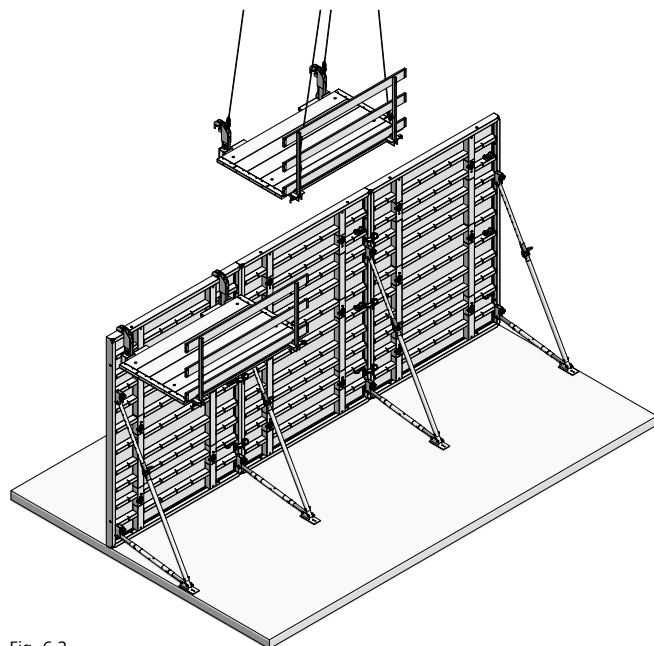


Fig. 6.2

Formwork assembly and stripping

Stripping

Do not start stripping before the concrete has set to the point where it can no longer deform. It is best to start stripping at the stop ends or at a short corner. Start stripping with the inside formwork. Stripping of both the outside and inside formwork is performed as follows:

1. Remove the tie rods section by section. (for the tying methods refer to page XT-16). Make sure the unbraced formwork is immediately secured to prevent it falling over or strip it immediately.
2. On the formwork panels or large panel units the assembly locks are removed at the joints, and the panels or panel units are then lifted out by hand or by crane. Before transporting by crane, the formwork must be detached from the concrete!
3. Clean the facing and remove any concrete. Before the next use, spray the facing with the release agent MevaTrenn pro (for alkus facings). Observe the operating instructions for the alkus facing.

Note

The release agent must not be stored in galvanized containers.

Please note

When stripping manually, detach and disassemble the working scaffold and the brace frames before stripping the panels.

When transporting large panel units with a crane, the working scaffold and wall braces are moved together with the panel units. While vertical, all components are cleaned and sprayed with release agent before being lifted together to the next cycle (see pages XT-73 and XT-74).

If there is no further use for the panel units, the working scaffold and wall braces are detached and disassembled in a horizontal position, and cleaned and stacked for transport.

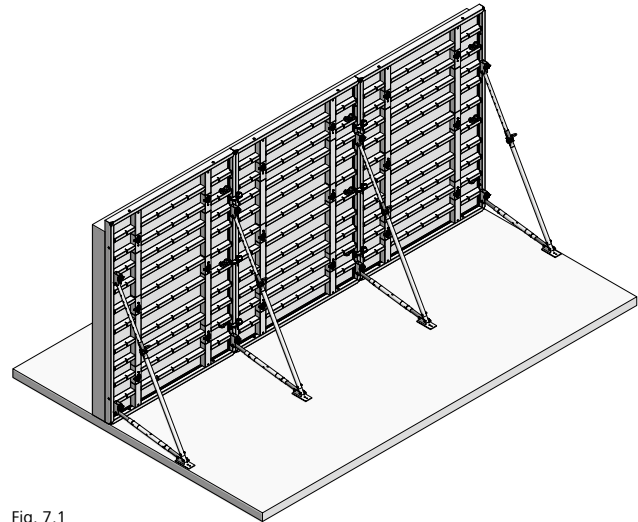


Fig. 7.1

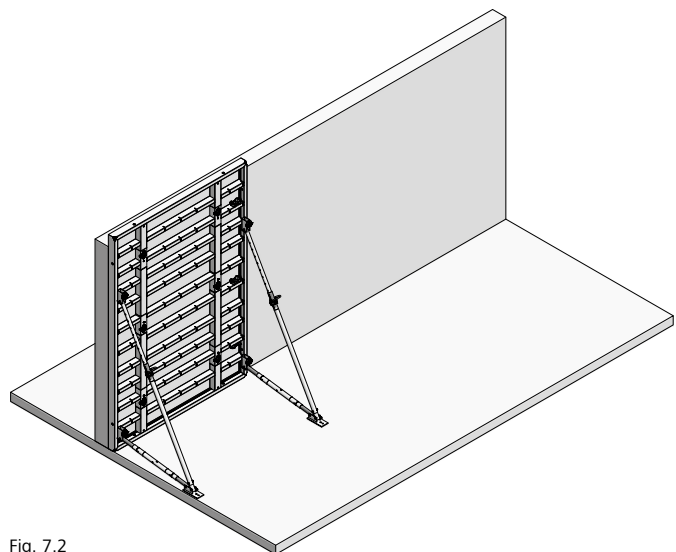


Fig. 7.2

Wall Formwork

The Mammut XT panel

The Mammut XT panel with internal combination tie holes (Fig. 8.1).

Combination tie hole with rotating sphere for single- and two-sided tying (Fig. 8.2).

Panel connection with the M assembly lock in the continuous groove (Fig. 8.3).

Cross stiffener made of sturdy closed steel profile with welded-in DW 15 threaded nuts for fast and solid attachment of accessories (Fig. 8.4).

Transport hole to attach the crane sling 60, allowing for fast loading and unloading of panel stacks or their relocation at ground or slab level (Fig. 8.5).

The steel frames are made of closed hollow profiles with welded-in mitred joints. The profiles are provided with a groove and edge protection. Panels with a width of 100, 125 and 250 cm are equipped with four bump notches (Fig. 8.6) that are welded in diagonally, allowing exact panel positioning without a hammer.

Note

For a list of the available panels including their designations and reference numbers refer to the Product List.

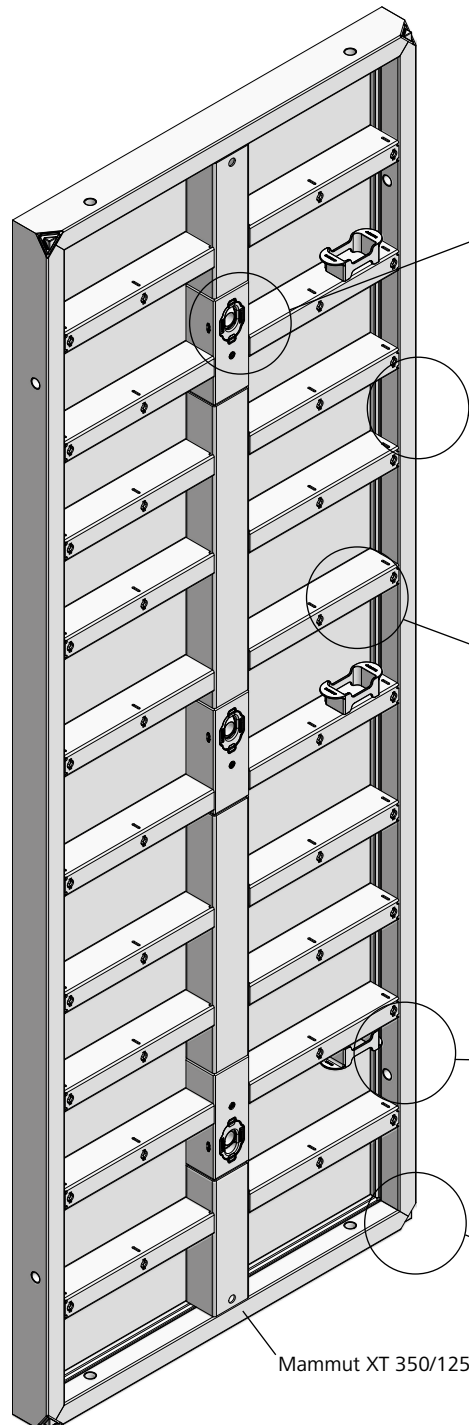


Fig. 8.1

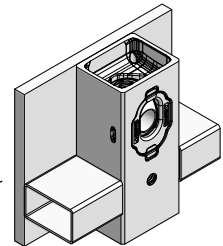


Fig. 8.2

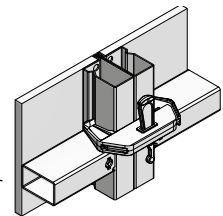


Fig. 8.3

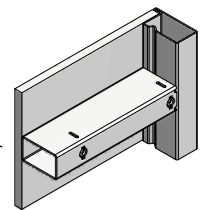


Fig. 8.4

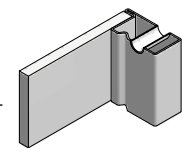


Fig. 8.5

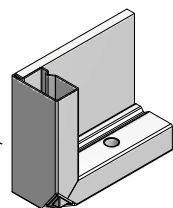


Fig. 8.6

The Mammut XT panel

Like all other Mammut XT panels, the large Mammut XT 350/250 panel (Fig. 9.1) also has internal tie holes. Thus, for the forming area of 8.75 m² only six ties are required. The 7.50 m² forming area of the Mammut XT 300/250 panel requires only four ties.

Besides internal combination tie holes, the 75 and 50 cm Mammut XT panels (Fig. 9.2) also have conical anchor sleeves in the frame. This allows for numerous formwork solutions, especially at corners. DW tie rods are used on both sides when using the frame tie holes.

The alkus all-plastic facing in pre-drilled in the area of the frame tie holes and closed off with the tie hole plug D27x20. The upper tying positions of the 300 cm high XT panels are closed off with tie hole plugs D35x20 ex works. The plugs simply have to be removed to use the tie holes. The plugs can be reused to close the holes later.

Note
Unused tie holes must always be closed with plug D35/38.

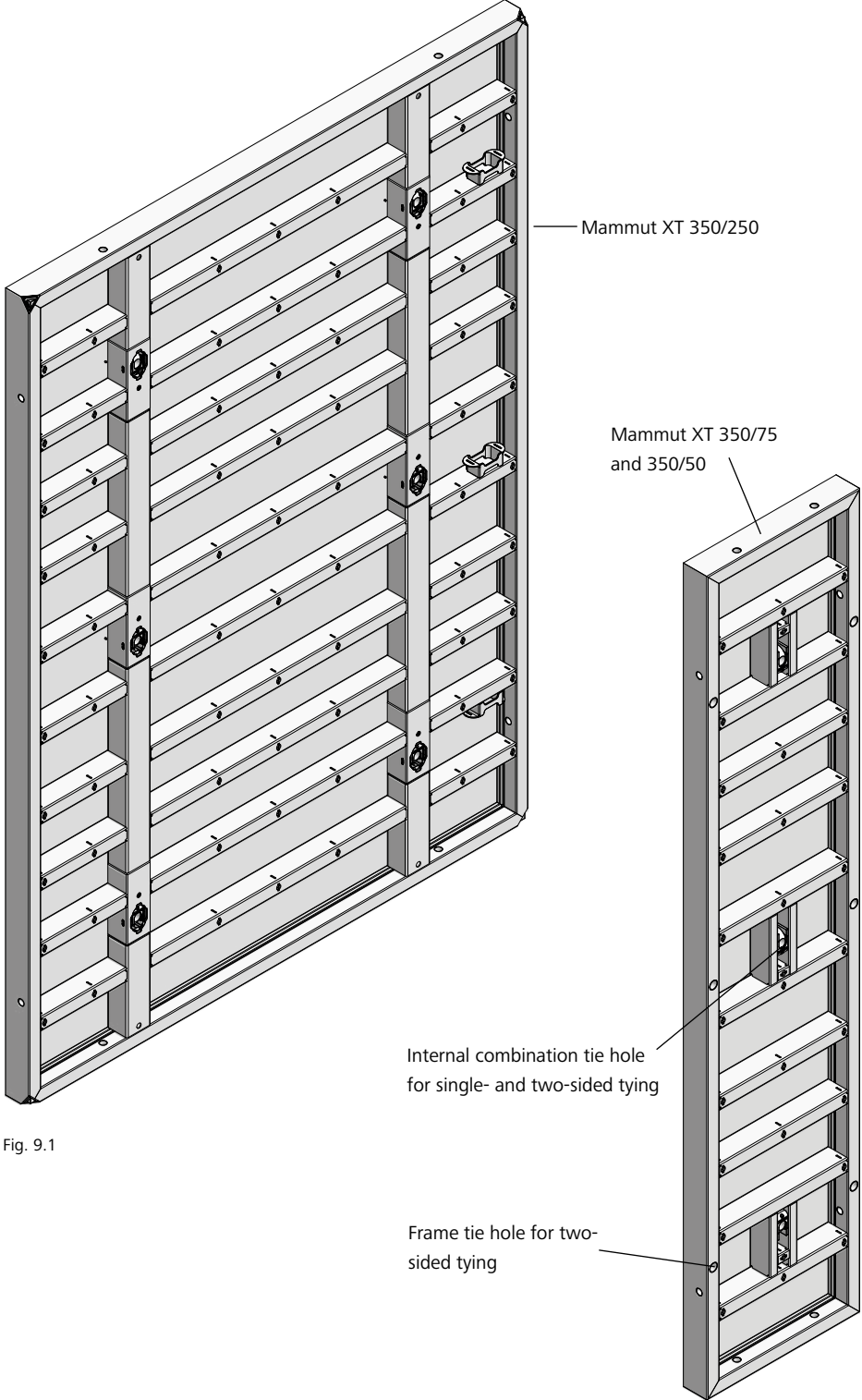


Fig. 9.1

Fig. 9.2

Description	Ref. No.
Tie hole plug	
D27x20	29-902-78
D35x20	29-902-79

Parking positions

On the Mammut XT panels with widths 250 and 125 cm the assembly lock holders are integrated into the cross stiffeners (Figures 10.1 and 10.2). They serve as parking positions for M assembly locks and Uni-assembly locks.

The tie rod holder Ø35 (Figures 10.3 and 10.4) can be attached to the multi-function profile of the vertical (Fig. 10.1) or horizontal Mammut XT panel. To install it, the tie rod holder is turned by 45° (Fig. 10.3), inserted into the multi-function nut and then turned back again. It can hold up to two XT DW tie rods, XT taper ties or DW tie rods with articulated flange nut (Fig. 10.1).

Both holders ensure that the assembly locks and tie rods are secure during the moving process.

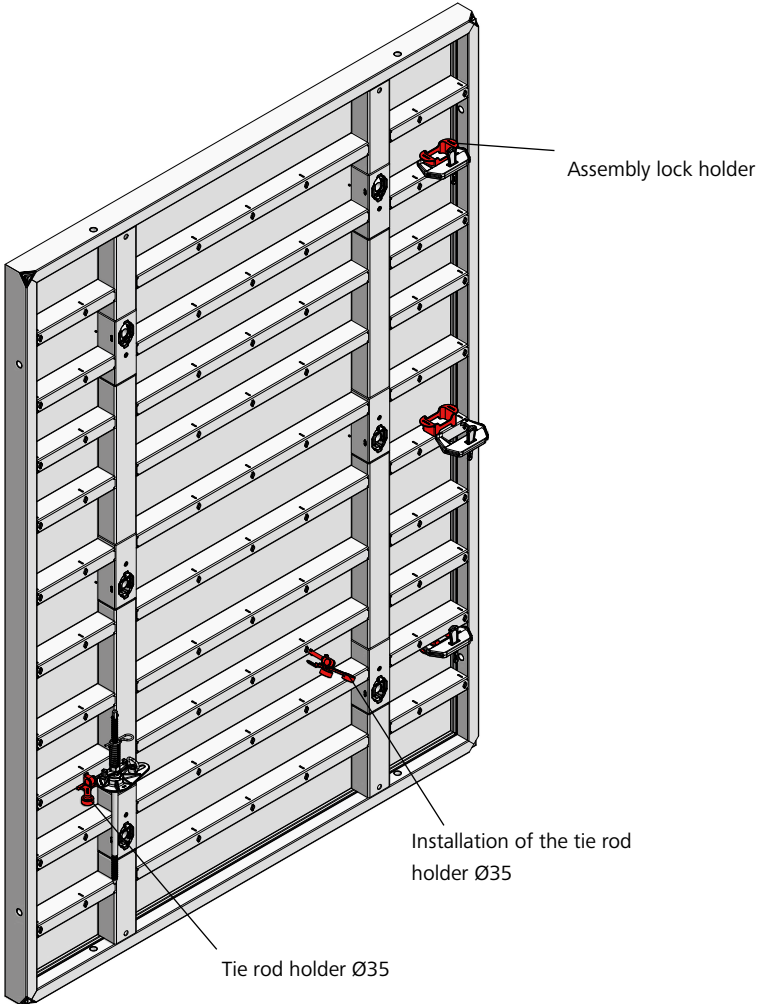


Fig. 10.1

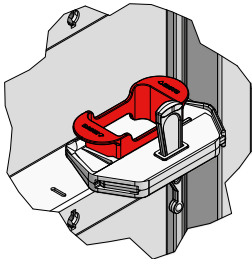


Fig. 10.2

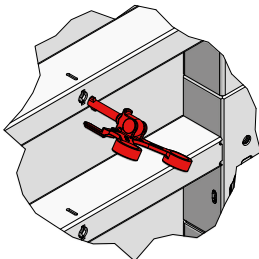


Fig. 10.3

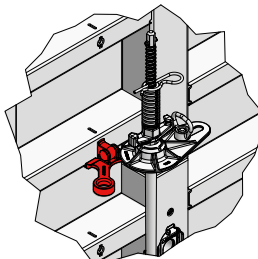


Fig. 10.4

Description	Ref. No.
Tie rod fixture Ø35.....	29-927-05

Wall Formwork

Overview of panels

Tried-and-tested panels heights and only a few panel widths provide a comprehensive range of widths and heights with increments of 25 cm (Fig. 11.1).

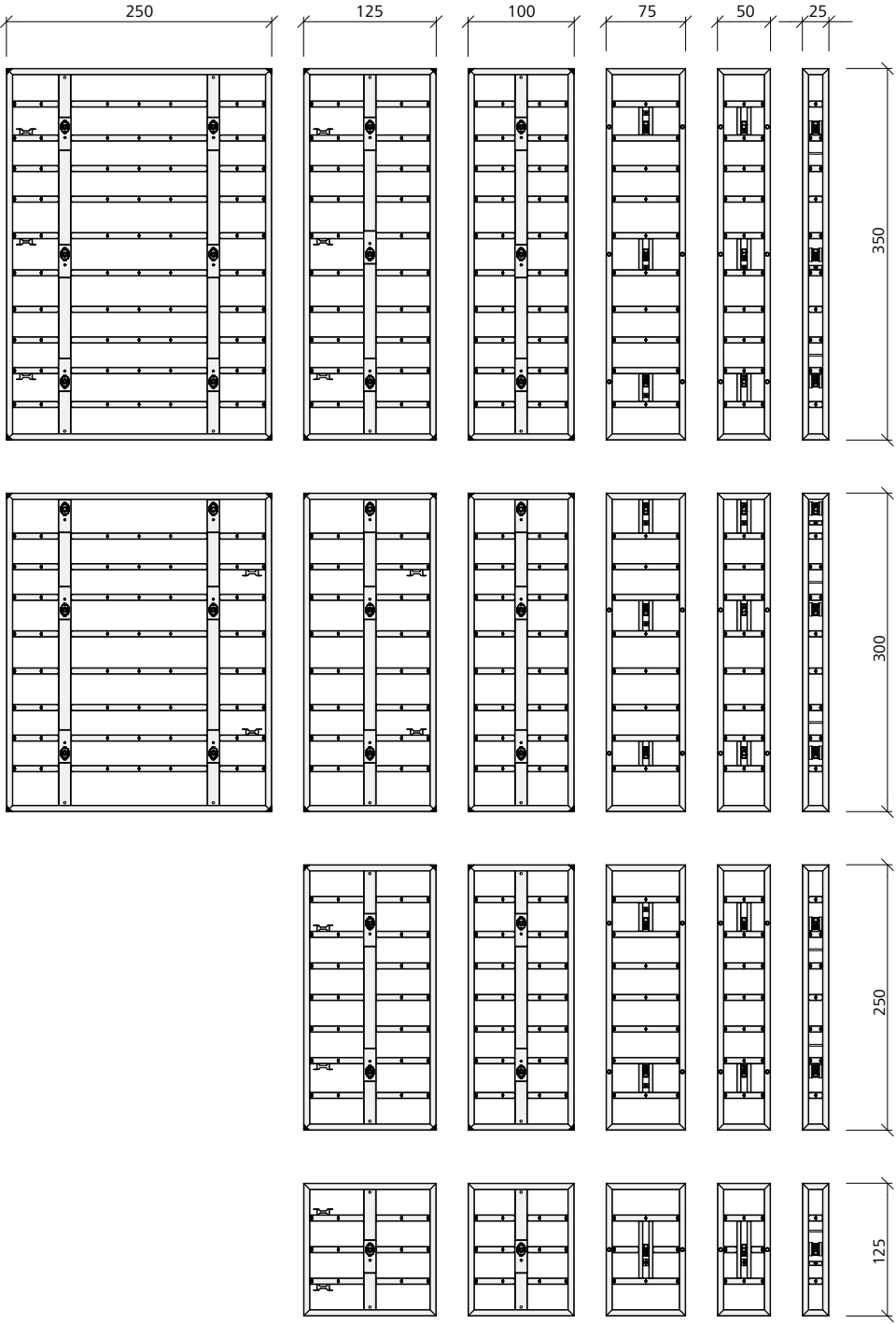


Fig. 11.1

Free combination of vertical and horizontal panels

All Mammut XT panels can be combined vertically or horizontally (Figures 12.1 to 12.3). The ability to freely combine all panels vertically or horizontally allows for economic width and height extension in increments of 25 cm (Fig. 12.3).

They must always be connected with the Mammut assembly lock (see page XT-15). The continuous grooves on the panels allow the assembly locks to be positioned steplessly.

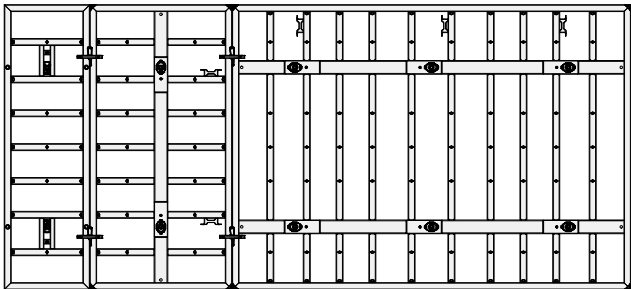


Fig. 12.1

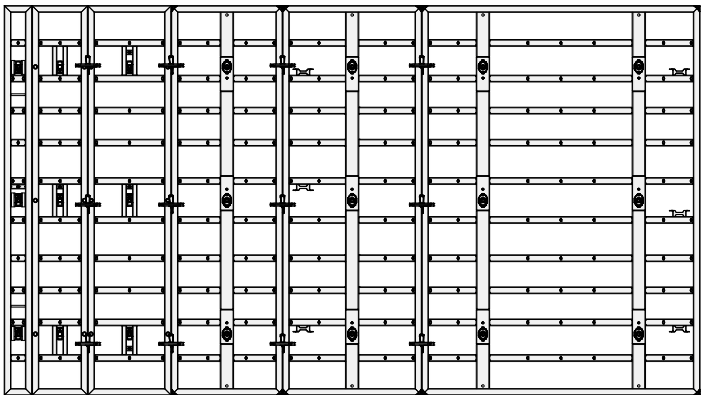


Fig. 12.2

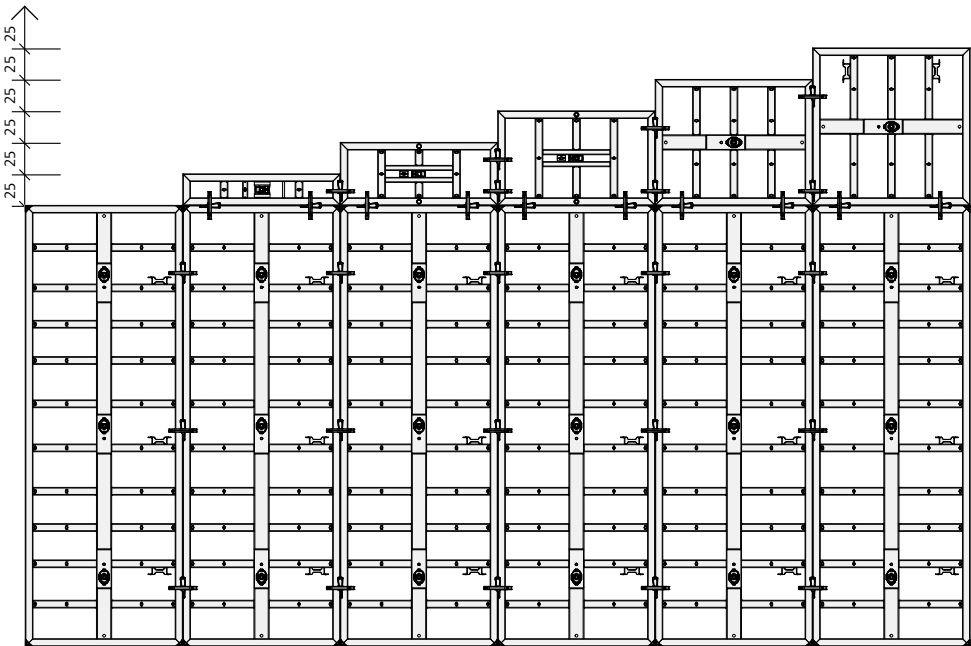


Fig. 12.3

Tie hole and joint pattern

The Mammut XT panel dimensions and the symmetrical internal tie holes result in a uniform tie hole and joint pattern for the highest architectural-concrete requirements. This applies to vertical, horizontal or a combination of vertical and horizontal formwork (Figures 13.1 and 13.2).

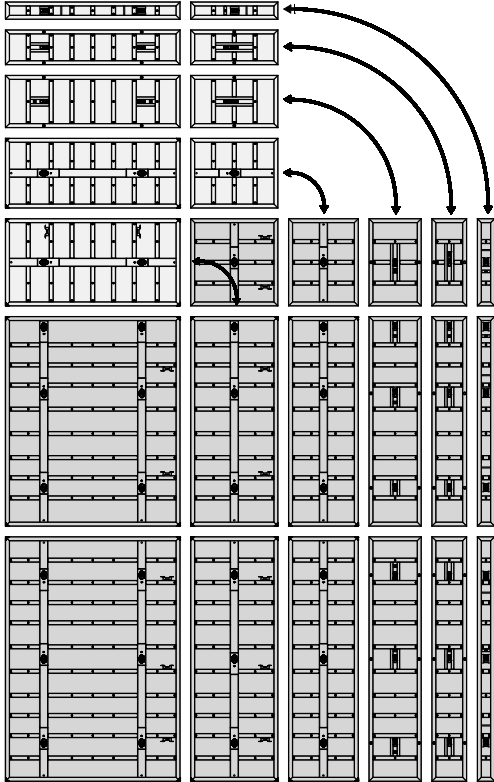


Fig. 13.1

Tie hole and joint pattern

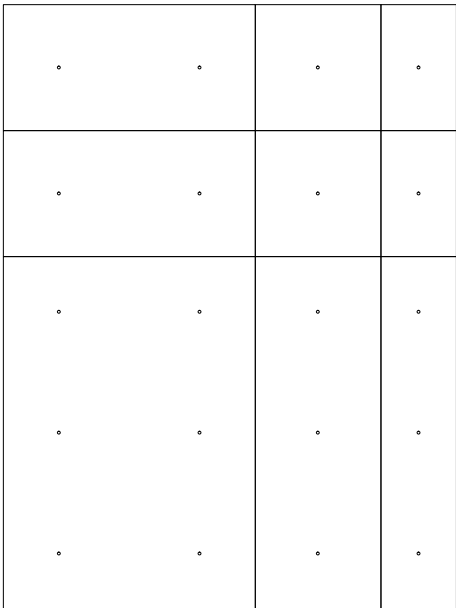


Fig. 13.2

Wall Formwork

alkus all-plastic facing

The tried-and-tested polypropylene and aluminium composite facing (Fig. 14.3) has all the positive properties of plywood plus important advantages: longer lifespan, greater load-bearing capacity, better nail-holding ability, fewer and easier repairs, 100% recyclability.

Besides the obvious advantages such as considerably reduced cleaning effort, minimum consumption of release agent and an excellent, uniform concrete finish, alkus offers substantial ecological benefits.

Substituting plastic for wood saves valuable timber resources. Also, alkus avoids the release of highly toxic dioxin that is released when burning plywood bonded with phenolic resin.

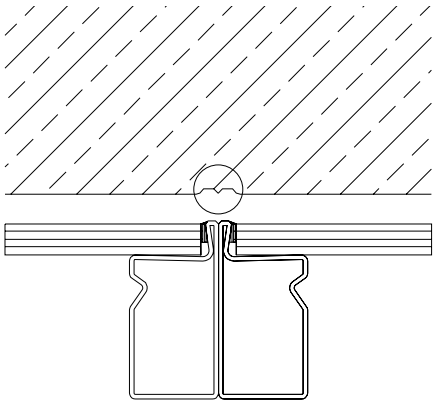


Fig. 14.1

Frame profile with plywood facing:
Negative imprint in the concrete when using panels with a conventional plywood facing

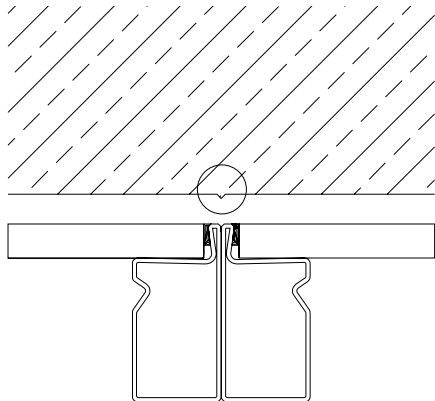
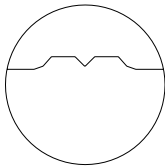


Fig. 14.2

Frame profile with alkus facing:
Smooth and even concrete surface as there are no projecting profiles

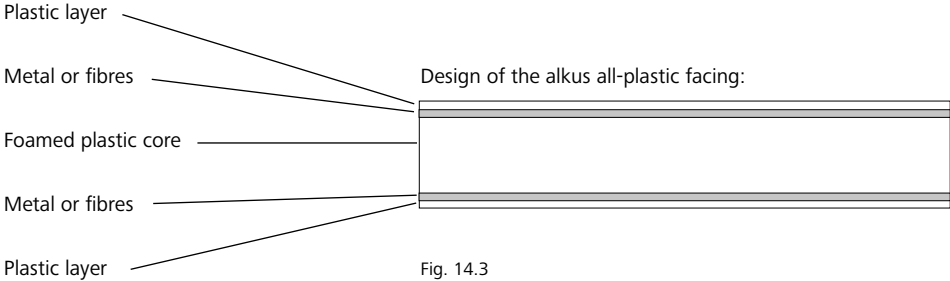
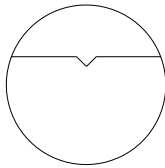


Fig. 14.3

Wall Formwork

Panel connection

Fast and efficient connection of the panels is accomplished with the M assembly lock (Fig. 15.1) whether the panels are assembled side by side or on top of each other (height-extended). The assembly lock can be attached at any position on the panel joint between the cross stiffeners. Since it weighs only 3 kg, it can be easily attached with only one hand.

Its five-point contact (Fig. 15.3) draws the panels together and aligns them. Secure connection and perfect alignment are achieved with only a few hammer blows. The assembly lock locks into a fail-safe position immediately and automatically.

Panels with a height of 350 cm are connected with three assembly locks. All other panels, whether vertical or horizontal, are connected with two assembly locks.

When pouring walls in SB3 quality (German architectural concrete class for immaculate architectural concrete surfaces), the use of an additional assembly lock is recommended to connect panels that are 250 cm high or higher.

Horizontal panel connections generally require two assembly locks.

For the quantity of assembly locks required for outside corners and columns refer to pages XT-45 to -47 as well as XT-75.

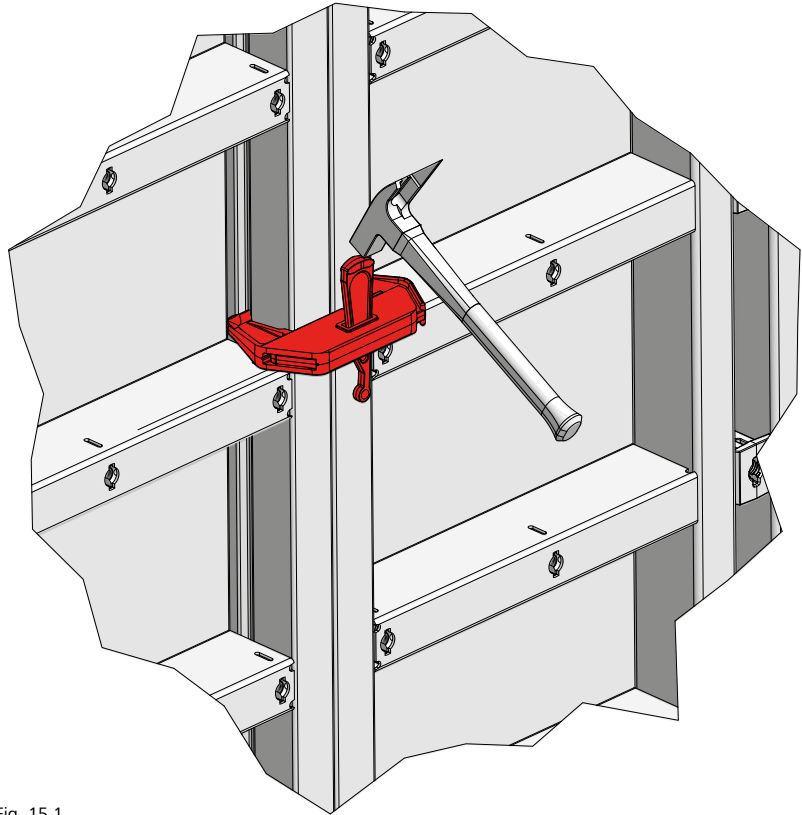


Fig. 15.1

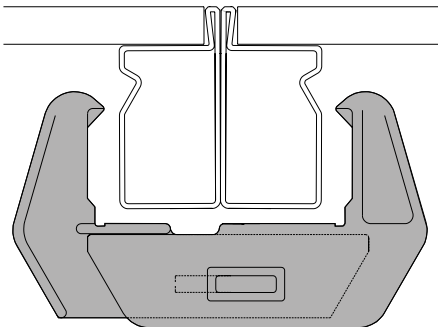


Fig. 15.2

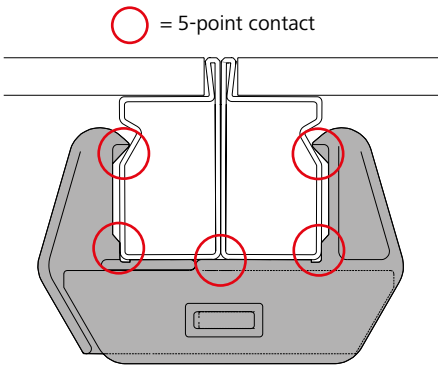


Fig. 15.3

= 5-point contact

Description	Ref. No.
M assembly lock	29-400-71

Tying methods

The Mammut XT allows three different tying methods:

- Single-sided tying with XT tie rod DW 20 and plastic tube (Fig. 16.1)
- Single-sided tying with XT taper tie 20 or 23 (Fig. 16.2) without plastic tube
- Two-sided tying with DW 20 tie rod and plastic tube (Fig. 16.3)

The max. load is 160 kN for all three types of tie rod.

Attention

Unused tie holes must always be closed with plug D35/38 or alternatively with XT sealing cone with a pressed-on plug D20 (see page XT-18).

Single-sided tying with XT tie rod DW 20 and plastic tube

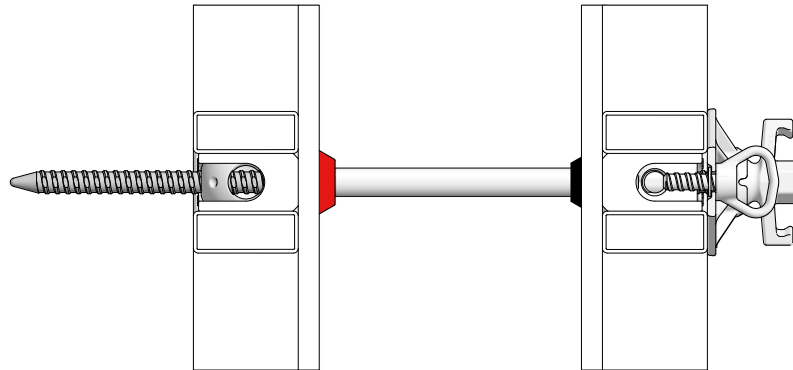


Fig. 16.1

Single-sided tying with XT taper tie 20 or 23 without plastic tube

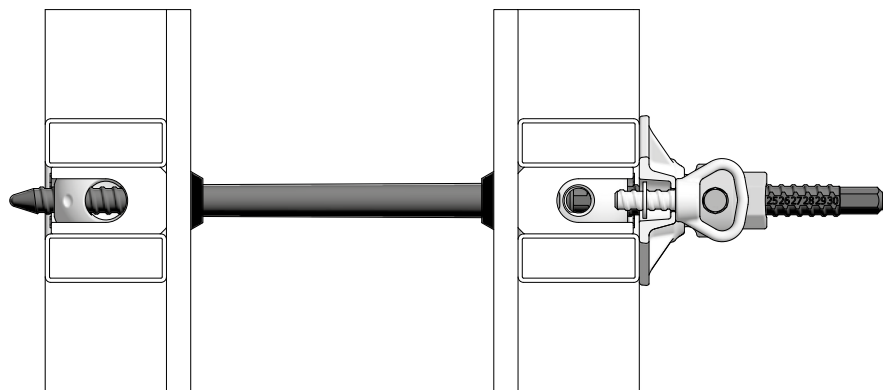


Fig. 16.2

Two-sided tying DW 20 and plastic tube

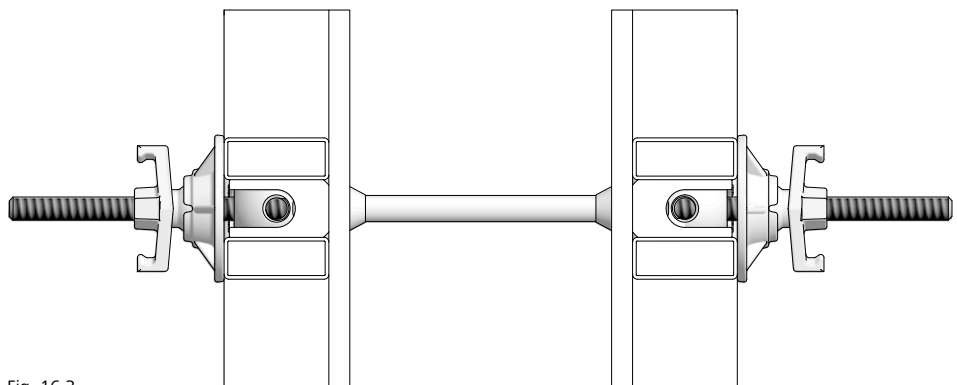


Fig. 16.3

Description	Ref. No.
XT tie rod DW 20/75.....	23-154-35
XT tie rod DW 20/120.....	23-154-40
Plastic tube D23/200.....	29-902-31
Plastic tube D23/18.....	29-902-03
Plastic tube D23/23.....	29-902-04
Plastic tube D23/28.....	29-902-05
Plastic tube D23/33.....	29-902-06
XT taper tie 20/15-25	23-154-10
XT taper tie 20/20-30	23-154-15
XT taper tie 20/35-45	23-154-20
XT taper tie 23/15-25	23-154-60
XT taper tie 23/20-30	23-154-65
XT taper tie 23/35-45	23-154-70
XT taper tie 23/45-55	23-154-75
XT taper tie 23/60-70	23-154-80
XT sealing cone 5 AL20	29-902-34
XT sealing cone 10 AL20	29-902-35
XT cone DW 20	29-902-37
Tie rod DW 20/120	29-900-97
Articulated flange nut 20/140	29-900-05
Plug D35/38	29-902-71

The combination tie hole

The combination tie hole (Fig. 17.1) is a rotating attachment point for XT tie rods DW, XT taper ties and tie rods DW.

It is recessed and firmly integrated between the centre profiles of the panel (Fig. 17.1).

Depending on the tying method selected (Table 17.6 and page XT-16), the sphere of the combination tie hole can be rotated by 90° to set it to either a conical anchor sleeve (Fig. 17.4) or a DW 20 thread (Fig. 17.5).

Setting it to the DW thread (Fig. 17.5 and Table 17.6) replaces the articulated flange nut on the formwork wall that is installed first (initial formwork) and allows single-sided tying.

The anchor sleeve (Fig. 17.4 and Table 17.6) is preset on the initial-formwork side for two-sided tying.

The combination tie hole is set using the XT lever (Figures 17.2 and 17.3).

Attention

As far as possible, tie rods are to be placed in every combination tie hole. In some cases tie rods can be replaced, see pages XT-71 and -72.

The karabiner hook on the XT lever is for storage purposes only and is not suitable for climbing.

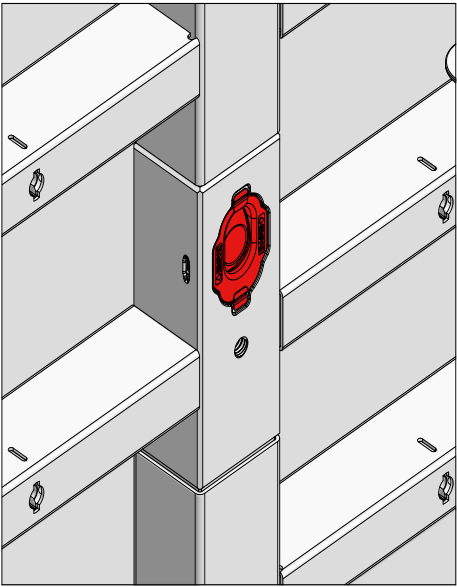


Fig. 17.1

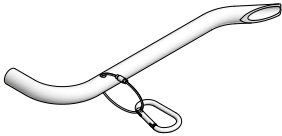


Fig. 17.2

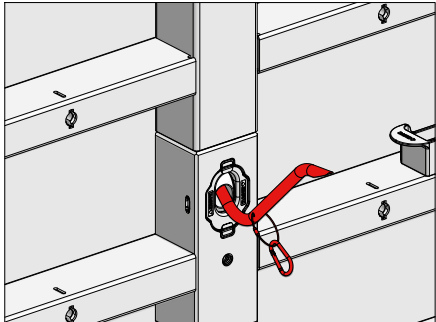


Fig. 17.3

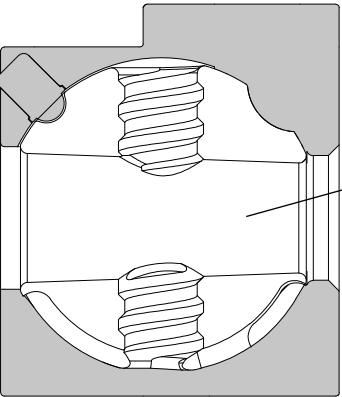


Fig. 17.4

Anchor sleeve

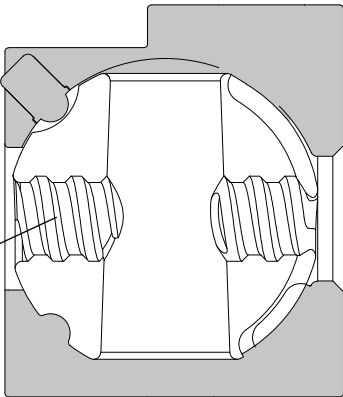


Fig. 17.5

Thread

Tying method	Initial formwork	Final formwork
Single-sided with XT tie rod DW 20 and plastic tube	Thread	Anchor sleeve
Single-sided with XT taper tie 20 or 23 without plastic tube	Thread	Anchor sleeve
Two-sided with DW tie rod and plastic tube	Anchor sleeve	Anchor sleeve

Table 17.6

Description	Ref. No.
XT combi lever.....	23-154-90

Sealing the combination tie hole

Various cones are available to seal the combination tie hole on the facing side.

The XT sealing cone 5 AL20 is used for single-sided tying (Fig. 18.1).

All XT panels are delivered with pre-assembled XT sealing cone 5 AL20 .

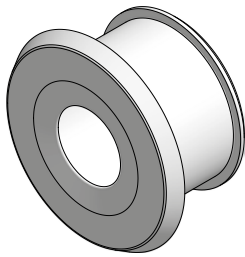


Fig. 18.1

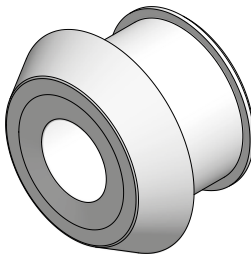


Fig. 18.2

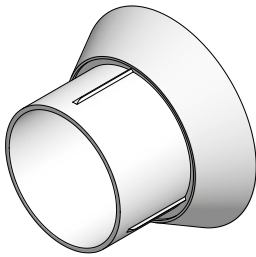


Fig. 18.3

If a clearly visible shadow gap is required, the XT sealing cone 10 AL20 (Fig. 18.2) is used for single-sided tying.

If tying is performed from two sides with DW tie rod and plastic tube, the cone for plastic tube D32 (Fig. 18.3) is to be used.

The same cone is used on the initial- and the final-formwork sides.

Tying method	XT sealing cone 5 AL20	XT sealing cone 10 AL20	Cone for plastic tube D32
Single-sided with XT tie rod DW 20 and plastic tube	Yes	Yes	No
Single-sided with XT taper tie 20 or 23 without plastic tube	Yes	Yes	No
Two-sided with DW tie rod and plastic tube	No	No	Yes

Table 18.4

To close unused combination tie holes, e.g. in the corner area, the plug D35/38 or alternatively the XT sealing cone with pressed-on plug D20 can be used (Fig. 18.5).

The XT sealing cone can be easily removed from the XT formwork panel without causing damage using the XT lever.

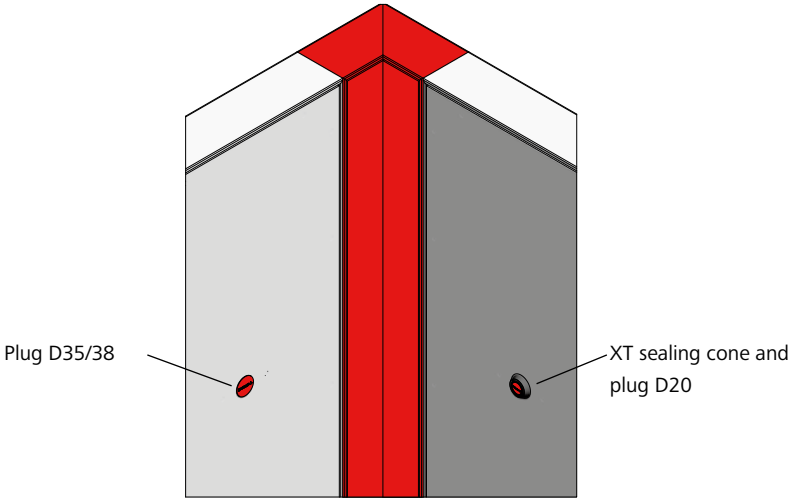


Fig. 18.5

Description	Ref. No.
XT sealing cone 5 AL20	29-902-34
XT sealing cone 10 AL20	29-902-35
Cone for plastic tube D32/10.	29-902-55
Plug D35/38	29-902-71
Plug D20, red.....	29-902-63

Single-sided tying with XT tie rod DW 20 and plastic tube

The XT tie rod DW 20 is available in various lengths for different wall thicknesses.

XT tie rod:

- DW 20/75 for wall thickness up to 40 cm
- DW 20/120 for wall thickness up to 85 cm

The wall thickness is determined by the length of the plastic tube. The plastic tube must be 20 mm shorter than the desired wall thickness (Fig. 19.2).

Plastic tubes D23 are available in the corresponding lengths for wall thicknesses 20, 25, 30 and 35 cm (Table 19.3).

Only the plastic tube D23/200 can be used.

When tying Mammut XT formwork on one side only using DW 20 tie rods (Fig. 19.1) and plastic tubes, the combination tie holes in the initial-formwork panels are set to the threaded position and all other panels are set to the anchor sleeve position (Fig. 19.2 and Table 1717.6).

Seal all tie holes with the XT sealing cone (Fig. 19.2 and page XT-18).

To correctly position the plastic tube, press the XT cone DW 20 on to the XT sealing cone on the initial-formwork side.

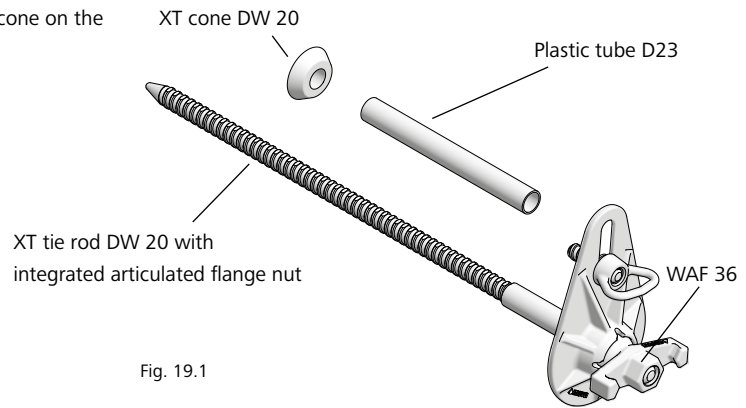


Fig. 19.1

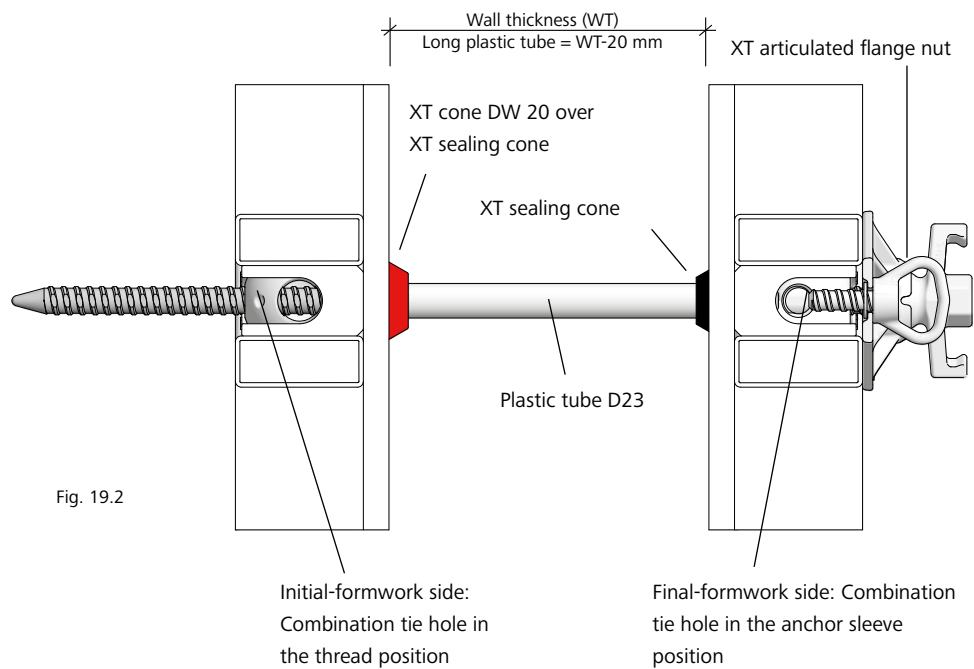


Fig. 19.2

Pre-cut plastic tube	Wall thickness (cm)
D23/18	20
D23/23	25
D23/28	30
D23/33	35

Table 19.3

Description	Ref. No.
XT tie rod DW 20/75.....	23-154-35
XT tie rod DW 20/120.....	23-154-40
Plastic tube D23/200.....	29-902-31
Plastic tube D23/18.....	29-902-03
Plastic tube D23/23.....	29-902-04
Plastic tube D23/28.....	29-902-05
Plastic tube D23/33.....	29-902-06
XT sealing cone 5 AL20	29-902-34
XT sealing cone 10 AL20	29-902-35
XT cone DW 20	29-902-37

Single-sided tying with XT tie rod DW 20 and plastic tube

Assembly

Before pouring:

1. Press XT cone DW 20 onto the XT sealing cone on the initial-formwork panel (Fig. 20.1, steps 1. to 3).

2. Place initial-formwork panel (Fig. 20.1 and XT-4 and -5) and carry out boxout work (Fig. 20.2).

3. Place final-formwork panel (Fig. 20.3).

4. Install plastic tube D23 on the XT tie rod DW 20. The length of the plastic tube depends on the wall thickness (see page XT-19).

5. Screw the XT tie rod DW 20 through the combination tie hole of the final-formwork side into the combination tie hole of the initial-formwork panel (Fig. 20.4) using the 36 mm ratchet spanner. An articulated flange nut is not required on the initial-formwork side.

6. Secure the XT tie rod DW 20 tightly by hand to the multi-function nut of the formwork panel using the fixation screw integrated into the XT articulated flange nut.

Disassembly

After pouring:

7. To strip the formwork, undo the fixation screw on the XT tie rod DW 20 and screw the tie rod out of the combination tie hole of the initial-formwork panel using the 36 mm ratchet spanner.

Notes

→ Correct set-up of the formwork to the desired wall thickness is facilitated by using a stop or a mark on the ground which allows the inside formwork to be positioned exactly.

→ The XT tie rod DW can be screwed in or out using the flange nut ratchet spanner. The width across flats is 36.

→ When stripping, ensure that the XT panel has been completely separated from the concrete before lifting it with the crane.

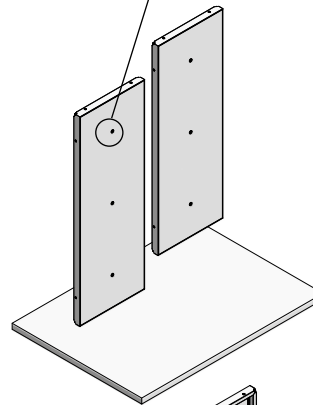
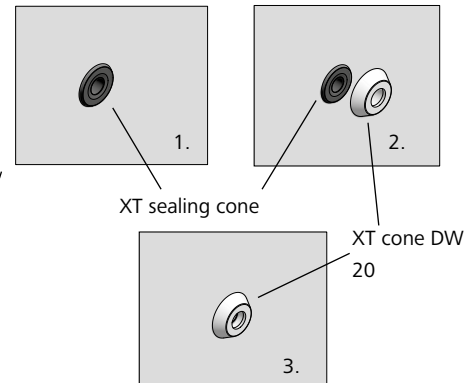


Fig. 20.1

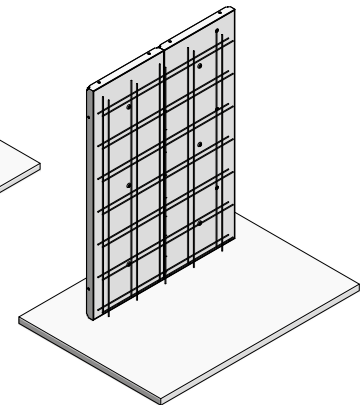


Fig. 20.2

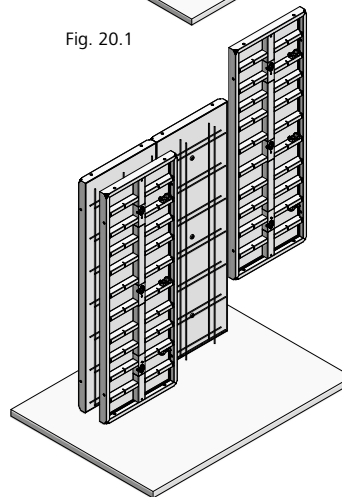


Fig. 20.3

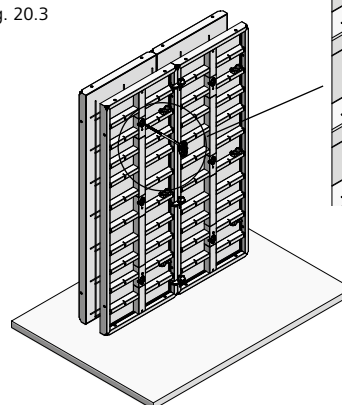
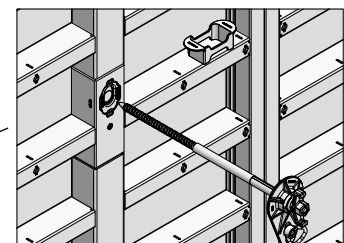


Fig. 20.4



Description	Ref. No.
XT tie rod DW 20/75.....	23-154-35
XT tie rod DW 20/120.....	23-154-40
Plastic tube D23/200.....	29-902-31
Plastic tube D23/18.....	29-902-03
Plastic tube D23/23.....	29-902-04
Plastic tube D23/28.....	29-902-05
Plastic tube D23/33.....	29-902-06
XT sealing cone 5 AL20	29-902-34
XT sealing cone 10 AL20	29-902-35
XT cone DW 20	29-902-37
Spanner size 36	29-800-15

Single-sided tying with XT taper tie 20

The XT taper tie 20 is available in various lengths for different wall thicknesses.

XT taper tie 20:

- 15–25 cm
- 20–30 cm
- 35–45 cm

It can be set for different wall thicknesses in 1 cm increments using spacers. The desired wall thickness can be read off the spacers (see page XT-22).

When tying Mammut XT formwork on one side only using XT taper ties 20, the combination tie holes in the panels of the initial-formwork panel are set to the threaded position and all other panels are set to the anchor sleeve position (Fig 21.2 and page XT-17).

The XT taper tie 20 can be screwed in or out using the XT taper tie ratchet spanner. The width across flats is 17.

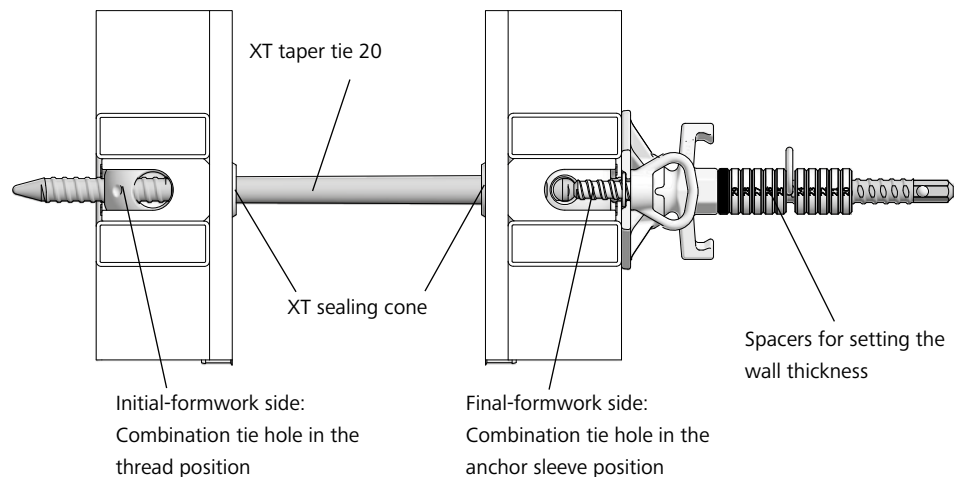
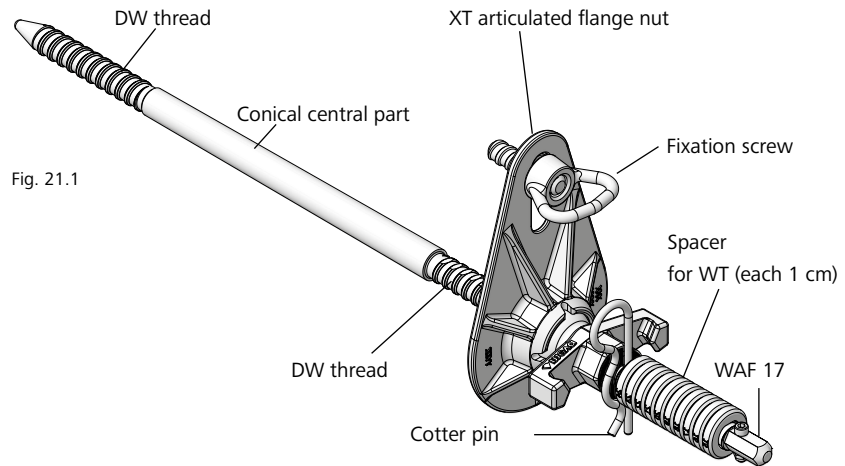


Fig. 21.2

Description	Ref. No.
XT sealing cone 5 AL20	29-902-34
XT sealing cone 10 AL20	29-902-35
XT taper tie 20/15-25	23-154-10
XT taper tie 20/20-30	23-154-15
XT taper tie 20/35-45	23-154-20
XT taper tie ratchet spanner set	29-800-25

Single-sided tying with XT taper tie 20

To set the wall thickness, remove the cotter pin from the XT taper tie 20 and install the required number of spacers in front of the cotter pin hole (Table 22.3). Each spacer is 1 cm thick. The desired wall thickness can be read off the spacer next to the cotter pin.

- Examples:
- Desired wall thickness = 35 cm:
XT taper tie 20/35-45, all spacers for WT in front of the cotter pin. (Fig. 22.1 and Table 22.3)
 - Desired wall thickness = 25 cm:
XT taper tie 20/20-30, spacer no. 25 in front of the cotter pin (Fig. 22.2 and Table 22.3)

Note
A coating of Divinol wax must be applied to the XT taper tie before and after each use.

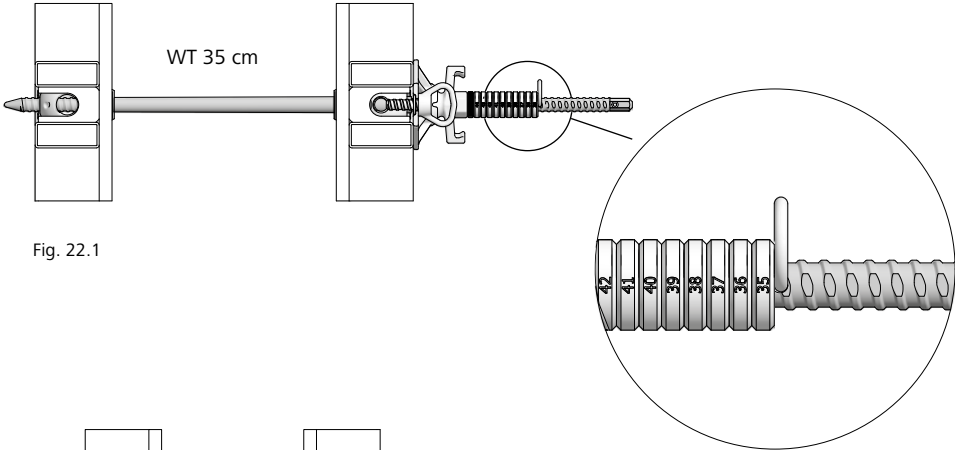


Fig. 22.1

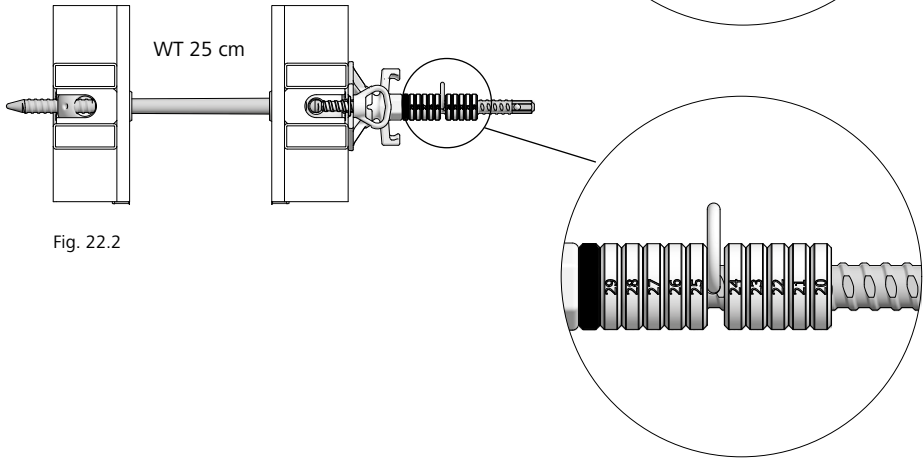


Fig. 22.2

Wall thickness (WT) in cm	XT taper tie 20	Spacers in front of the hole
15	15-25	11
20	(15-25) 20-30	(6) 11
24	(15-25) 20-30	(2) 7
25	(15-25) 20-30	(1) 6
30	20-30	1
35	35-45	11
40	35-45	6
45	35-45	1

Table 22.3

Description	Ref. No.
XT taper tie 20/15-25	23-154-10
XT taper tie 20/20-30	23-154-15
XT taper tie 20/35-45	23-154-20
Divinol wax.....	29-203-30

Single-sided tying with XT taper tie 23

The XT taper tie 23 (Fig. 23.1) is available in various lengths for different wall thicknesses.

XT taper tie 23:

- 15–25 cm
- 20–30 cm
- 35–45 cm
- 45–55 cm
- 60–70 cm

It can be set for different wall thicknesses in 0.5 cm increments on the XT articulated flange nut using the two adjustment screws.

When tying Mammut XT formwork on one side only using XT taper ties 23, the combination tie holes in the panels of the initial-formwork panel are set to the threaded position and all other panels are set to the anchor sleeve position (see page XT-17).

The XT taper tie 23 can be screwed in or out and the adjustment screw for the wall thickness can be undone and tightened using the XT taper tie ratchet spanner. The width across flats is 19.

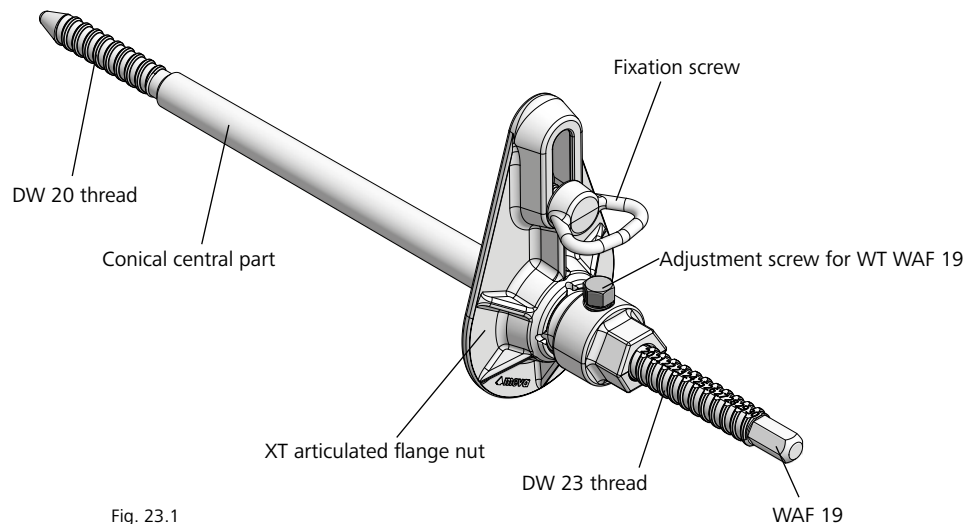


Fig. 23.1

Description	Ref. No.
XT sealing cone 5 AL20	29-902-34
XT sealing cone 10 AL20	29-902-35
XT taper tie 23/15-25	23-154-60
XT taper tie 23/20-30	23-154-65
XT taper tie 23/35-45	23-154-70
XT taper tie 23/45-55	23-154-75
XT taper tie 23/60-70	23-154-80
XT taper tie ratchet spanner set.....	29-800-25

Wall Formwork

Single-sided tying with XT taper tie 23

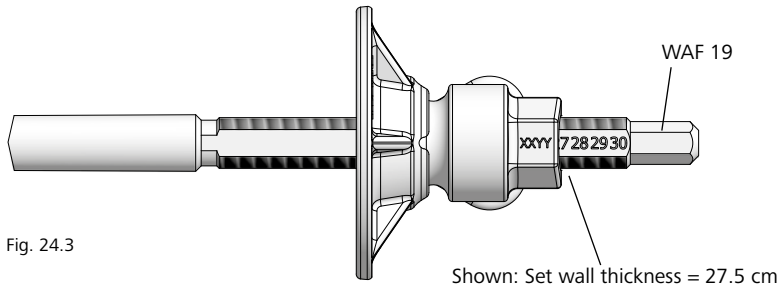
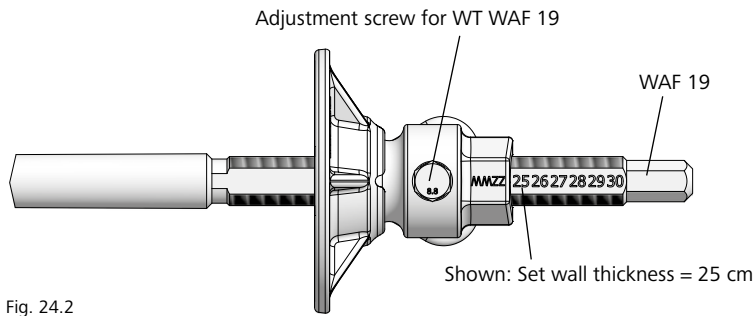
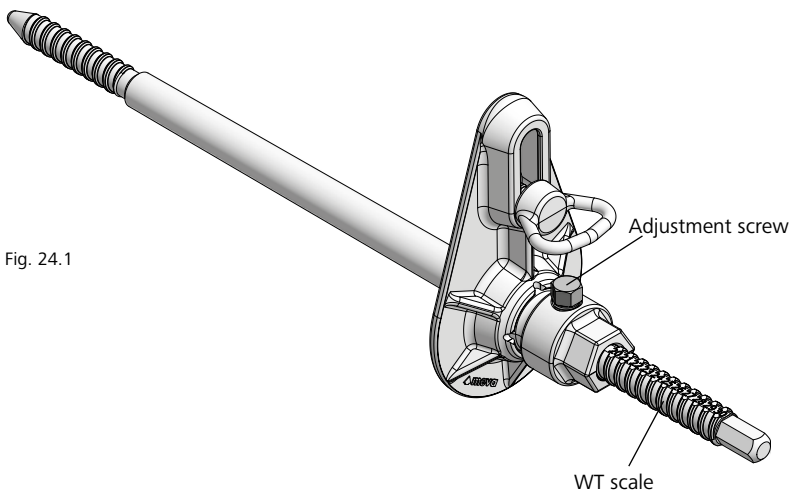
The XT taper tie 23 (Fig. 24.1) has an adjustment screw for wall thicknesses in 0.5 cm increments:

Before setting the wall thickness, the adjustment screw (WAF 19) must be loosened.

To set wall thicknesses in whole centimetres, screw on the XT articulated flange nut until the desired wall thickness can be read off the scale at the end of the shaft (Fig. 24.2). Then tighten the screw with a ratchet spanner or spanner.

For half centimetres the WT scale must be half visible (Fig. 24.3). The adjustment screw is located on the rear of the shaft. Then tighten the screw with a ratchet spanner or spanner.

A coating of Divinol wax must be applied to the XT taper tie before and after each use.



Description	Ref. No.
XT taper tie 23/15-25	23-154-60
XT taper tie 23/20-30	23-154-65
XT taper tie 23/35-45	23-154-70
XT taper tie 23/45-55	23-154-75
XT taper tie 23/60-70	23-154-80
Divinol wax.....	29-203-30

Single-sided tying with XT taper tie 20 or 23

Assembly

Before pouring:

1. Place initial-formwork panel (Fig. 25.1 and XT-4 and -5) and carry out boxout work (Fig. 25.2).

2. Place final-formwork panel (Fig. 25.3).

3. Prepare the XT taper tie 20 or 23 for the desired wall thickness (see pages XT-22 and -24) and apply a coating of wax.

4. Push the XT taper tie through the combination tie hole of the final-formwork side and screw it into the combination tie hole of the initial-formwork panel using the XT taper tie ratchet spanner (WAF 17 or 19) (Fig. 25.4). An articulated flange nut on the initial-formwork side and a plastic tube are not required.

5. Secure the XT taper tie tightly by hand to the multi-function nut of the formwork panel using the fixation screw integrated into the XT articulated flange nut.

Disassembly

After pouring:

6. To strip the formwork, undo the fixation screw on the XT taper tie and screw the tie rod out of the combination tie hole of the initial-formwork panel using the XT taper tie ratchet spanner (WAF 17 or 19).

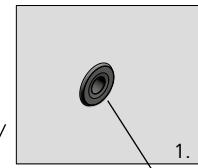
Note

→ Correct set-up of the formwork to the desired wall thickness is facilitated by using a stop or a mark on the ground which allows the inside formwork to be positioned exactly.

→ The XT taper tie can be screwed in or out using the XT taper tie ratchet spanner. The width across flats is 17 mm (XT taper tie 20) or 19 mm (XT taper tie 23). When screwing the taper tie in, a tightening torque of 200 Nm should not be exceeded.

→ We recommend slackening the articulated flange nut of the XT taper tie approximately 24 hours after pouring the concrete and screwing out the tie rod by approximately half a turn.

→ When stripping, ensure that the XT panel has been completely separated from the concrete before lifting it with the crane.



XT sealing cone

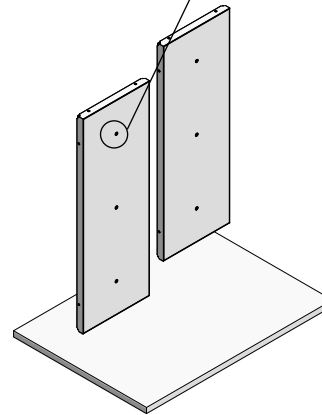


Fig. 25.1

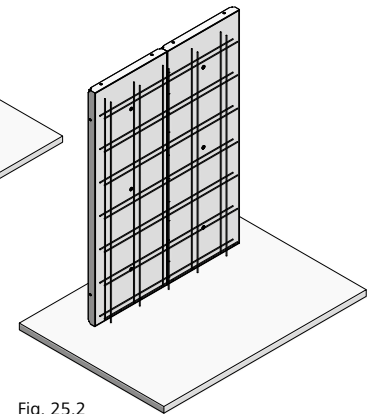


Fig. 25.2

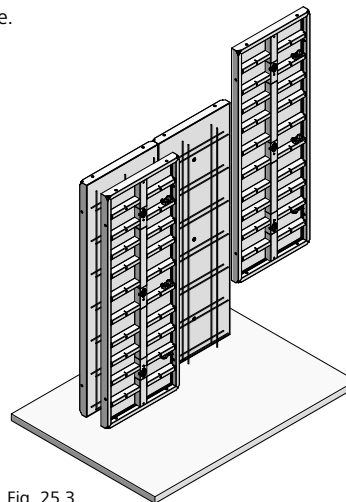


Fig. 25.3

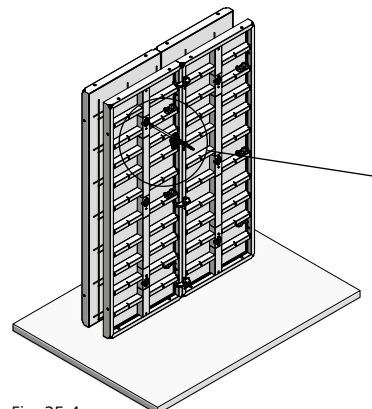
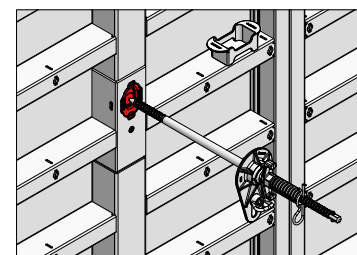


Fig. 25.4



Description	Ref. No.
XT sealing cone 5 AL20	29-902-34
XT sealing cone 10 AL20	29-902-35
XT taper tie 20/15-25	23-154-10
XT taper tie 20/20-30	23-154-15
XT taper tie 20/35-45	23-154-20
XT taper tie 23/15-25	23-154-60
XT taper tie 23/20-30	23-154-65
XT taper tie 23/35-45	23-154-70
XT taper tie 23/45-55	23-154-75
XT taper tie 23/60-70	23-154-80
XT taper tie ratchet spanner set	29-800-25
Divinol wax	29-203-30

Two-sided tying with DW tie rod and plastic tube

When tying Mammut XT formwork on both sides using DW tie rods and plastic tubes, all combination tie holes in the panels are set to the anchor sleeve position (Fig 26.1).

The Mammut XT is designed for use with the tie rod DW 20.

Note

The XT tie rod DW 20 or the XT taper tie 20 or 23 can also be used in the combination tie hole for two-sided tying with plastic tube.

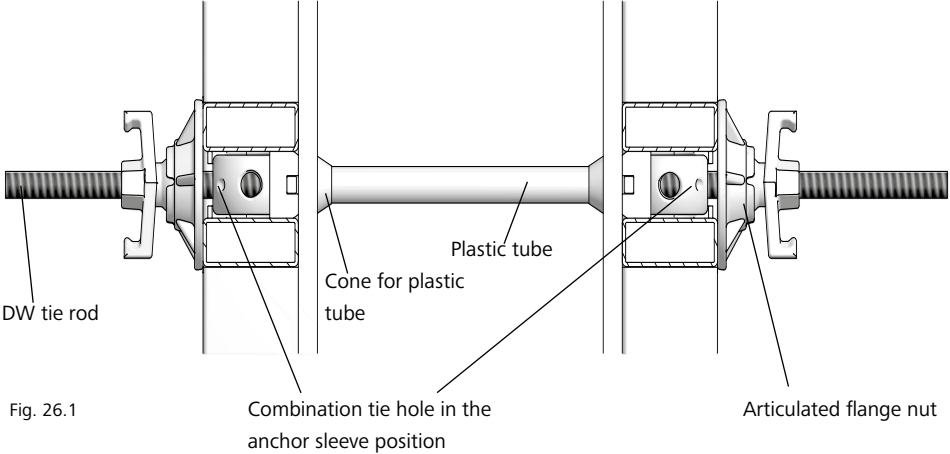


Fig. 26.1

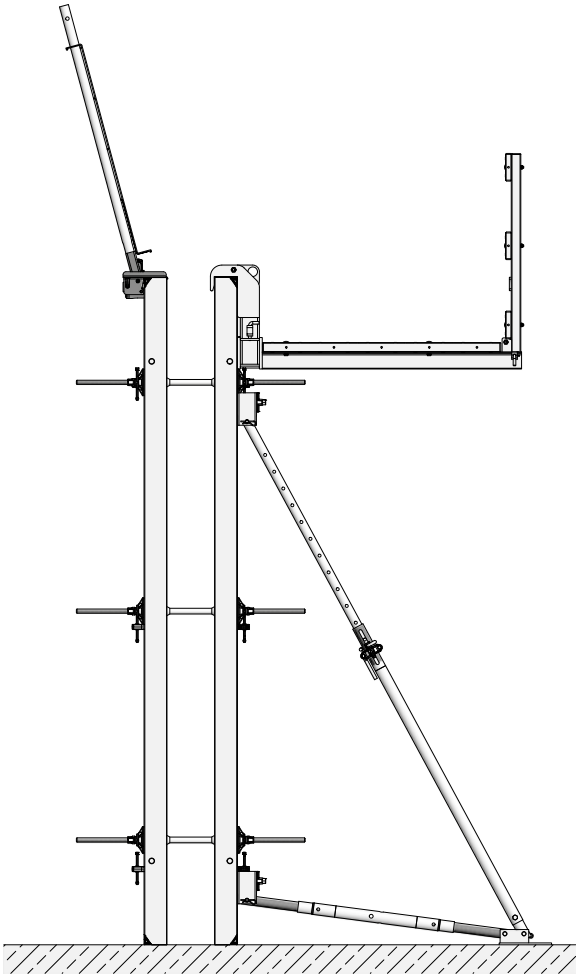


Fig. 26.2

Description	Ref. No.
Tie rod DW 20/120	29-900-97
Articulated flange nut 20/140	29-900-05
Plastic tube D32/200.....	29-902-28
Cone for plastic tube D32/10.	29-902-55

Rules for concrete pouring and rate of placing

The maximum permissible fresh-concrete pressure for Mammut XT is **100 kN/m²** (when using tie rods with a permissible working load of 160 kN).

Rules for concrete pouring

→ For the rate of placing of walls higher than 4.00 m refer to Table 27.1.

→ According to DIN 4235, concrete should be placed in layers whose thickness can vary from 0.50 m bis 1.00 m.

→ Concrete must not be placed above heights of 1.50 m (or higher) in free fall.

→ When vibrating the concrete, which is done layer by layer, the vibrator must not penetrate more than 50 cm into the layer below.

→ A final vibrating step over the overall concrete height is not recommended. It does not provide any advantage, since concrete that has been vibrated once cannot be compacted further. This may result in water bubbles (shrinkage cavities) on the concrete surface.

Rate of placing

The permissible rate of placing can be precisely determined according to DIN 18218:2010-01 by referring to Tables 27.1 and 27.2 or using MEVA's online calculation programme available on the MEVA website.

This and other digital aids are available in the download area at www.meva.net and in the app MEVA me for iOS and Android.

Note that you cannot use Table 27.1 unless you know the end of setting of the concrete, t_E . This value can be determined on-site using MEVA's ultrasonic SolidCheck measuring device or knead-bag tests as described in DIN 18218:2010-01. Or simply ask the concrete supplier for the concrete's end of setting.

Maximum rate of placing v_b (depending on the concrete's consistency and end of setting t_E)* in m/h					
Mammut XT (DW 20 / XT tie rod DW 20 / XT taper tie 20 and 23)		$t_E = 5$ h	$t_E = 7$ h	$t_E = 10$ h	$t_E = 15$ h
Consistency range	F3	5.64	4.72	3.72	2.63
	F4	4.71	3.46	2.36	1.38
	F5	2.40	1.71	1.20	0.80
	F6	1.89	1.35	0.95	0.63
	SCC	2.18	1.56	1.09	0.73

Table 27.1

* According to DIN 18218:2010-01 (fresh-concrete pressure on vertical formwork)

t_E = End of setting of the concrete

v_b = Maximum rate of placing

Specific values of the XT taper ties 20 and 23

XT taper tie	20	23
d_1 thread tie rod tip [mm]	19.6	19.8
d_2 thread tie rod tip [mm]	22.0	22.4
d_1 thread tie rod end [mm]	19.6	23.4
d_2 thread tie rod end [mm]	22.0	26.0
d_1 cone	22.5	26.0
d_2 cone	25.5	29.0
Nominal cross-section [mm ²]	301.7	307.9
Permissible working load according to DIN 18216 [kN]	160	160
Tie rod elongation when using the permissible working load [mm/m]	3	3

Table 27.2

Specific values of tie rods DW 15 and DW 20

DW tie rod	15	20
d_{21} [mm]	15	20
d_{22} [mm]	17	22.4
Nominal cross-section [mm ²]	177	314
Permissible working load according to DIN 18216 [kN]	90	160
Tie rod elongation when using the permissible working load [mm/m]	2.5	2.35

Table 27.3

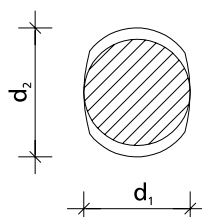


Fig27.4 Diameter thread

Flatness of surface

The permissible deflection of formwork parts is defined in DIN 18202 (flatness tolerances), Table 3, lines 5 to 7 (Table 28.1). Here, the maximum permissible deflection is defined in relation to the distance between the measuring points. The permissible fresh-concrete pressure that is in line with the flatness tolerances as defined in DIN 18202, Table 3, line 7 is 100 kN/m² for full load.

DIN 18202, Table 3

Column	1	2	3	4	5	6
		Distances as limiting values in mm for distances between measuring points in m				
Line	Reference	0.1	1*	4*	10*	15*
5	Unexposed walls and undersides of slabs	5	10	15	25	30
6	Exposed walls and undersides of slabs, e.g. plastered walls, panelling, suspended ceilings	3	5	10	20	25
7	Like line 6, but with stricter requirements	2	3	8	15	20

Table 28.1

* Intermediate values can be found in Fig. 28.2. Round up values found to full mm.

The measuring lath is placed on the highest protruding points of the surface and the deflection is measured at the deepest point in-between.

The distance between measuring points corresponds to the distance between the highest protruding points.

Flatness tolerances of walls and undersides of slabs
(according to DIN 18202, Table 3)

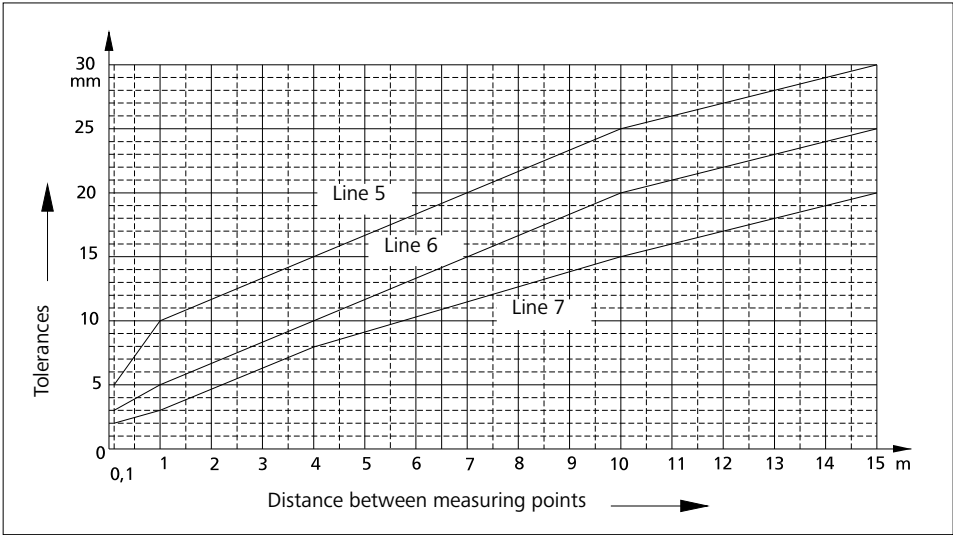


Fig. 28.2

Attachment of accessories

All panels are provided with multi-function profiles with welded-in Dywidag-threaded nuts (Figures 29.1, 29.5 and 29.6).

Walkway brackets are provided with integrated self-locking pins (Fig. 29.2) and are mounted on the multi-function profiles and secured with a flange screw 18.

Formwork is set vertically using push-pull props attached to the panel with a flange screw 18 via the formwork-prop connector as shown in Fig. 29.4.

Alignment rails should be attached to the multi-function profiles with flange screws in order to stabilise ganged panels when lifting them by crane, bridge problem areas and brace and stabilise the fillers used to bridge gaps between the panels.

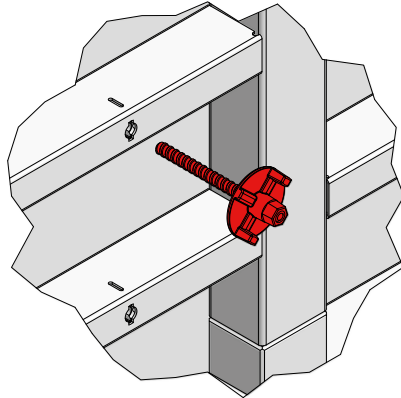


Fig. 29.1

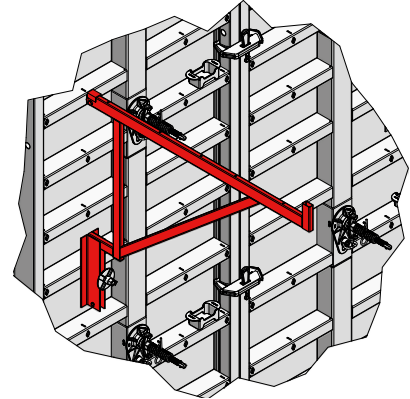


Fig. 29.2

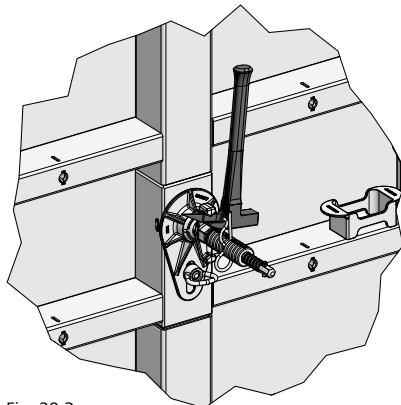


Fig. 29.3

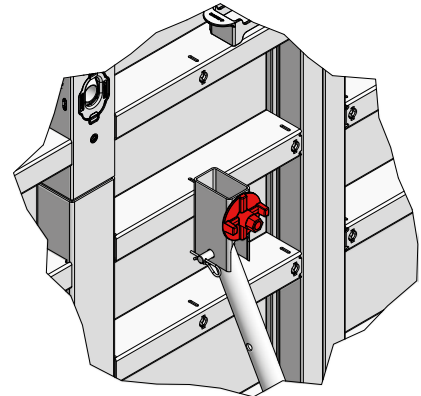


Fig. 29.4

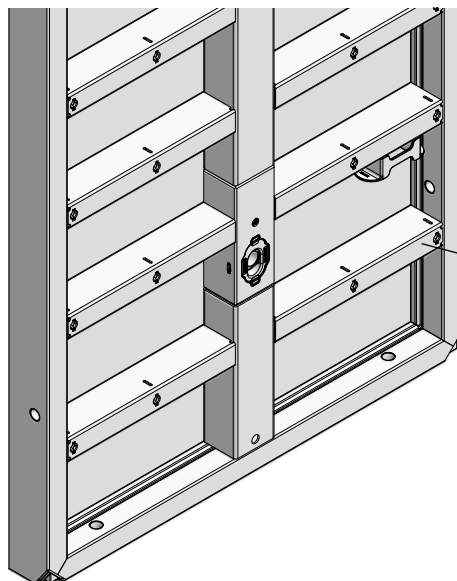


Fig. 29.5

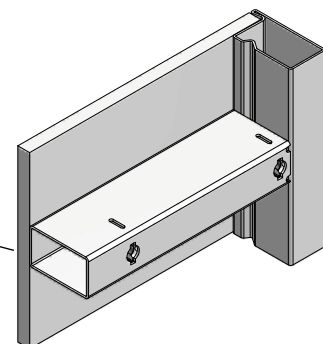


Fig. 29.6

Wall Formwork

Wall braces

A push-pull prop or the brace frame 250 with formwork-prop connector are attached to the panel's multi-function profile with flange screw 18 (pages XT-29 and -31).

The brace frame 250 is made up of the push-pull prop R 250, the brace SRL 120, two formwork-prop connectors and the double-jointed foot plate.

If push-pull props or brace frames are only used to align the formwork, we recommend a maximum spacing of 4.00 m. In order to withstand wind loads, refer to Table 30.1. For further applications contact MEVA.

Assumptions for Table 30.1

- Wind loads according to DIN EN 1991-1-4
- Wind zone 2, inland (mixed profile between terrain categories II and III)
- Impact pressure $q_p = 0.65 \text{ kN/m}^2$ (Table 30.2)
- Pressure coefficient used $c_p = 1.8$
- Exposure time factor $\psi = 0.7$
- Wind pressure $w = q_p \cdot c_p \cdot \psi$
- Formwork on upper edge of terrain
- Values are characteristic values

Wall braces	Formwork height h (m)							
	2.50	3.00	3.25	3.50	3.75	4.00	4.25	4.50
Push-pull prop	R250+ SRL120	R250+ SRL120	R250+ SRL120	R460+ SRL170	R460+ SRL170	R460+ SRL170	R460+ SRL170	R460+ SRL170
Permissible influence width e (m)	5.78	4.72	4.37	4.13	3.79	3.40	3.23	3.04
Prevailing brace load F_1 (kN)	5.95	5.57	5.64	5.95	5.65	4.93	5.07	5.02
Prevailing push-pull prop load F_2 (kN)	11.85	12.08	12.06	11.85	12.01	12.44	12.37	12.37
Lifting force V_{Wind} (kN/m)	1.88	2.32	2.49	2.58	2.84	3.27	3.41	3.62
Prevailing dowel force $V_{dowel 1}$ (kN)	14.16	14.25	14.25	14.17	14.21	14.38	14.34	14.35
Prevailing dowel force $H_{dowel 1}$ (kN)	11.85	11.61	11.62	11.85	11.64	11.15	11.24	11.22
a (m)*	0.275	0.38	0.375	0.275	0.375	0.658	0.625	0.665
b (m)**	1.31	1.54	1.68	1.89	1.97	1.95	2.12	2.24

Wall braces	Formwork height h (m)							
	4.75	5.00	6.00	6.50	7.00	7.50	8.25	9.00
Push-pull prop	R460+ SRL170	R460+ R250	R460+ R250	R630+ R250+ SRL170	R630+ R460+ SRL170	R630+ R460+ SRL170	Triplex+ R460+ SRL170	Triplex+ R460+ R250
Permissible influence width e (m)	2.79	2.38	2.03	2.68	2.41	2.50	1.81	2.02
Prevailing brace load F_1 (kN)	4.49	3.95	4.04	3.30	2.94	3.23	2.66	3.60
Prevailing push-pull prop load F_2 (kN)	12.75	11.73	11.96	13.48	12.80	11.70	12.85	11.96
Lifting force V_{Wind} (kN/m)	4.05	4.59	5.42	7.16	7.90	8.51	9.24	10.03
Prevailing dowel force $V_{dowel 1}$ (kN)	14.51	14.92	14.74	14.82	15.13	13.65	15.19	14.95
Prevailing dowel force $H_{dowel 1}$ (kN)	10.85	9.73	9.97	10.05	9.35	9.08	9.09	9.53
Prevailing push-pull prop load F_3 (kN)	-	-	-	8.42	8.97	12.60	6.30	10.73
Prevailing dowel force $V_{dowel 2}$ (kN)	-	-	-	8.47	11.35	15.98	5.45	9.29
Prevailing dowel force $H_{dowel 2}$ (kN)	-	-	-	4.21	4.48	6.28	3.15	5.35
a (m)*	0.923	1.25	1.40	3.28	3.78	4.19	4.20	4.75
b (m)**	2.23	2.19	2.68	1.89	1.69	1.93	2.36	2.48
c (m)***	-	-	-	1.05	1.15	1.69	0.92	1.75
d (m)****	-	-	-	3.17	3.40	3.37	4.19	4.14

Table 30.1

* Upper pivot point a, distance measured between top edge of formwork and attachment point of the upper formwork-prop connector

** Distance to the foot plate b, measured from the rear edge of the formwork to the attachment of the foot plate

*** Upper pivot point c, distance measured between top edge of formwork and attachment point of the upper formwork-prop connector of the individual push-pull prop

**** Distance to the foot plate d, measured from the rear edge of the formwork to the attachment of the foot plate of the individual push-pull prop

Wind impact pressure for buildings up to a height of 25 m:

Description	Ref. No.
Braces SRL	
SRL 120	29-108-80
SRL 170	29-108-90
Push-pull props R	
R 160	29-109-40
R 250	29-109-60
R 460	29-109-80
R 630	29-109-85
Formwork-prop connector	29-804-85
Brace frame 250 with formwork-prop connector	29-109-20
Flange screw 18	29-401-10
Double-jointed foot plate	29-402-32

Wind zone		Impact pressure q_p in kN/m^2 at a ground elevation within the limits		
		$h \leq 10 \text{ m}$	$10 \text{ m} < h \leq 18 \text{ m}$	$18 \text{ m} < h \leq 25 \text{ m}$
1	Inland	0.50	0.65	0.75
	Coast and island in Baltic Sea	0.65	0.80	0.90
2	Inland	0.85	1.00	1.10
	Coast and island in Baltic Sea	0.80	0.95	1.10
3	Inland	1.05	1.20	1.30
	Coast and island in Baltic Sea	0.95	1.15	1.30
4	Inland	1.25	1.40	1.55
	Coast of North Sea and Baltic Sea and island in Baltic Sea	1.40	-	-
	Island in North Sea	1.40	-	-

Table 30.2

Wall Formwork

Wall braces

Note

A restraint mechanism is required when the lifting force $F_A = 1.5 \times V_{\text{Wind}} - 0.9 \times G \times h > 0$.
 G = dead load of the formwork (including platforms)

For walls up to 6.00 m we recommend assembling a brace frame on-site consisting of the push-pull props R 460 and R 250. The required formwork-prop connectors and double-jointed foot plates must be ordered separately.

For formwork heights above 6.50 m a brace frame is assembled on-site consisting of push-pull prop R 630 and push-pull prop R 250 or R 460. Above a formwork height of 8.25 m the Triplex brace is also used. It is especially designed to brace and align high wall formwork (see Table 30.1).

Please observe the Triplex Technical Instruction Manual.

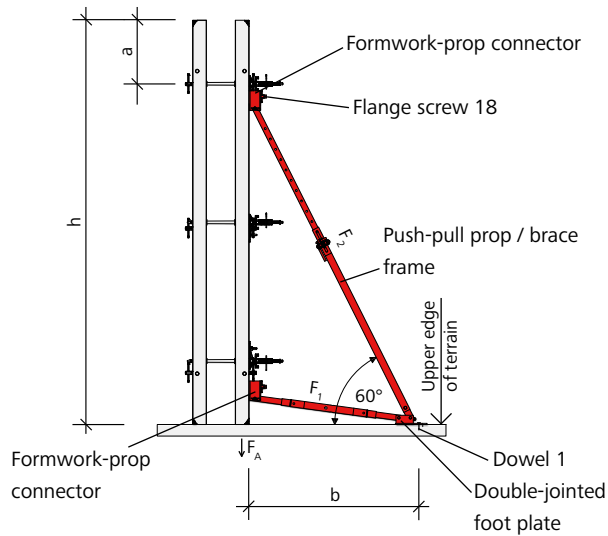


Fig. 31.1

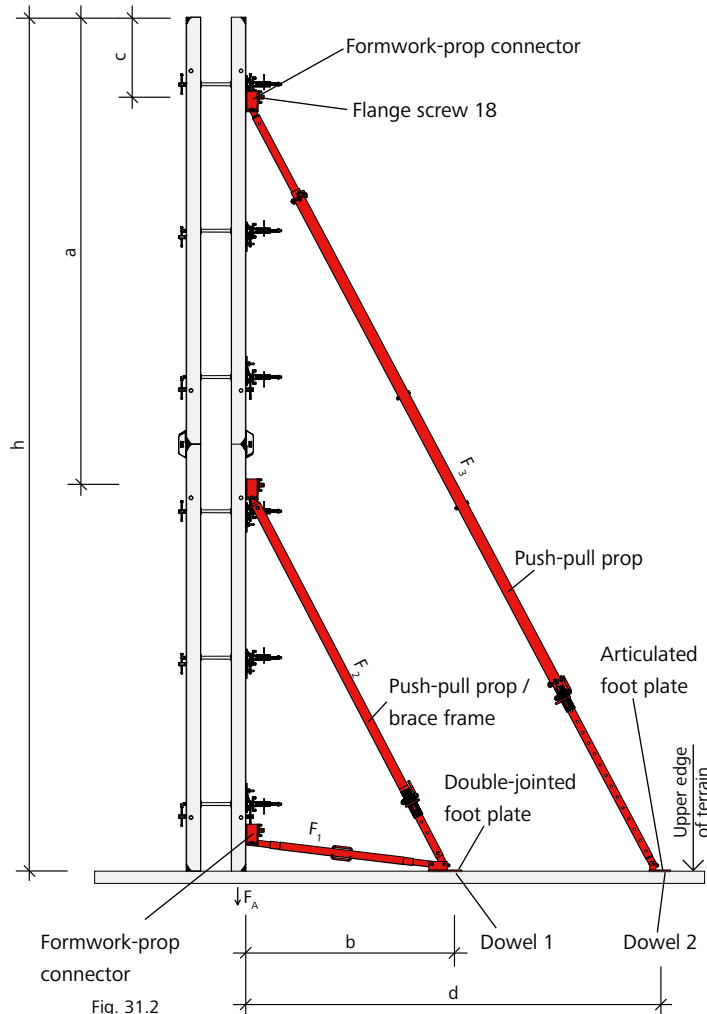


Fig. 31.2

Description	Ref. No.
Braces SRL	
SRL 120	29-108-80
SRL 170	29-108-90
Push-pull props R	
R 160	29-109-40
R 250	29-109-60
R 460	29-109-80
R 630	29-109-85
Formwork-prop connector	29-804-85
Brace frame 250 with formwork-prop connector	29-109-20
Flange screw 18	29-401-10
Double-jointed foot plate	29-402-32

Wall Formwork

Wall braces

The brace is attached to the double-jointed foot plate (Fig. 32.1) or the foot plate 73 (Fig. 32.2) using MEVA quick anchors or anchor bolts, for example.

The permissible influence width of the bracing (e) is reduced at the edge of the formwork as shown in Fig. 32.3.

→ e = permissible influence width (see Table XT-30.1)

→ The shoe plate 60 can be used to secure the Mammut XT panel to the ground (Fig. 32.4). It can be secured using a MEVA quick anchor or an anchor bolt.

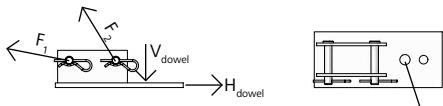


Fig. 32.1 Double-jointed foot plate

Attachment point for dowel/bolt, e.g. MEVA quick anchor, Fischer anchor bolt FAZ II 20/30 or equivalent

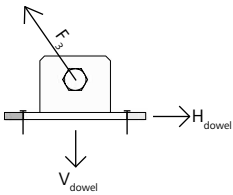


Fig. 32.2 Foot plate 73

Attachment points for dowel/bolt, e.g. MEVA quick anchor, Fischer anchor bolt FAZ II 20/30 or equivalent

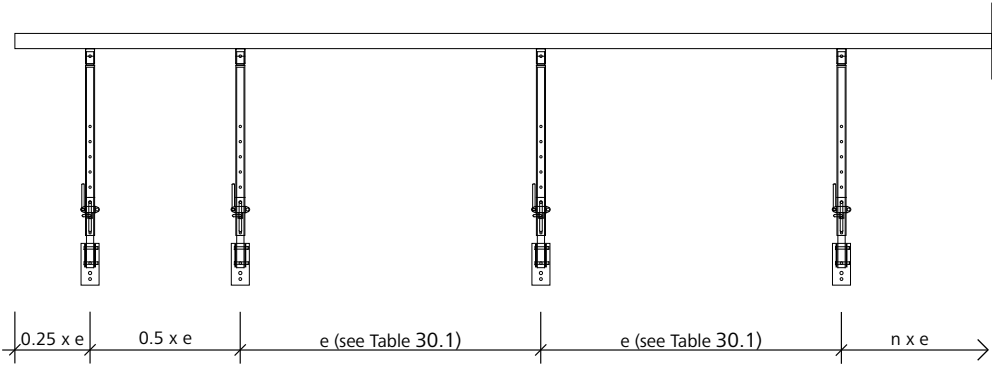
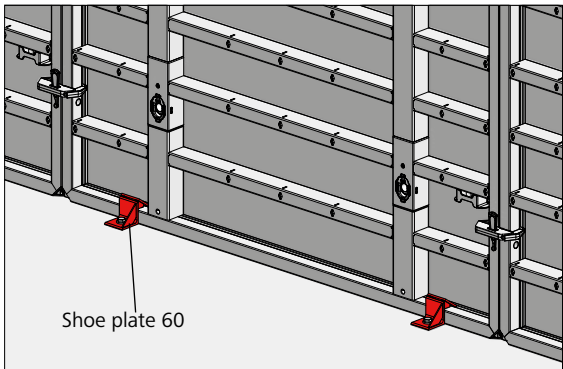


Fig. 32.3



Description	Ref. No.
Shoe plate 60	23-311-95
Spiral anchor DW 15/100.....	29-921-10

Wall Formwork

Workplaces

The fall height of workplaces must not exceed 2.00 m in accordance with DIN 12811-1.

According to DIN 12811-1 the design of the working scaffold must be as shown in Fig. 33.1. Note that this regulation is valid for Germany. Always observe the federal, state and local regulations of the country where the formwork is used.

Note

Minimum cross section of handrail and midrail: For a post spacing up to 2.00 m: 15 x 3 cm
 For a post spacing up to 3.00 m: 20 x 4 cm (Fig. 33.1).

We recommend the use of safety meshes. They are a quick and safe method to provide fall protection (Fig. 33.2).

Attention

When using our products, the federal, state and local codes and regulations must be observed.

Working scaffold according to DIN 12811-1, Part 1

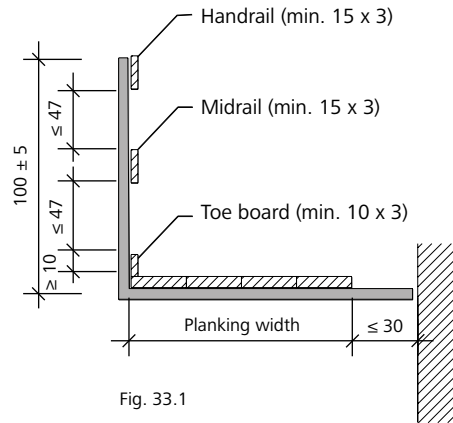


Fig. 33.1

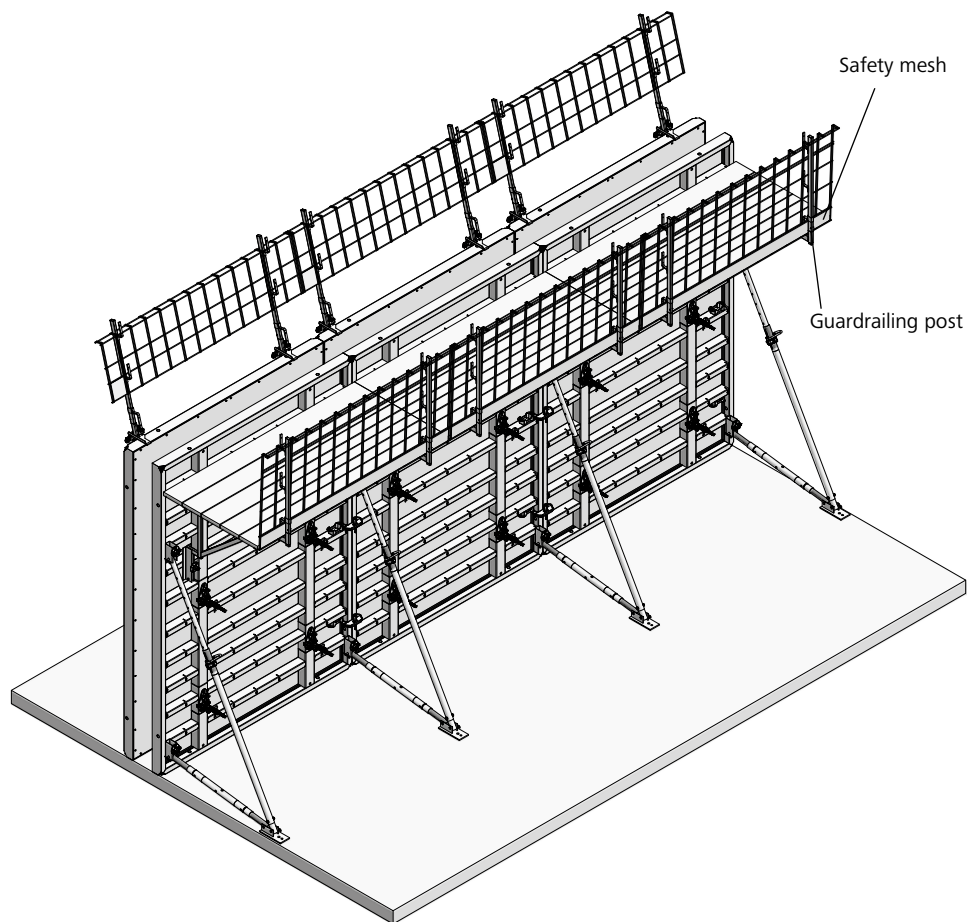


Fig. 33.2

Description	Ref. No.
Safety mesh 1100/2490.....	29-920-00
Safety mesh 600/2490.....	29-920-05

Workplaces – MEVA Integrated Safety

The system MIS – MEVA Integrated Safety is the all-in-one solution for a robust safety system that ensures safety at every construction stage.

The safety system (DIN EN 12811 and DIN EN 12812) with working platform, access ladder, rear railing, front railing, side railings, brace frames, platform extensions made of hot-dip galvanised steel and aluminium checkered sheet flooring is designed as a modular system. The well-thought-out product design increases the safety on the platform and makes it possible to work comfortably and efficiently.

As an access solution for Mammut XT with two platform widths (250 cm and 125 cm), MIS can be used up to a formwork height of 10.50 m. The foldable platforms can be height-adjusted due to the play in the linkage and can remain permanently attached to the formwork panel if required. Mammut XT wall formwork and working platforms can be relocated as a fixed unit.

Tie rods and accessories can be used safely at all heights. Integrated assembly lock holders and tie rod fixtures on the railing enable efficient work routines.

The units are stackable for space-saving storage and transport and thus provide for simplified construction site logistics.

The MIS safety system can be retrofitted to the Mammut XT wall formwork system at any time.

Please observe the MIS – MEVA Integrated Safety Technical Instruction Manual.

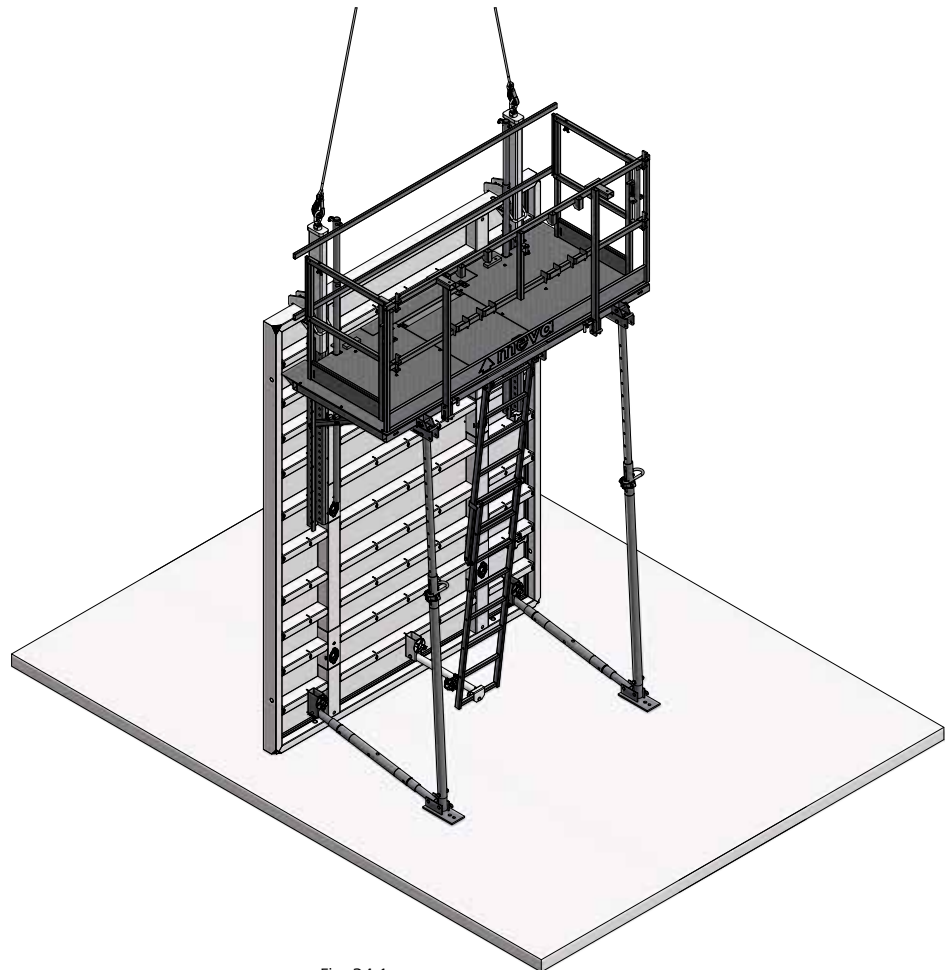


Fig. 34.1

Workplaces – Folding access platform BKB 125

The folding access platform BKB 125 with folding guardrailing provides safe access and a 125 cm wide working platform (Fig 35.1). It enables quick and safe installation of working scaffolds.

The 48 mm thick planks have a rough surface and a metal lining at the edges.

Its length of 235 cm allows the BKB 125/235 to be easily transported, as it fits crosswise on any truck. The stacking height is only 17 cm and the permissible load is 2 kN/m² (200 kg/m²).

The guardrailing can be set to an angle of 90° or 105° (Fig. 35.2). The BKB 125 side railing is mounted to the platform with two flange screws 18.

Attention

Do not crane formwork units when the working platform is attached to the formwork.

To relocate the individual platforms with a crane so that they are all at the same height, we recommend adjusting the length of the chains on the crane sling.

When using our products, the federal, state and local codes and regulations must be observed.

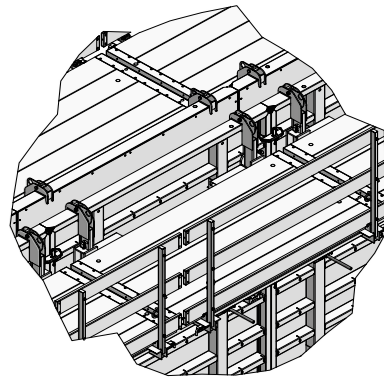


Fig. 35.1

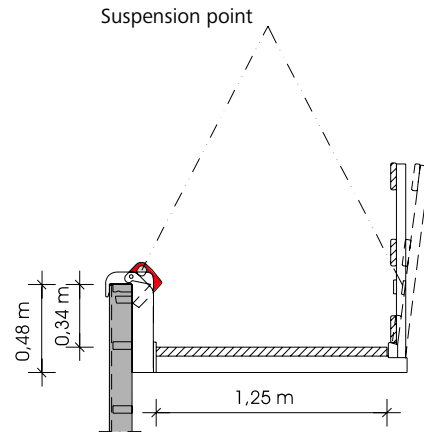


Fig. 35.2

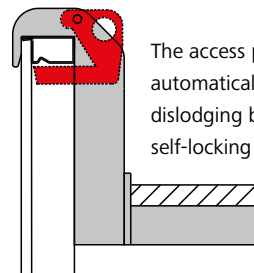


Fig. 35.3

The access platform is automatically secured against dislodging by the integrated self-locking mechanism.

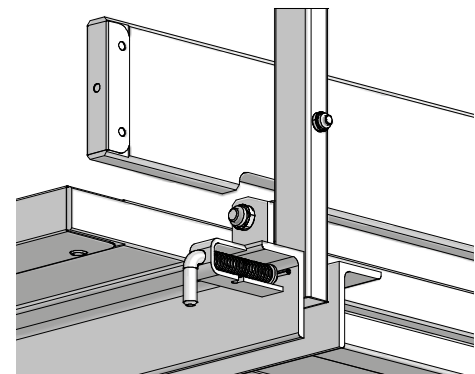


Fig. 35.4

Examples for corner configurations and length compensation

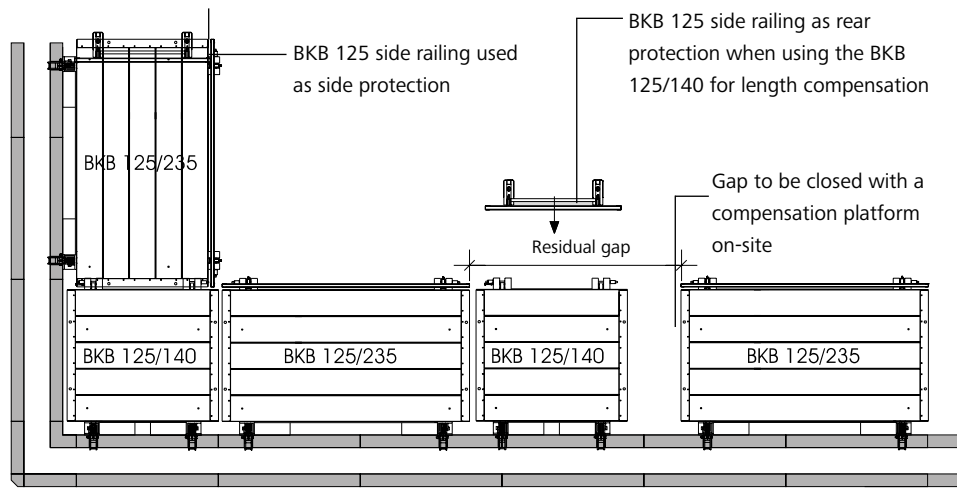


Fig. 35.5

Description	Ref. No.
Folding access platform	
BKB 125/140	29-417-00
BKB 125/235	29-417-10
BKB 125/300	29-417-20
Side railing BKB 125.....	29-417-30

Wall Formwork

Workplaces – Walkway bracket

The pluggable walkway bracket 90 (Fig. 36.1) is mounted to a multi-function profile. To insert the bracket, turn it by 45°, then turn it back to the vertical position and secure it with a flange screw 18 to the multi-function profile below. The planks can then be bolted to the brackets. Maximum bracket spacing for a load of 150 kg/m² (scaffold group 2): 2.50 m according to DIN 12811-1. The minimum thickness of the planks is 4.5 cm and their minimum width is 24 cm.

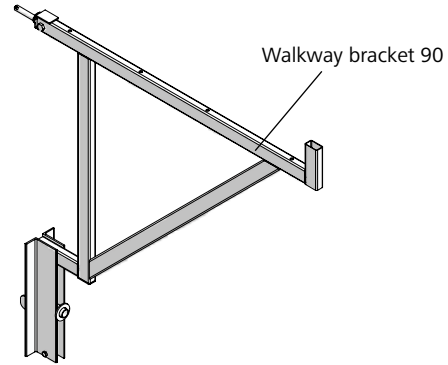


Fig. 36.1

Guardrailing posts and side railing

The guardrailing posts and the side railing (Figures 36.2 to 36.4) are inserted into the walkway brackets. If the fall height exceeds 2.00 m, a side railing (Fig. 36.4) is required.

Note that this regulation is valid for Germany.

Always observe the federal, state and local regulations of the country where the formwork is used. We recommend the use of safety meshes with guardrailing posts 48/120 UK. They are quick and safe method to provide fall protection.

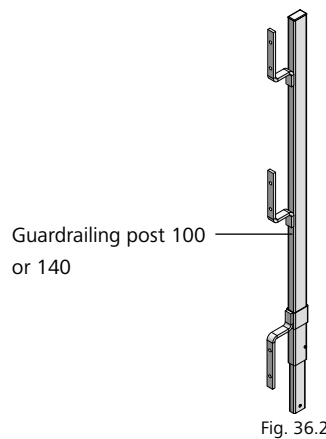


Fig. 36.2

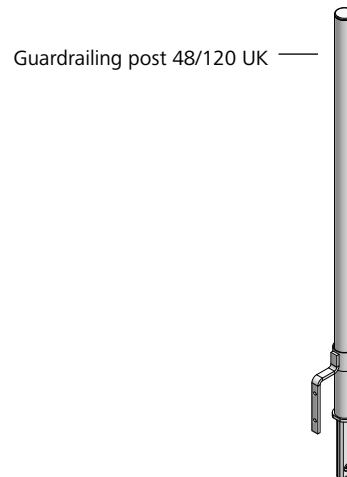


Fig. 36.3

The guardrailing post 48/120 UK can be used to allow scaffold tubes to be installed as a fall protection measure. The guardrailing post is made of a round tube with a diameter of Ø 48 mm to attach swivel-joint couplers for the scaffold tubes and a rectangular adapter so that it can be inserted into the walkway bracket (Fig. 36.3).

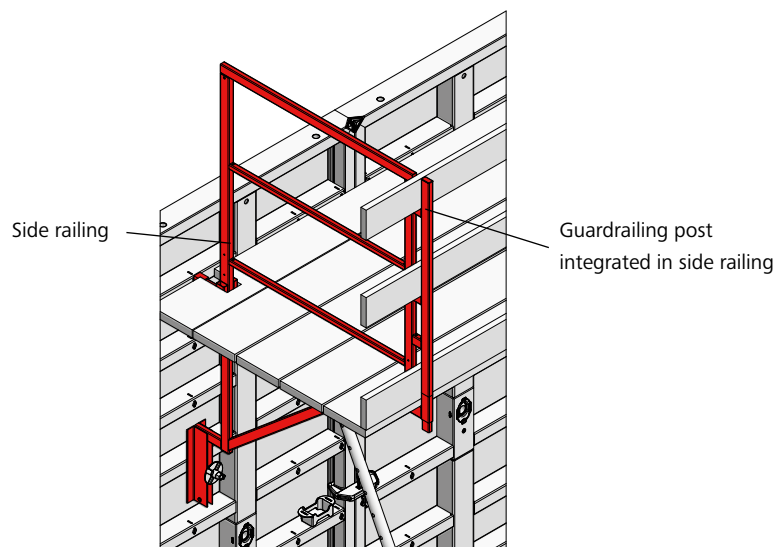


Fig. 36.4

Description	Ref. No.
Walkway bracket 90	29-106-00
Guardrailing post 100	29-106-75
Guardrailing post 140	29-106-85
Guardrailing post 48/120 UK	29-106-80
Side railing 90/100	29-108-20
Swivel-joint coupler	
48/48	29-412-52
Scaffold tube 48/200	29-412-23
Scaffold tube 48/300	29-412-26
Scaffold tube 48/400	29-412-27

Workplaces – Ladder fixture for wall formwork

The ladder fixture for wall formwork enables a ladder or an extension ladder to be firmly attached to the horizontal or vertical wall formwork panel and thus ensures safe access to the working scaffold, e.g. walkway bracket or BKB folding access platform.

The upper ladder fixture for wall formwork is attached to a multi-function nut of the formwork panel with the integrated flange screw. This is used to hook on the ladder. The integrated safety lever prevents the ladder lifting out accidentally.

The lower ladder fixture for wall formwork is attached to the bottom of the wall formwork panel with the integrated flange screw. It is used to secure the ladder.

Both the ladder and the extension ladder can be equipped with a safety cage.

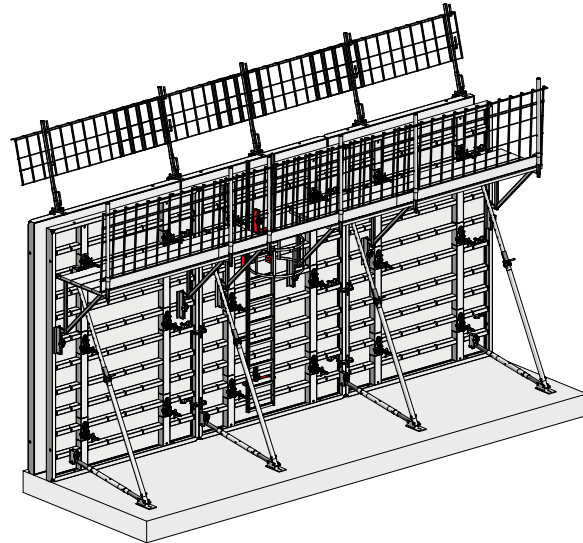


Fig. 37.1

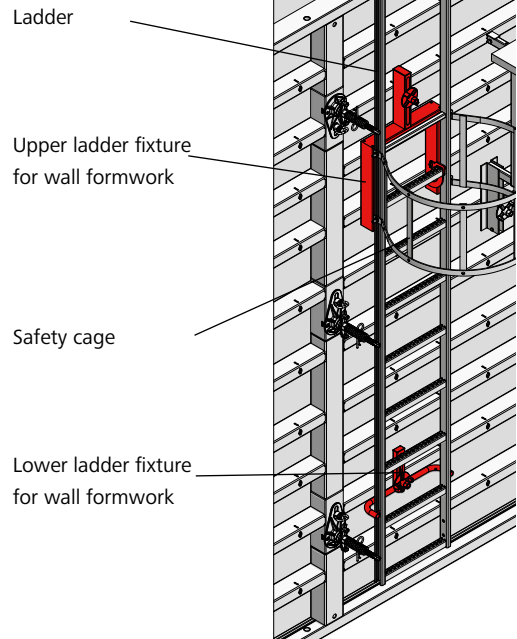


Fig. 37.3

Description	Ref. No.
Ladder fixture for wall formwork	
upper.....	29-416-82
lower.....	29-416-84
Ladder 348.....	29-414-50
Ladder 318.....	29-414-55
Ladder 243.....	29-416-50
Extension ladder 270.....	29-416-52
Extension ladder 210.....	29-414-60
Extension ladder 120.....	29-416-55
Extension ladder 90.....	29-416-60
Extension ladder 60.....	29-416-62
Ladder connector.....	29-414-70
Safety cage 210.....	29-414-85
Safety cage 85.....	29-414-90
Safety cage 40.....	29-416-90

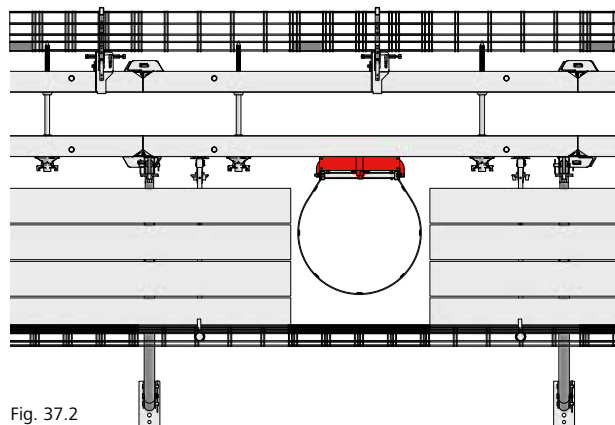


Fig. 37.2

Workplaces – Tilting bracket 40/60

An additional fall protection device on the opposite side of the working scaffolds, i.e. on the other side of the formwork, is required for heights above 2.00 m. Note that this regulation is valid for Germany. Make sure to observe the federal, state and local regulations of the country where the formwork is used.

The tilting bracket 40/60 (Fig. 38.1) is designed for the MEVA wall formwork systems Mammut XT, Mammut 350, Mammut, StarTec XT and StarTec/AluStar and is used to attach MEVA guardrailing posts to create a fall protection system.

It is attached to the panel's frame profile with the integrated wedge (Fig. 38.2).

MEVA guardrailing posts 100, 140 and 48/120 UK can be connected to the bracket.

The tilting bracket can be turned so that it is vertical to facilitate the installation of safety meshes or railing boards. It can also be tilted by 15° to create sufficient room for the concrete bucket (Fig. 38.2).

One guardrailing post per bracket must be ordered separately.

Plug-in support for:
MEVA guardrailing posts 100, 140 and 48/120 UK

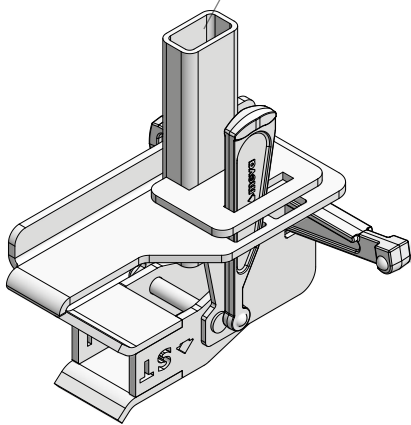


Fig. 38.1

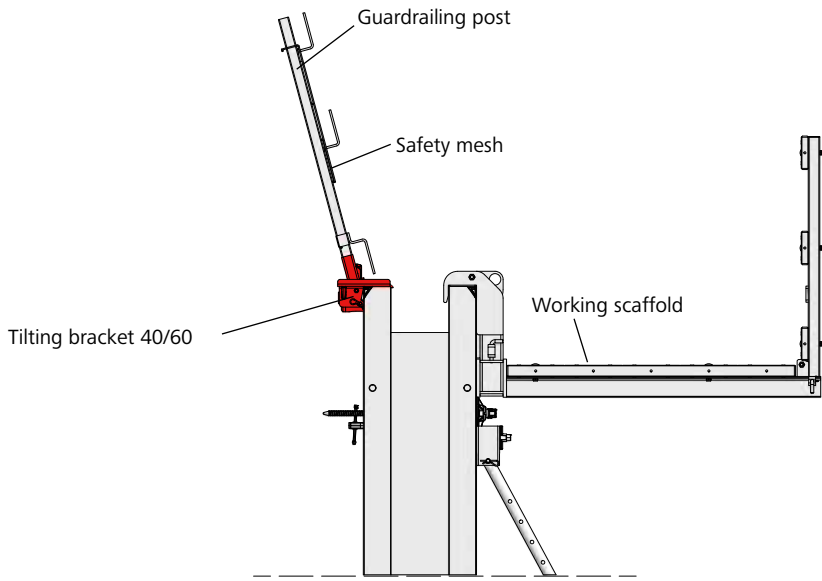


Fig. 38.2

Description	Ref. No.
Tilting bracket 40/60.....	29-920-82
Guardrailing post 100.....	29-106-75
Guardrailing post 140.....	29-106-85
Guardrailing post 48/120 UK ..	29-106-80

Crane Hook

The permissible load of a Mammut crane hook (Fig. 39.1) is 15 kN (1.5 t).

Handling

1. Open the safety lever as far as possible (Fig. 39.3).
2. Push the crane hook over the panel profile until the claw engages completely in the groove.
3. Release the safety lever and press it back to its start position so that the crane hook is locked completely (Fig. 39.4).

Attention

Always use two crane hooks, even when moving single panels. Always attach the crane hooks symmetrically to the centre of gravity.

To ensure that the crane hooks cannot slip, they must be attached as follows:

- across the centre beam for vertical panels, if possible (Fig. 39.5)
- for several panels at the panel joint
- using the cross stiffeners on horizontal panels (Fig. 39.6)

When to replace the crane hook

If the reference dimension exceeds 61 mm, the crane hook must be replaced immediately. This also applies if only one side of the hook exceeds this dimension (Fig. 39.2).

Safety check

Always check the crane hook before use. Do not overload the crane hook. Exceeding the permissible loading can result in excessive elongation and thus permanent deformation. A damaged crane hook is not capable of supporting the full load and its safe use can no longer be guaranteed.

Safety regulations

When using our products, the federal, state and local codes and regulations must be observed.

Also observe the operating instructions delivered with the crane hook.

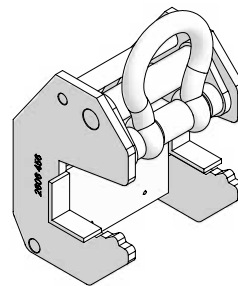


Fig. 39.1

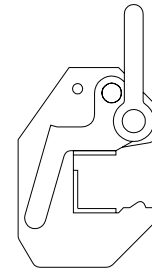


Fig. 39.2

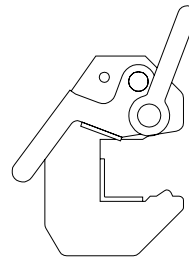


Fig. 39.3

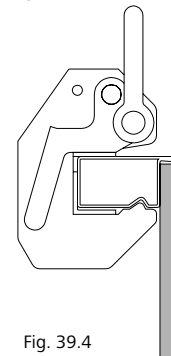


Fig. 39.4

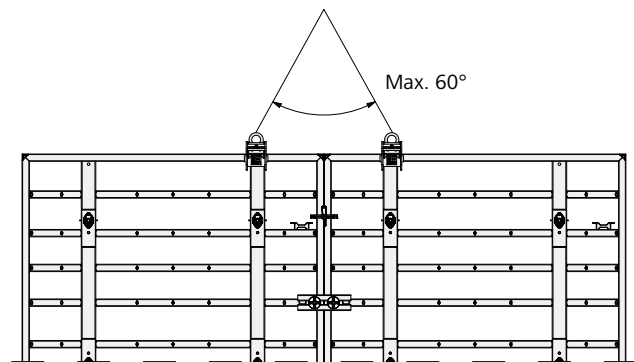


Fig. 39.5

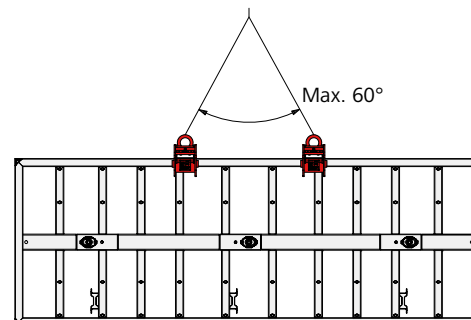


Fig. 39.6

Description	Ref. No.
M crane hook	29-401-21

Wall Formwork

90° corner

With Mammut XT, a 90° corner can be produced for all wall thickness (WT) in 5 cm increments without filler areas. To do this, three outer-corner sizes (Figures 40.1 and 40.2) and two inner-corner sizes (Figures 40.3 and 40.4) are available for use in conjunction with standard Mammut XT panels.

The longitudinal struts on XT outside and XT inside corners enable them to be transported by crane. If the lifting gear is attached to the longitudinal struts, only a single corner may be lifted at any one time.

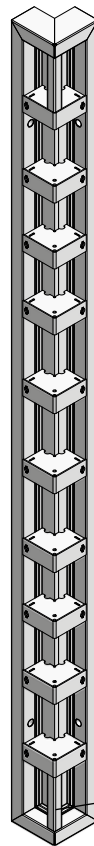


Fig. 40.1

Mammut XT 90° outside corners

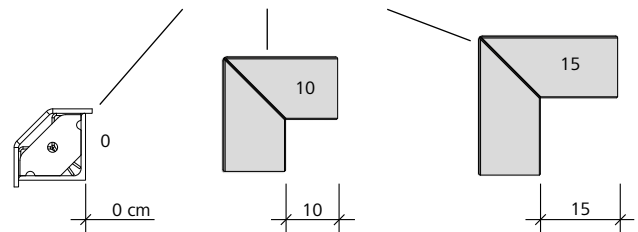


Fig. 40.2

Longitudinal strut

Longitudinal strut

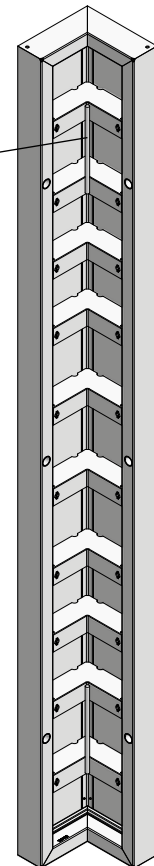


Fig. 40.4

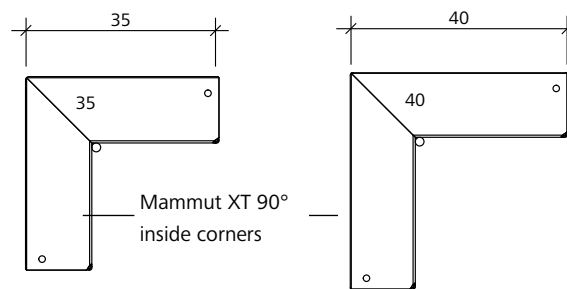


Fig. 40.3

 Mammut XT 90°
inside corners

Description	Ref. No.
Mammut XT outside corner	
Mammut XT OC 350/10	23-152-50
Mammut XT OC 350/15	23-152-70
Mammut XT OC 300/10	23-152-55
Mammut XT OC 300/15	23-152-75
Mammut XT OC 250/10	23-152-60
Mammut XT OC 250/15	23-152-80
Mammut XT OC 125/10	23-152-65
Mammut XT OC 125/15	23-152-85
Mammut 350 OC 350.....	23-140-30
M outside corner	
Mammut OC 300.....	23-140-00
Mammut OC 250.....	23-140-10
Mammut OC 125.....	23-140-20
Mammut XT inside corner	
Mammut XT IC 350/35	23-152-00
Mammut XT IC 350/40	23-152-20
Mammut XT IC 300/35	23-152-05
Mammut XT IC 300/40	23-152-25
Mammut XT IC 250/35	23-152-10
Mammut XT IC 250/40	23-152-30
Mammut XT IC 125/35	23-152-15
Mammut XT IC 125/40	23-152-35

Wall Formwork

90° corner

To create 90° corners, standard Mammut XT panels with widths 50 and 75 cm are used in conjunction with Mammut XT inner and outside corners (Figures 41.1 to 41.6).

The system parts required for the most common wall thickness are listed in Table 41.7.

If different wall thicknesses meet, the aluminium filler can be used to close the residual gap (Figures 41.8 and 41.9). The filler has tie holes. DW tie rods are used on both sides when using the tie holes in the filler. For stabilisation, a cross stiffener 44 must be attached with two flange screws 18 at each tie hole level (Fig. 41.9).

Different wall thickness outside of the 5 cm increments are compensated for using job-built wood fillers (see page XT-44).

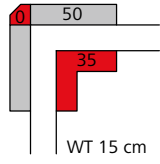


Fig. 41.1

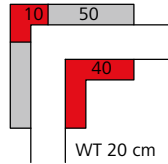


Fig. 41.2

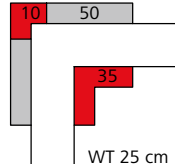


Fig. 41.3

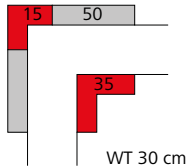


Fig. 41.4

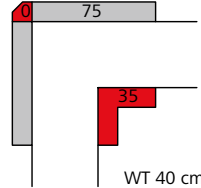


Fig. 41.5

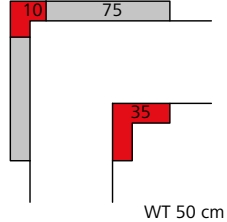


Fig. 41.6

Corner combinations

WT (in cm)	Mammut XT 90° outside corners			Mammut XT 90° inside corners		Mammut XT panels	
	OC 0	OC 10	OC 15	IC 35	IC 40	50	75
15	1			1		2	
20		1			1	2	
25		1		1		2	
30			1	1		2	
35	1				1		2
40	1			1			2
45		1			1		2
50		1		1			2

Table 41.7

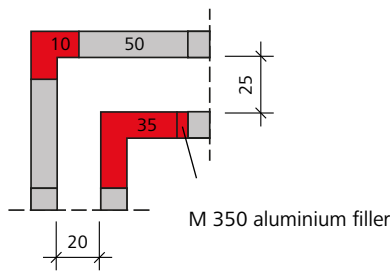


Fig. 41.8

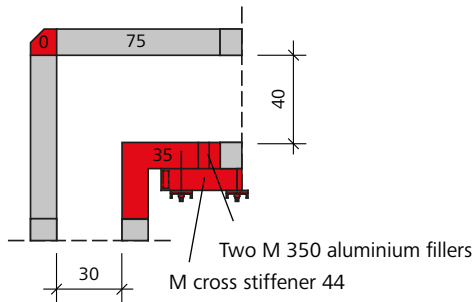


Fig. 41.9

Description	Ref. No.
M 350 aluminium filler 350/8.	29-300-27
M 350 aluminium filler 350/6.	29-300-28
M 350 aluminium filler 350/5.	29-300-30
M 350 aluminium filler 350/4.	29-300-31
M XT aluminium filler 300/8...	29-300-43
M XT aluminium filler 300/6...	29-300-44
M XT aluminium filler 300/5...	29-300-45
M XT aluminium filler 300/4...	29-300-46
M 350 aluminium filler 250/8.	29-300-33
M 350 aluminium filler 250/6.	29-300-34
M 350 aluminium filler 250/5.	29-300-35
M 350 aluminium filler 250/4.	29-300-36
M 350 aluminium filler 125/8.	29-300-38
M 350 aluminium filler 125/6.	29-300-39
M 350 aluminium filler 125/5.	29-300-40
M 350 aluminium filler 125/4.	29-300-41
M cross stiffener 44	29-401-02
Flange screw 18	29-401-10

90° corner – Single-sided tying

For single-sided tying at the corner a 25 cm wide XT panel is installed next to the XT inside corner and next to the XT panel opposite (50 or 75 cm wide) (Figures 42.1 to 42.4).

For any desired pouring height and wall thickness, an M alignment rail 75 is fitted to the multi-function profile of the panel across the 25 cm wide panel for stabilisation purposes (Figures 42.1 and 42.2).

The number of alignment rails depends on the number of tie holes in the panel.

For pouring heights up to 350 cm and wall thicknesses up to 30 cm the M alignment rail is not required (Figures 42.3 and 42.4 and Table 4646.6).

Attention

Unused tie holes must always be closed with plug D35/38 or alternatively with XT sealing cone with a pressed-on plug D20 (see page XT-18).

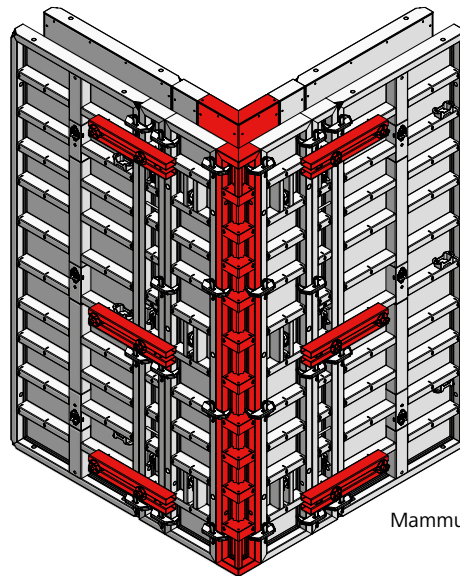


Fig. 42.1

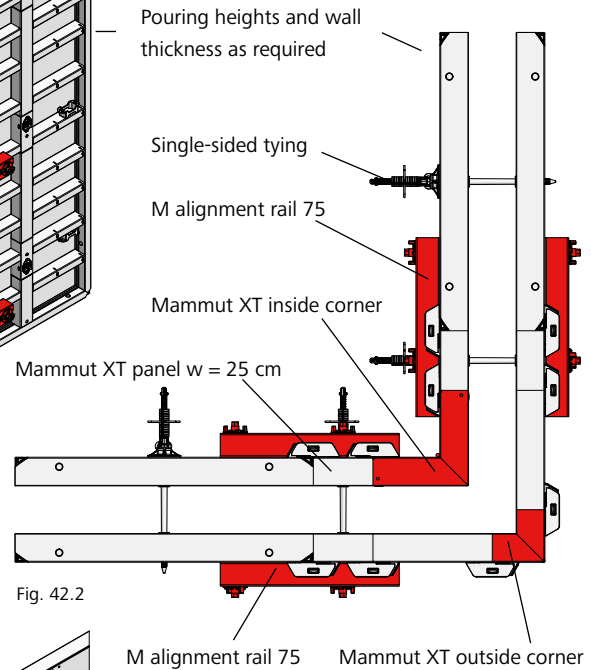


Fig. 42.2

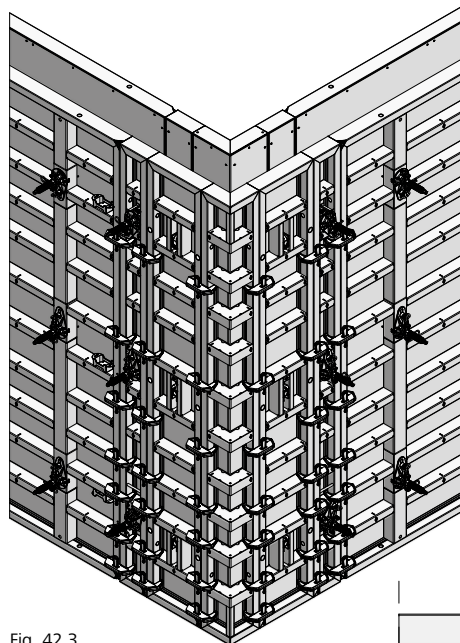


Fig. 42.3

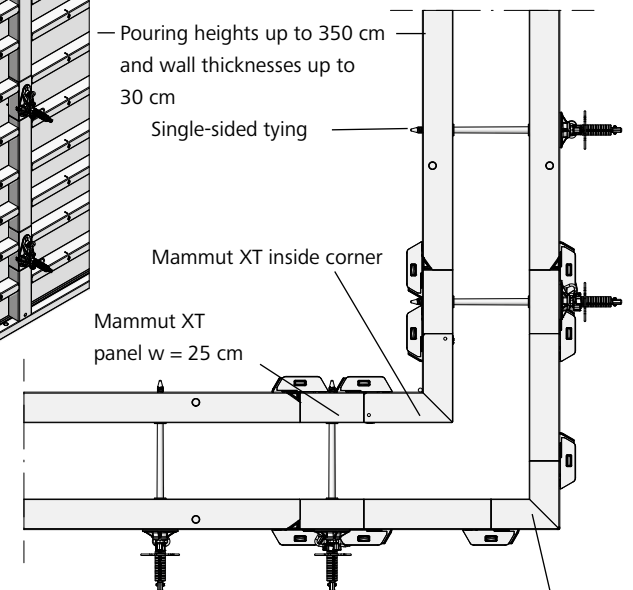


Fig. 42.4

Description	Ref. No.
M alignment rail 75	29-400-95
Flange screw 18.....	29-401-10
XT sealing cone 5 AL20	29-902-34
XT sealing cone 10 AL20	29-902-35
Plug D35/38	29-902-71
Plug D20, red.....	29-902-63

90° corner – Two-sided tying

Besides central tie holes, the 50 and 75 cm Mammut XT panels (Fig. 43.1) also have conical anchor sleeves in the frame. These allow two-sided tying at the corners (Figures 43.2 and 43.3).

Attention

Unused tie holes must always be closed with plug D35/38 or alternatively with XT sealing cone with a pressed-on plug D20 (see page XT-18).

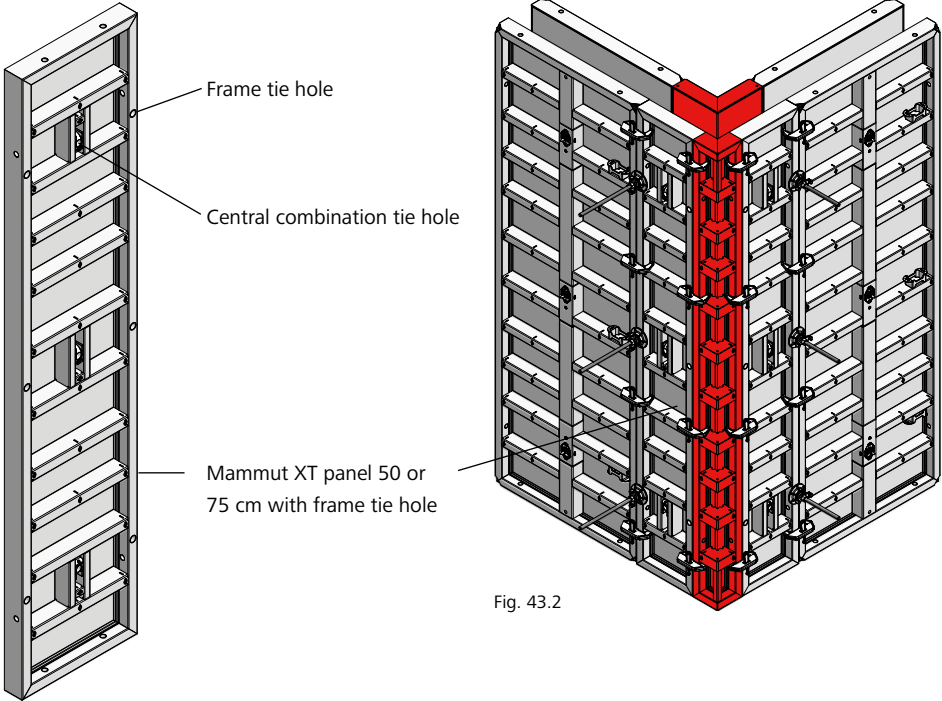


Fig. 43.1

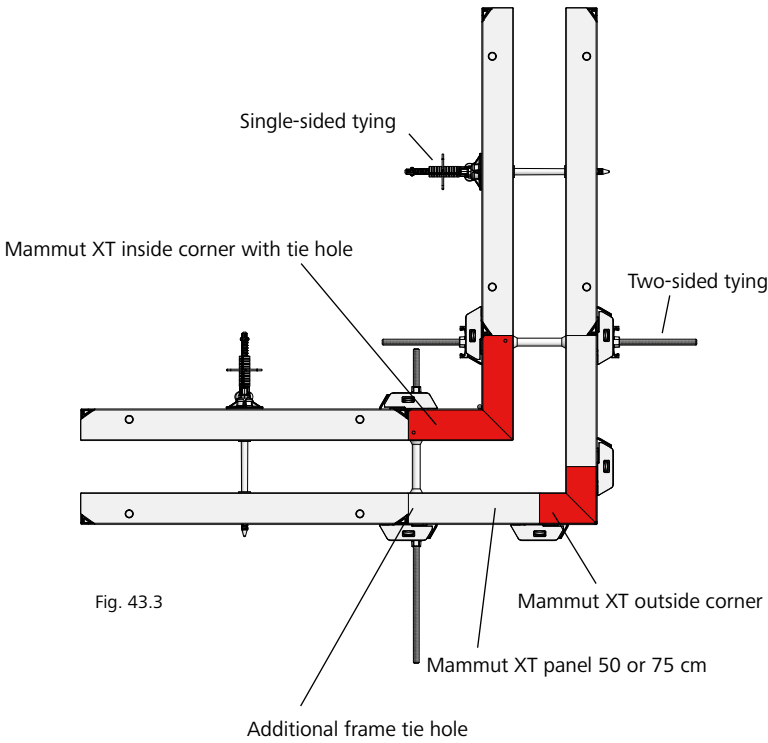


Fig. 43.3

Description	Ref. No.
XT sealing cone 5 AL20	29-902-34
XT sealing cone 10 AL20	29-902-35
Plug D35/38	29-902-71
Plug D20, red.....	29-902-63

Wall Formwork

90° corner – Inside corner

The Mammut XT inside corner is galvanised and has an alkus all-plastic facing.

The inside corner (Fig. 44.1) has tie holes. Only three assembly locks per joint are required for height 350 cm, all other heights require two assembly locks per side. The side length is 35 cm (Fig. 44.2) or 40 cm (Fig. 44.3), see page XT-40.

Inside corner with wood filler

The connection is achieved with three Uni- or RS assembly locks for height 350 cm and with two assembly locks for all other heights. For stabilisation, a cross stiffener 44 must be attached with a flange screw 18 to the multifunction profiles at each tie hole level (Fig. 44.4).

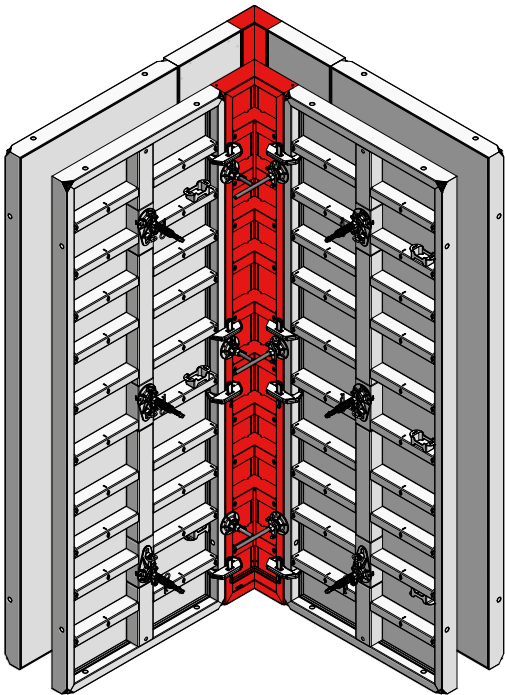


Fig. 44.1

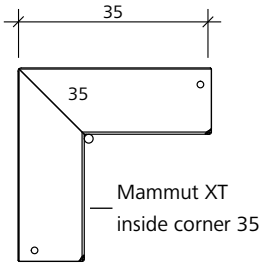


Fig. 44.2

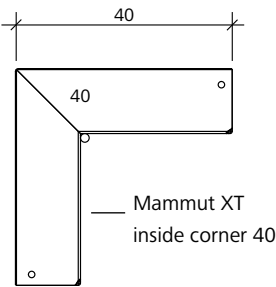


Fig. 44.3

Wide wood filler:

- RS assembly lock from 0 to 8.5 cm
- Uni-assembly lock 22 from 0 to 10 cm
- Uni-assembly lock 28 from 0 to 16 cm

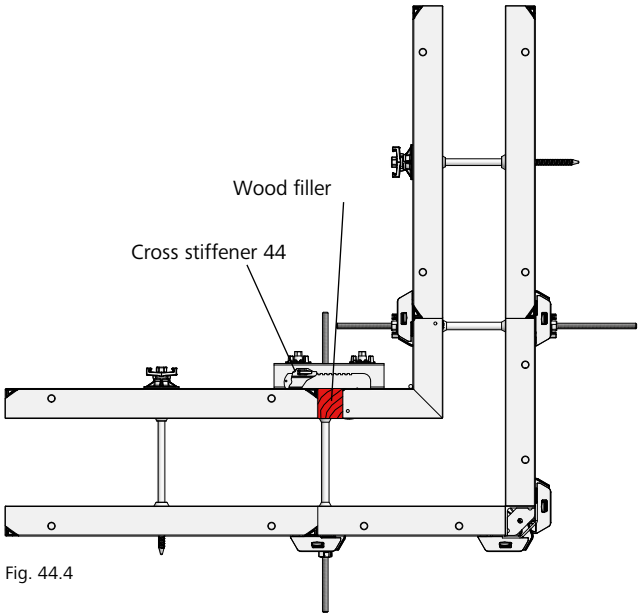


Fig. 44.4

Description	Ref. No.
M cross stiffener 44	29-401-02
M assembly lock	29-400-71
Uni-assembly lock 22	29-400-85
Uni-assembly lock 28	29-400-90
RS assembly lock	23-807-70
Flange screw 18	29-401-10

90° corner – Outside corner

The Mammut XT outside corners 0, 10 and 15 (Fig. 45.3) together with the Mammut XT panels and the M assembly lock result in a solid 90° outside corner solution (Figures 45.1 and 45.2 and page XT-40).

For the number of M assembly locks required for a Mammut XT outside corner (a), for the next panel joint (b) as well as for the standard panel joint (c) refer to Table 45.6. This applies to both single-sided (Fig. 45.1) and two-sided tying (Fig. 45.2) in the corner area. For the assembly locks and alignment rails required for height-extended outside corners refer to page XT-47.

Instead of using the Mammut XT outside corner, two Mammut XT panels can be butt jointed. In this case, the panels are then bolted together using M outside corner brackets and flange screws 18 (Fig. 45.5). Refer to Table 45.7 for the number of M outside corner brackets required.

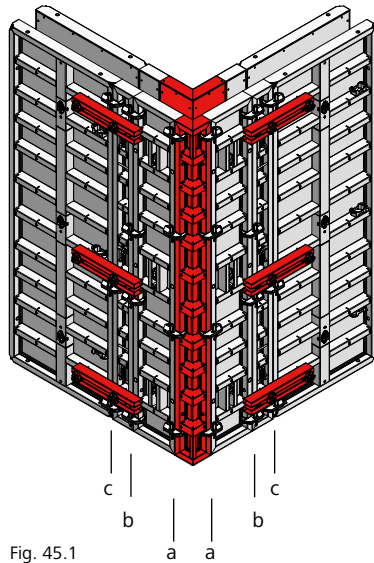


Fig. 45.1

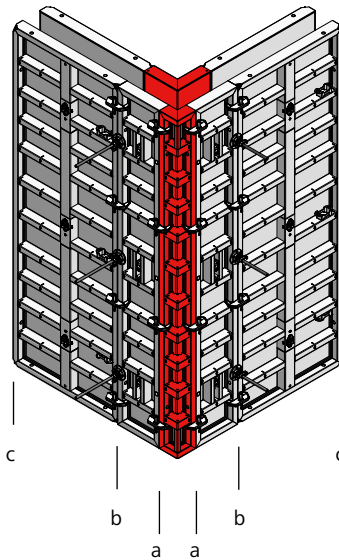


Fig. 45.2

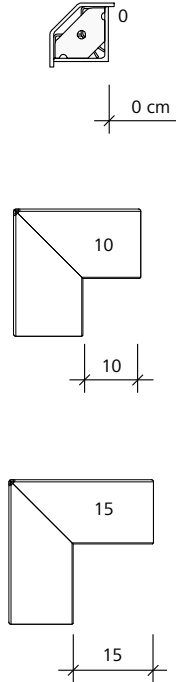


Fig. 45.3

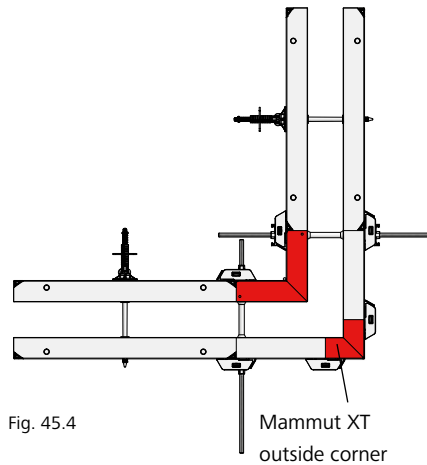


Fig. 45.4

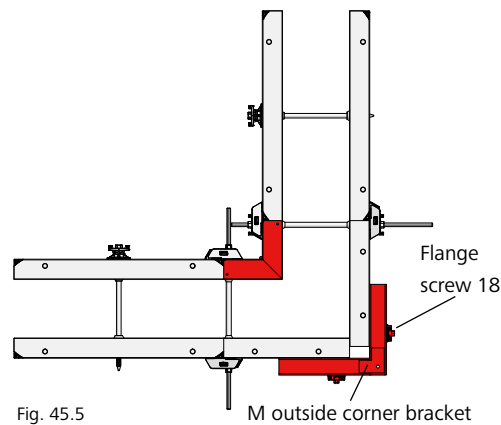


Fig. 45.5

Panel height (in cm)	Number of M assembly locks (single-sided and two-sided tying)		
	(a)	(b)	(c)
350	4	4	3
300	3	3	2
250	3	2	2
125	2	2	2

Table 45.6

Panel height (in cm)	Number of M outside corner brackets	Number of M assembly locks (b)
350	4	4
300	3	3
250	2	2
125	2	2

Table 45.7

Description	Ref. No.
M cross stiffener 44.....	29-401-02
M assembly lock.....	29-400-71
Uni-assembly lock 22.....	29-400-85
Uni-assembly lock 28.....	29-400-90
M outside corner bracket.....	23-137-63
Flange screw 18.....	29-401-10

Wall Formwork

90° corner – Outside corner

When forming corners by means of single-sided tying (see page XT-42), the M alignment rail is not required for pouring heights up to 350 cm and wall thicknesses up to 30 cm (Figures 46.1 to 46.5).

Attention must be paid to the number of M assembly locks required and their exact position at the outside corner (a) and at the panel joints (b) and (c) in accordance with the pouring height (Figures 46.2 to 46.5 and Table 46.6).

For the position of the M assembly locks refer to Figures 46.2 to 46.5.

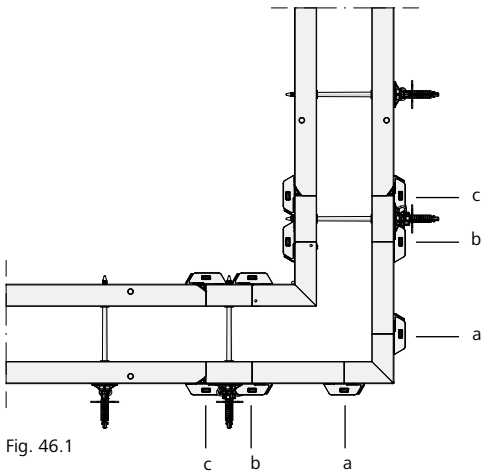


Fig. 46.1

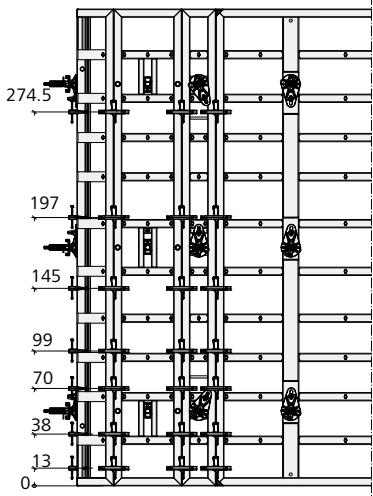


Fig. 46.2 Up to a pouring height of 350 cm

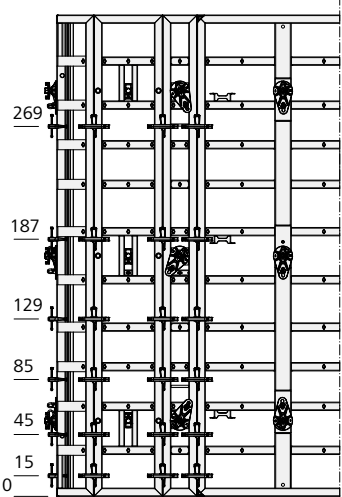


Fig. 46.3 Up to a pouring height of 330 cm

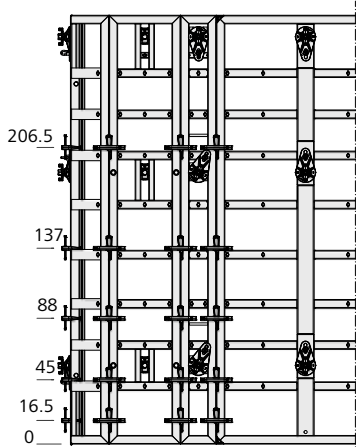


Fig. 46.4 Up to a pouring height of 290 cm

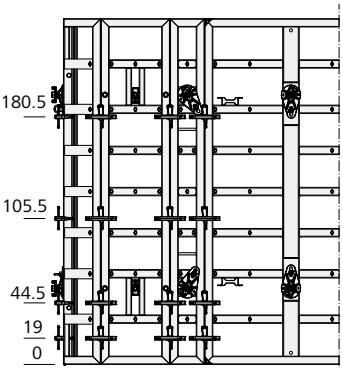


Fig. 46.5 Up to a pouring height of 250 cm

Pouring height (in cm)	Number of M assembly locks (single-sided tying up to h = 350 cm and WT = 30 cm)		
	(a)	(b)	(c)
350	7	7	7
330	6	6	6
310	6	6	6
290	5	5	5
270	5	5	5
250	4	4	4

Table 46.6

90° corner – Height-extended outside corner

Pouring heights of 4.25 m or higher require the number of assembly locks and alignment rails shown in Table 47.3.

The alignment rails must be attached to the panels with two flange screws 18. Always start attaching the alignment rails at the bottom multi-function profile, i.e. the first alignment rail must be attached to the bottom multifunction profile of the bottom outside corner. Note that the alignment rails must cover the next panel joint and be bolted at the corners (Figures 47.1 and 47.2).

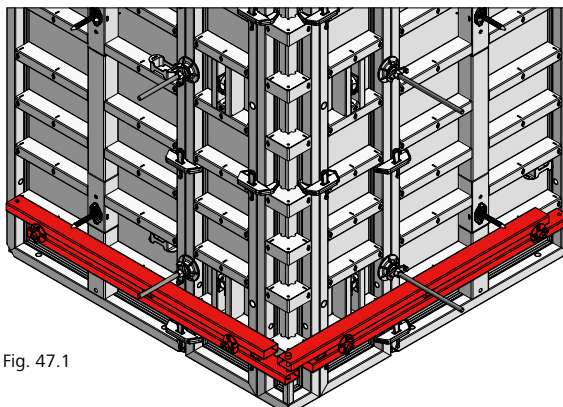


Fig. 47.1

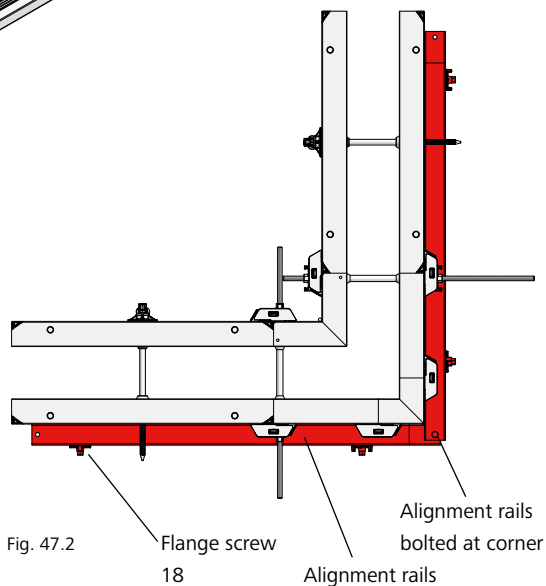


Fig. 47.2

Height-extended outside corner						
Pouring height (cm)	Number of alignment rails (from bottom to top) at wall thickness (cm)					Number of M assembly locks
	0-25	26-50	51-75	76-100	101-125	
425	—	—	—	1	1	10
475	—	—	—	1	1	10
500	—	—	—	1	1	11
550	—	—	—	2	2	12
600	—	—	1	2	2	13
650	1	1	1	2	2	14
700	1	1	1	2	2	15
750	1	1	1	2	2	16
800	2	2	2	3	3	17
850	2	2	2	3	3	18
900	2	2	2	3	3	19
950	3	3	3	4	4	20

Table 47.3

Description	Ref. No.
M alignment rail 180	29-400-92
M alignment rail 250	29-402-50
Flange screw 18.....	29-401-10

Wall Formwork

Hinged corner

Acute and obtuse angled corners are formed using hinged inside and outside corners (Fig. 48.1).

Side length

- Outside corner 12.5 cm
- Inside corner 40 cm

Adjustment range:

60° to 180°

At the outside corner, alignment rails must be attached to the multi-function profiles with flange screws.

If the inside angle α is greater than 100°, alignment rails and a wooden blocking are also required on the inside (Fig. 48.2).

Timber fillers and Uni-assembly locks are used for length compensation (Figures 48.1 and 48.2).

The hinged outside and inside corners can be set to an angle of 70°, 90°, 120°, 135° or 180° with a locking device (Fig. 48.3).

Height 300

If 300 cm high M hinged corners are used, Mammut 350/Mammut panels are to be used next to the hinged outside corner.

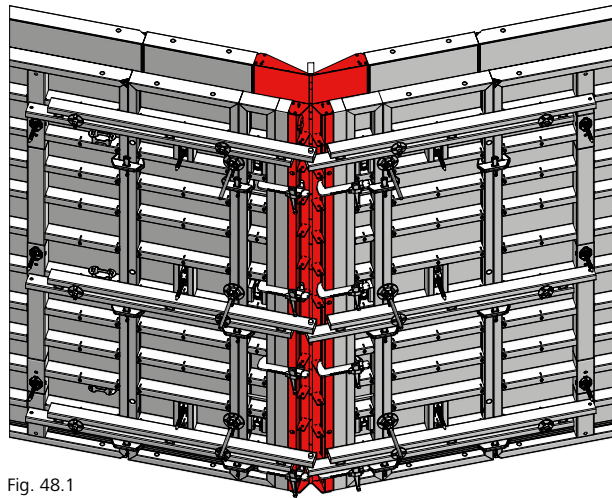


Fig. 48.1

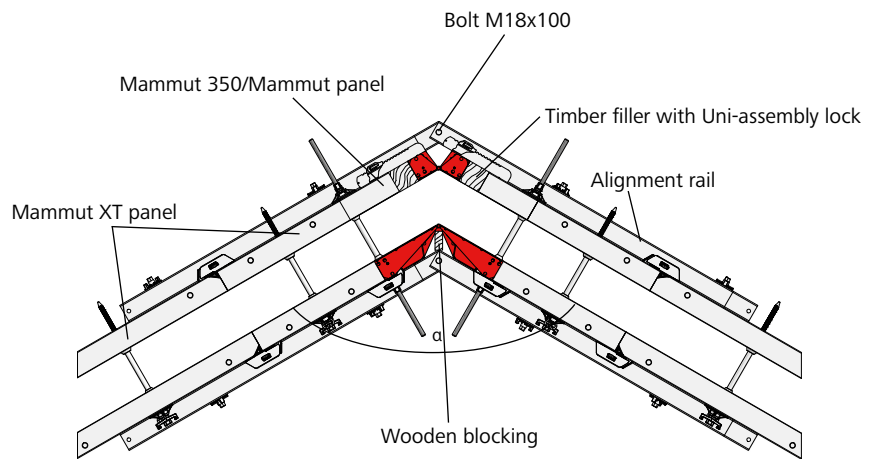


Fig. 48.2

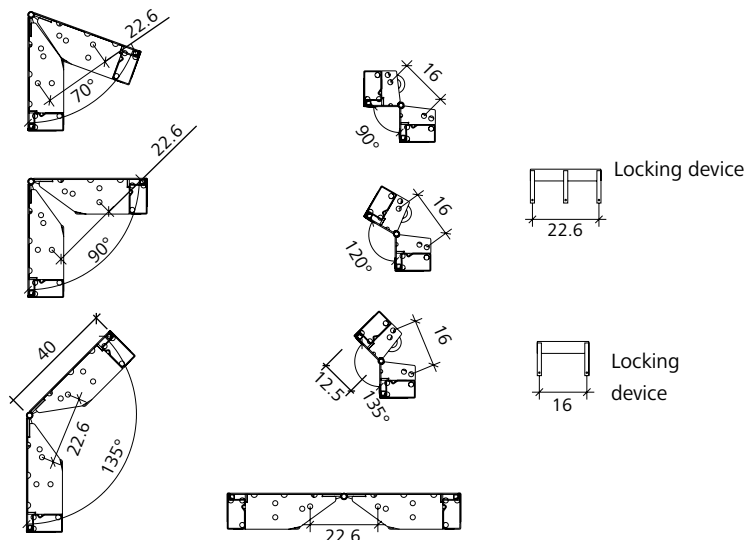


Fig. 48.3

Description	Ref. No.
M hinged corners	
Mammut 350 HOC 350/12,5	23-137-70
Mammut 350 HIC 350/40	23-137-30
Mammut XT hinged corner	
Mammut XT HOC 300	23-137-93
Mammut XT HIC 300	23-137-53
M hinged corner	
Mammut HOC 300/12.5	23-137-71
Mammut HIC 300/40	23-137-31
Mammut HOC 250/12.5	23-137-81
Mammut HIC 250/40	23-137-41
Mammut HOC 125/12.5	23-137-91
Mammut HIC 125/40	23-137-51

Hinged corner

The dimension y (Fig. 49.1), which represents the gap between the hinged outside corner and the first double-sided standard Mammut XT panel, can either be calculated using the adjacent formula or can be determined using Table 49.2, depending on the inside angle and the wall thickness.

Height 300

If 300 cm high M hinged corners are used, Mammut 350/Mammut panels are to be used next to the hinged outside corner.

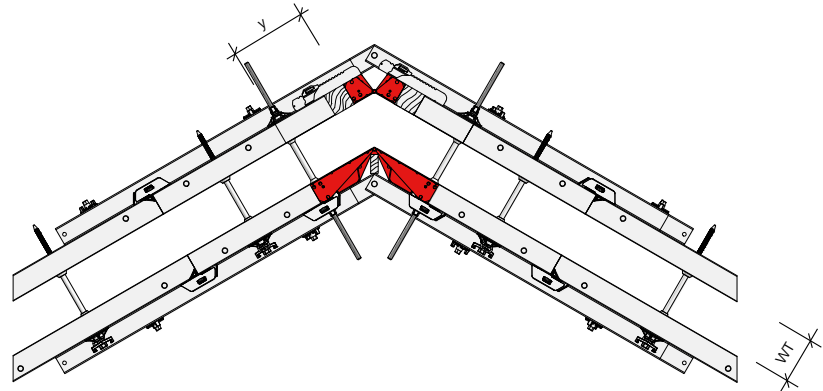


Fig. 49.1

WT = wall thickness

$$\text{Equation to calculate the width } y \text{ (in cm)} = \frac{WT}{\tan \frac{\alpha}{2}} + 27.5$$

Inside angle (α)	Wall thickness (WT)						
	24 cm	25 cm	30 cm	35 cm	40 cm	45 cm	50 cm
60°	Y = 69.1	Y = 70.8	Y = 79.5	Y = 88.1	Y = 96.8	Y = 105.4	Y = 114.1
65°	Y = 65.2	Y = 66.7	Y = 74.6	Y = 82.4	Y = 90.3	Y = 98.1	Y = 106.0
70°	Y = 61.8	Y = 63.2	Y = 70.3	Y = 77.5	Y = 84.6	Y = 91.8	Y = 98.9
75°	Y = 58.8	Y = 60.1	Y = 66.6	Y = 73.1	Y = 79.6	Y = 86.1	Y = 92.7
80°	Y = 56.1	Y = 57.3	Y = 63.3	Y = 69.2	Y = 75.2	Y = 81.1	Y = 87.1
85°	Y = 53.7	Y = 54.8	Y = 60.2	Y = 65.7	Y = 71.2	Y = 76.6	Y = 82.1
90°	Y = 51.5	Y = 52.5	Y = 57.5	Y = 62.5	Y = 67.5	Y = 72.5	Y = 77.5
95°	Y = 49.5	Y = 50.4	Y = 55.0	Y = 59.6	Y = 64.2	Y = 68.7	Y = 73.3
100°	Y = 47.6	Y = 48.5	Y = 52.7	Y = 56.9	Y = 61.1	Y = 65.3	Y = 69.5
105°	Y = 45.9	Y = 46.7	Y = 50.5	Y = 54.4	Y = 58.2	Y = 62.0	Y = 65.9
110°	Y = 44.3	Y = 45.0	Y = 48.5	Y = 52.0	Y = 55.5	Y = 59.0	Y = 62.5
115°	Y = 42.8	Y = 43.4	Y = 46.6	Y = 49.8	Y = 53.0	Y = 56.2	Y = 59.4
120°	Y = 41.4	Y = 41.9	Y = 44.8	Y = 47.7	Y = 50.6	Y = 53.5	Y = 56.4
125°	Y = 40.0	Y = 40.5	Y = 43.1	Y = 45.7	Y = 48.3	Y = 50.9	Y = 53.5
130°	Y = 38.7	Y = 39.2	Y = 41.5	Y = 43.8	Y = 46.2	Y = 48.5	Y = 50.8
135°	Y = 37.4	Y = 37.9	Y = 39.9	Y = 42.0	Y = 44.1	Y = 46.1	Y = 48.2
140°	Y = 36.2	Y = 36.6	Y = 38.4	Y = 40.2	Y = 42.1	Y = 43.9	Y = 45.7
145°	Y = 35.1	Y = 35.4	Y = 37.0	Y = 38.5	Y = 40.1	Y = 41.7	Y = 43.3
150°	Y = 33.9	Y = 34.2	Y = 35.5	Y = 36.9	Y = 38.2	Y = 39.6	Y = 40.9
155°	Y = 32.8	Y = 33.0	Y = 34.2	Y = 35.3	Y = 36.4	Y = 37.5	Y = 38.6
160°	Y = 31.7	Y = 31.9	Y = 32.8	Y = 33.7	Y = 34.6	Y = 35.4	Y = 36.3
165°	Y = 30.7	Y = 30.8	Y = 31.4	Y = 32.1	Y = 32.8	Y = 33.4	Y = 34.1
170°	Y = 29.6	Y = 29.7	Y = 30.1	Y = 30.6	Y = 31.0	Y = 31.4	Y = 31.9
175°	Y = 28.5	Y = 28.6	Y = 28.8	Y = 29.0	Y = 29.2	Y = 29.5	Y = 29.7
180°	Y = 27.5	Y = 27.5	Y = 27.5	Y = 27.5	Y = 27.5	Y = 27.5	Y = 27.5

Table 49.2

Description	Ref. No.
M alignment rail 180	29-400-92
M alignment rail 250	29-402-50
Flange screw 18	29-401-10
Uni-assembly lock 22	29-400-85
Uni-assembly lock 28	29-400-90

Stripping corner

The M stripping corners 350 (Fig. 50.1), 300, 250 and 125 allow the formwork to be removed safely and quickly from poured shaft walls, for example, without damaging the walls or formwork. They function according to the "jumping jack" principle.

The stripping corner is a three-piece design to permit inward movement of the lateral parts.

The side length is 25 cm.

The height of the stripping corner can be increased easily (Fig. 50.1).

After pouring and when the concrete has set sufficiently, all stripping corners are activated (Fig. 50.2 and pages XT-54 to -56) and the entire formwork can be lifted out of the shaft as one single unit with a 4-rope crane sling (Fig. 50.3). There is no need to disassemble the formwork. For details see Figures 50.4 A and 50.5 B.

Note

- Before pouring, cover the joints on the sides of the stripping corner with adhesive tape to make it easier to clean.
- Make sure the entire formwork is completely removed from the poured walls before lifting it by crane.

Height 300

If 300 cm high outside corners are used, Mammut 350/Mammut panels are to be used next to the XT outside corner.

Attention

When slinging with several strands, only two strands may be considered to be load-bearing according to the Berufsgenossenschaft (the German employers' liability insurance association). This does not apply if it has been ensured that the load is distributed evenly over further strands or if the permissible loading of the individual strands is not exceeded in the event of an unequal load distribution.

The maximum permissible loading of the crane eye per stripping corner is 10 kN (1 ton). This results in a permissible total weight of the complete shaft formwork of 40 kN (4 tons) if it has been ensured that the load is evenly distributed (the contractor is responsible for this). Otherwise, the permissible total weight is 20 kN (2 tons).
 The permissible loading of the M crane hook is 15 kN (1.5 tons). This results in a permissible total weight of the complete shaft formwork of 60 kN (6 tons) if it has been ensured that the load is evenly distributed (the contractor is responsible for this). Otherwise, the permissible total weight is 30 kN (3 tons).
 For higher loads, a spreader beam must be used.

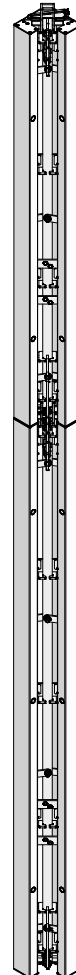


Fig. 50.1

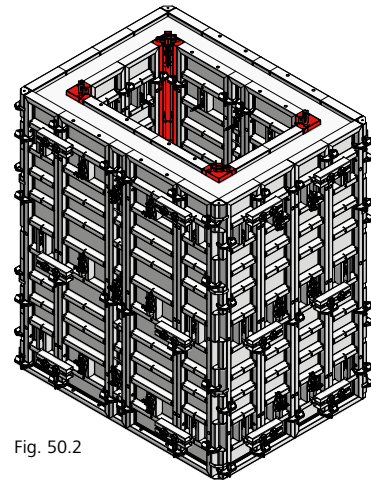


Fig. 50.2

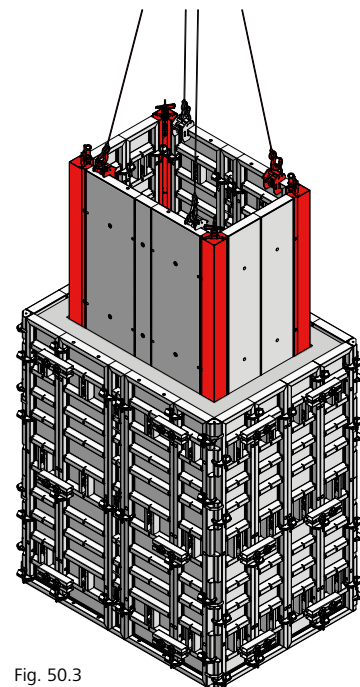


Fig. 50.3

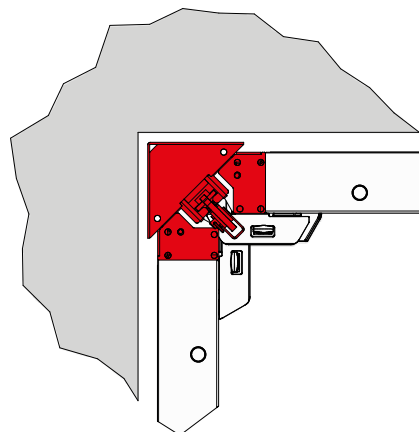


Fig. 50.4 A

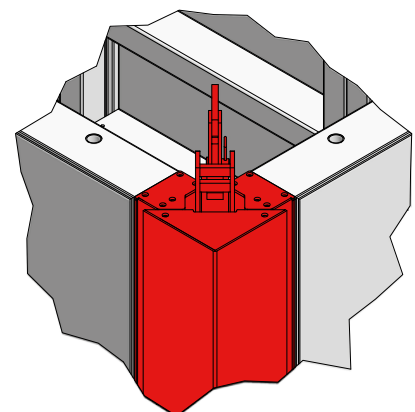


Fig. 50.5 B

Description	Ref. No.
M 350 stripping corner	
Mammut 350 SC 350/25	23-151-00
Mammut 350 SC 300/25	23-151-10
Mammut 350 SC 250/25	23-151-20
Mammut 350 SC 125/25	23-151-30
Adhesive tape	41-912-10

Stripping corner

Attachment and position of assembly locks

The function of the stripping corner can only be guaranteed if the assembly locks connecting the stripping corner to the panels are positioned in certain areas of the stripping corner.

No assembly locks can be attached and positioned in the grey shaded areas.

Height 350 cm requires three assembly locks (Fig. 51.1).

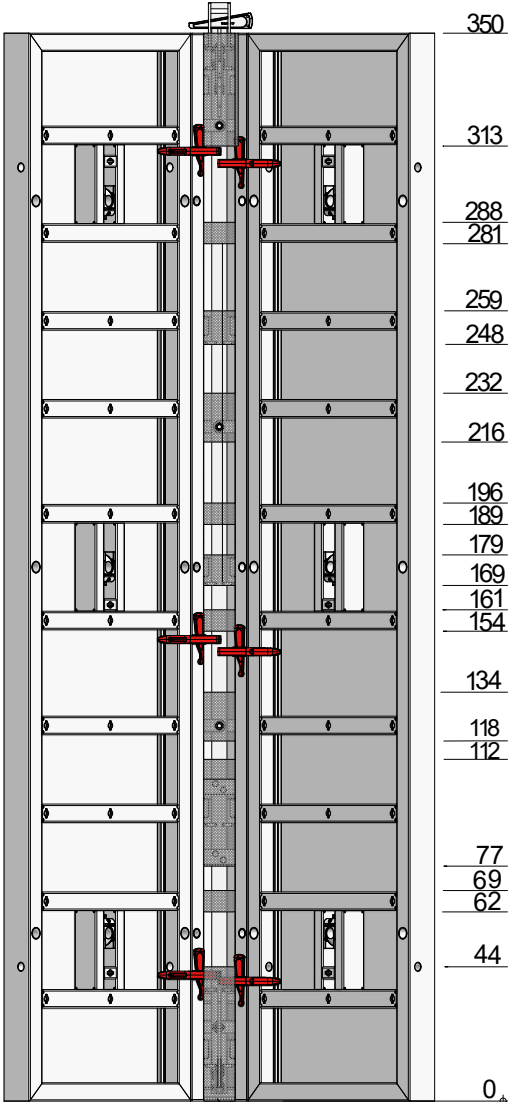
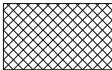


Fig. 51.1

M stripping corner 350/25



No assembly locks possible in grey shaded areas!

Description	Ref. No.
Mammut 350 SC 350/25	23-151-00

Stripping corner

Attachment and position of assembly locks

The function of the stripping corner can only be guaranteed if the assembly locks connecting the stripping corner to the panels are positioned in certain areas of the stripping corner.

No assembly locks can be attached and positioned in the grey shaded areas.

Height 300 cm requires two assembly locks (Fig. 52.1).

Note

If 300 cm high outside corners are used, Mammut 350/Mammut panels are to be used next to the XT outside corner.

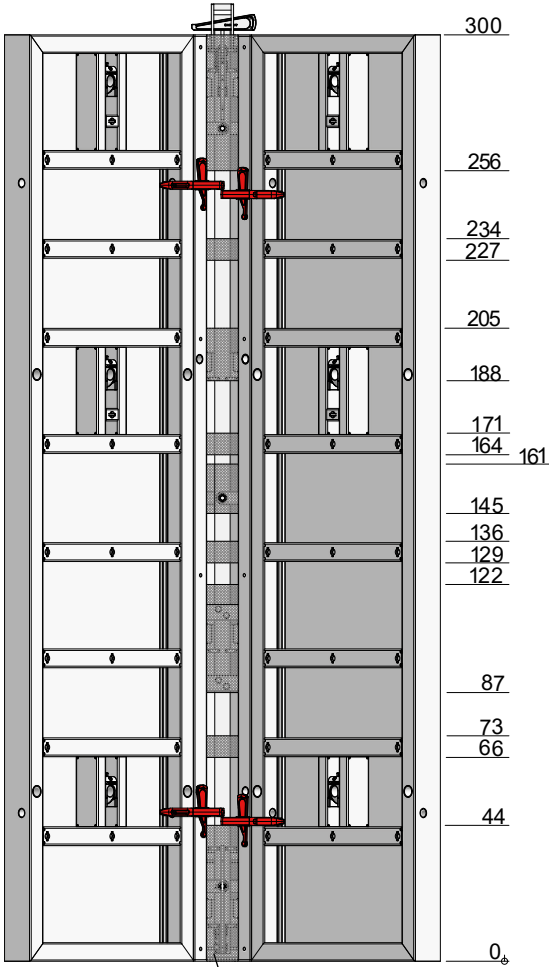
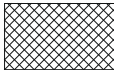


Fig. 52.1

M stripping corner 300/25



No assembly locks possible in grey shaded areas!

Description	Ref. No.
Mammut 350 SC 300/25	23-151-10

Stripping corner

Attachment and position of assembly locks

The function of the stripping corner can only be guaranteed if the assembly locks connecting the stripping corner to the panels are positioned in certain areas of the stripping corner.

No assembly locks can be attached and positioned in the grey shaded areas.

Up to a height of 250 cm two assembly locks are required (Figures 53.1 and 53.2).

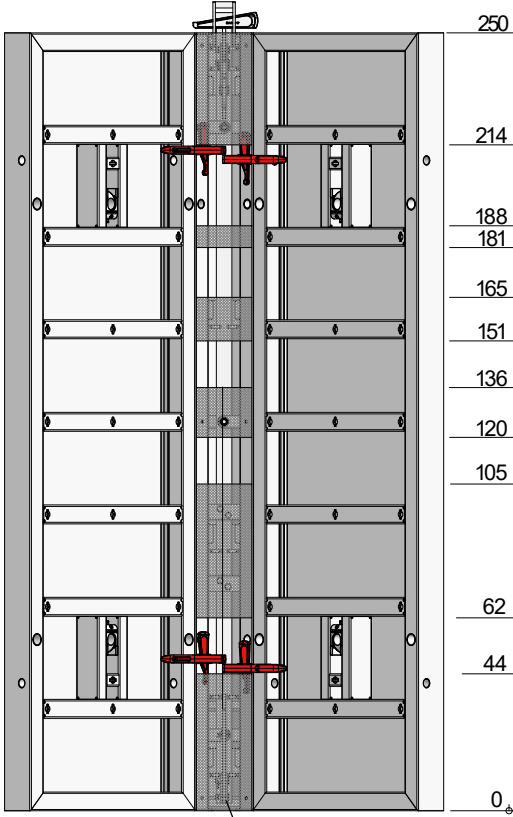


Fig. 53.1 M stripping corner 250/25

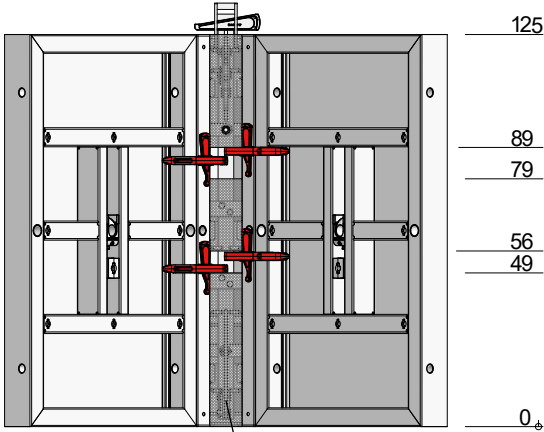
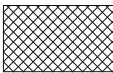


Fig. 53.2 M stripping corner 125/25



No assembly locks possible in grey shaded areas!

Description	Ref. No.
Mammut 350 SC 250/25	23-151-20
Mammut 350 SC 125/25	23-151-30

Stripping corner

Set-up and handling

1. Insert the wedge integrated into the stripping corner into the connecting device (Position C, Fig. 54.6).
2. Connect the stripping corners and panels (see pages XT-51 to -53).
3. Remove the wedges after pouring and prior to stripping.
4. Activate the stripping corner with a crowbar. The bell-crank lever is pushed upwards using the crowbar. The crowbar can be applied at the bottom at position A (Fig. 54.3) or in the middle at position B (Fig. 54.4). This breaks the bond between the formwork facing and the concrete without much effort.

Pages XT-55 and -56 describe how to activate the stripping corner with the stripping support.

5. Attach the shaft formwork with crane slings to the crane gear. Make sure the entire formwork is completely removed from the poured walls before lifting it by crane.
6. The entire formwork is moved in one single lift and detached from the crane when it is in its new position.
7. The stripping corner can be reset for the next pour by positioning the crowbar at position C (Fig. 54.5) and pushing the bell-crank lever down.
8. Reinsert the wedge into the connecting device (Fig. 54.6).
9. A few hammer blows to the wedge will move the lateral parts of the stripping corner outwards and keep them in the pouring position.

Note

Returning the stripping corner to its original position by hitting the bell-crank lever with a hammer can result in damage and is not permitted.

Height extension

Two stripping corners can be connected to each other easily by joining their bell-crank levers. The integrated pin must be secured with the cotter pin (Position D, Fig. 54.1).

Position D

Bolt with cotter pin

Bell-crank lever

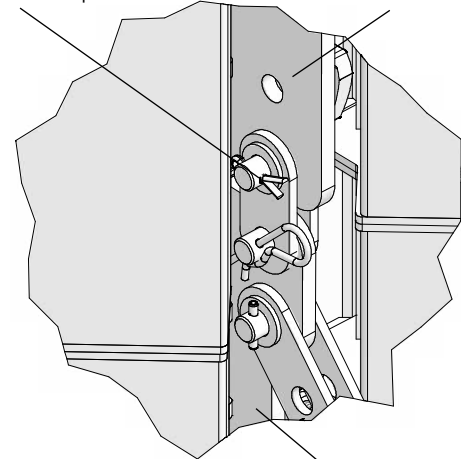


Fig. 54.1

Bell-crank lever

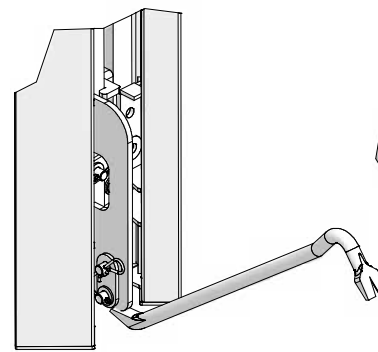
Position B


Fig. 54.3

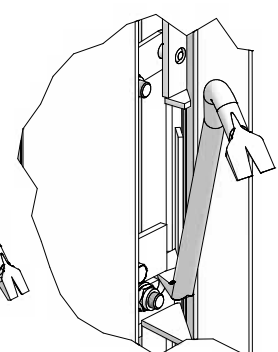
Position B


Fig. 54.4

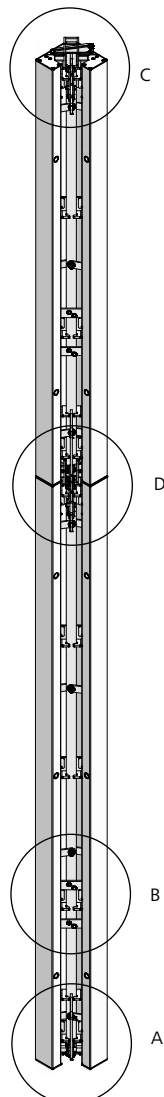


Fig. 54.2

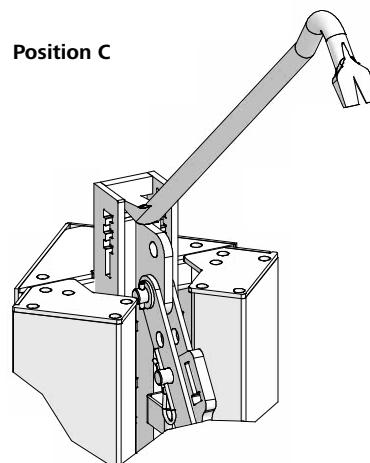
Position C


Fig. 54.5

Connecting device

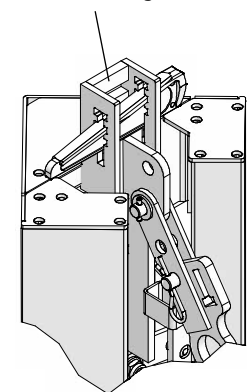


Fig. 54.6 Pouring position

Description	Ref. No.
Mammut 350 SC 350/25	23-151-00
Mammut 350 SC 300/25	23-151-10
Mammut 350 SC 250/25	23-151-20
Mammut 350 SC 125/25	23-151-30

Stripping corner

Stripping support

The stripping support (Fig. 55.1) is used to easily activate the stripping corner from above

with a power screwdriver, a ratchet spanner or a spanner. Tools with width across flats of 27, 30 or 36 mm are to be used.

Stripping corner tool

The stripping corner tool (Fig. 55.2) also enables the stripping corner to be screwed back to its original position with a power screwdriver, a ratchet spanner or a spanner. Tools with width across flats of 36 mm are to be used.

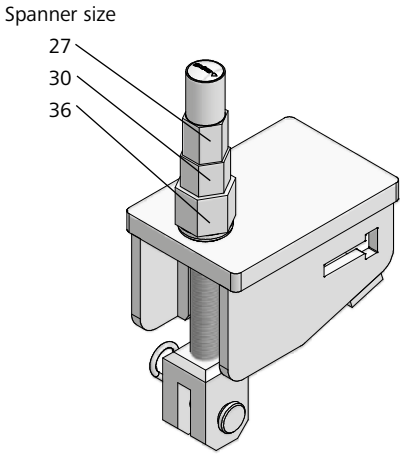


Fig. 55.1: Stripping support

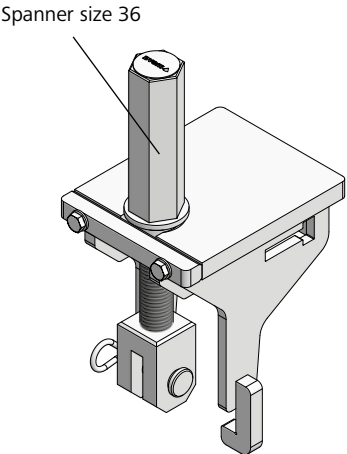


Fig. 55.2: Stripping corner tool

Assembly

1. Place the stripping support / stripping corner tool onto the connecting device at the top of the stripping corner. Make sure the suspension is inclined downwards (Fig. 55.3).
2. Connect the stripping support / stripping corner tool to the stripping corner with the head bolt 16/40 and cotter pin 4 that are both integrated into the tensioning screw of the stripping support or the stripping corner tool (Fig. 55.3).
3. Lock the stripping support / stripping corner tool to the stripping corner by driving the stripping corner's wedge with a few hammer blows into the opening on the side of the stripping support / stripping corner tool (Fig. 55.3).

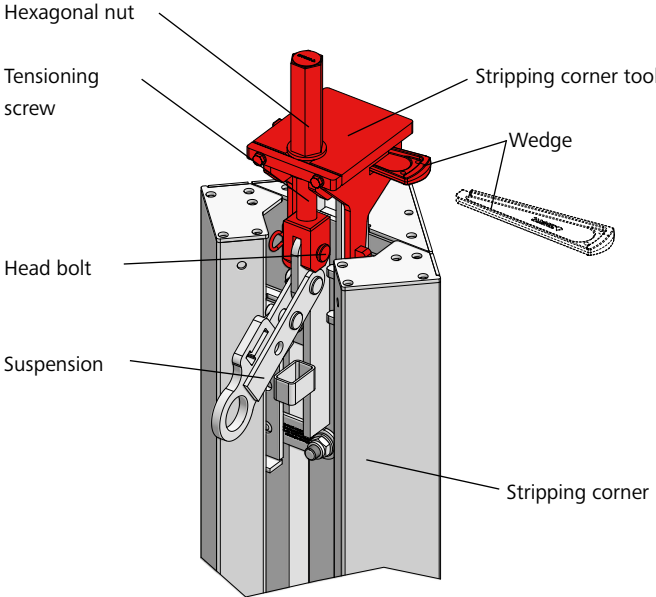


Fig. 55.3

Description	Ref. No.
Stripping support	79-306-30
Stripping corner tool	29-306-32
Spanner	
size 27	29-800-10
size 36	29-800-15

Stripping corner

Working principle of the stripping support / stripping corner tool

The stripping support has three hexagonal nuts that are operated with tools with width across flats of 27, 30 and 36 mm. The stripping corner tool has a hexagonal nut with widths across flats of 36 mm.

Turning the hexagonal nut on the tensioning screw with a power screwdriver (Fig. 56.1), a ratchet spanner (Fig. 56.2) or a spanner moves the bell-crank lever upwards (Fig. 56.5).

This activates the stripping corner and separates the shaft formwork from the poured walls (Fig. 56.4).

When the shaft formwork has been relocated, the stripping corners can be screwed back into their original position using the stripping corner tool (Fig. 56.6).

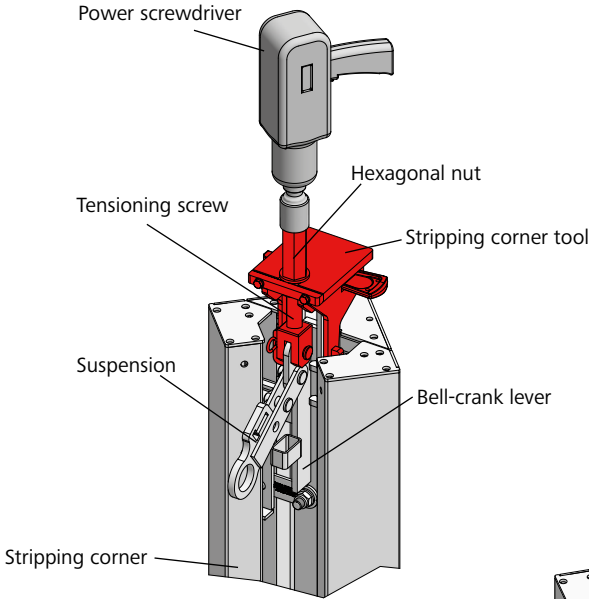


Fig. 56.1

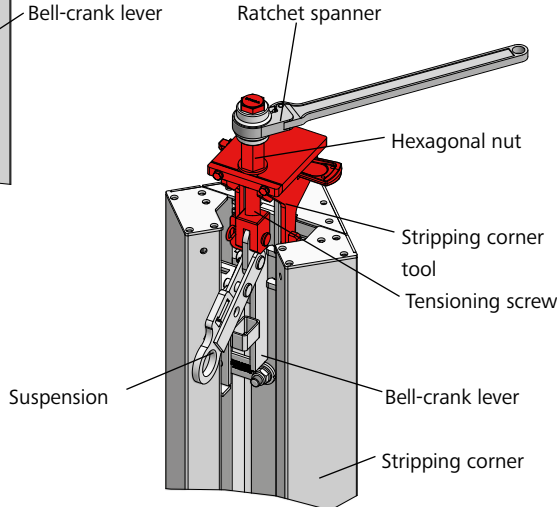


Fig. 56.2

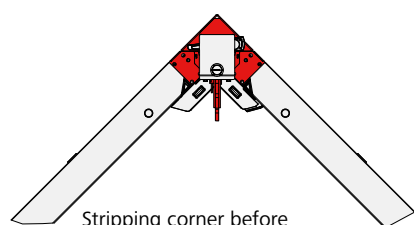


Fig. 56.3

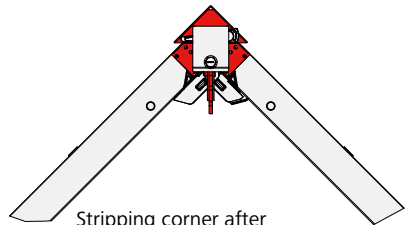


Fig. 56.4

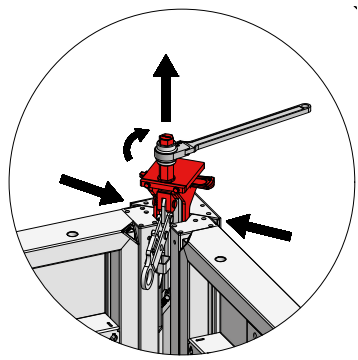


Fig. 56.5

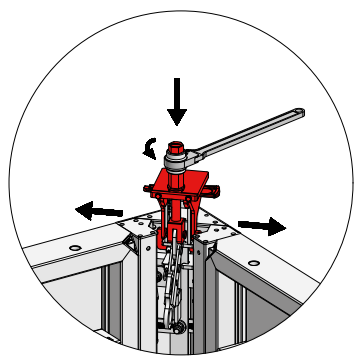


Fig. 56.6

Description	Ref. No.
Stripping support	79-306-30
Stripping corner tool.....	29-306-32
Spanner	
size 27	29-800-10
size 36	29-800-15

Stripping corner

The M stripping corner can also be used as a stripping support for panels between corners inside a room. In this case, the stripping corner is used to reduce the tension between the panels so that they can easily be removed from the poured wall between the corners.

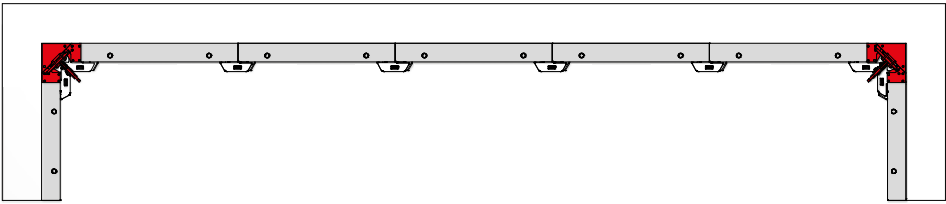


Fig. 57.1

Stripping procedure

1. Remove the M assembly locks connecting the stripping corners to the panels (Fig. 57.1).
2. Activate the M stripping corner (Fig. 57.2 and pages XT-54 to -56).
3. Lift the stripping corners off, then strip the panels (Fig. 57.3).

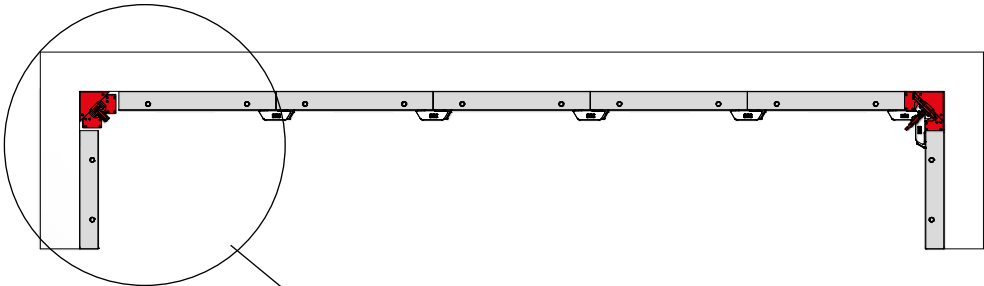


Fig. 57.2

M stripping corner has been activated

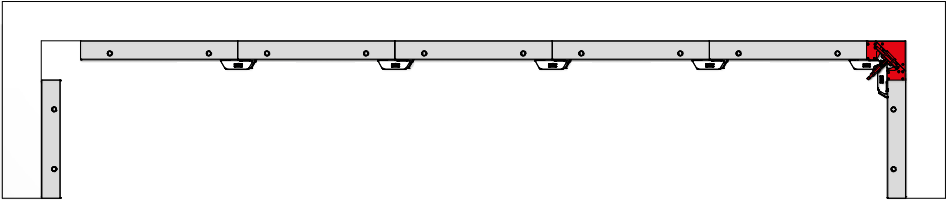


Fig. 57.3

Length compensation – Mammut XT compensation panel

Gaps of 20 to 50 cm can be compensated for with the Mammut XT compensation panel.

The compensation panel consists of two frame profiles with integrated nailing strip. The facing for the length compensation must be ordered separately in the required width and height. The facing must be 20 mm thick. We recommend using an alkus facing AL 20.

If the gap is greater than 30 cm, the compensation panel is supported in the middle with, for example, square timber and tied from both sides (Fig. 58.1).

To stiffen the compensation panel, alignment rails with flange screw 18 must be attached. The minimum number of alignment rails depends on the number of tie holes / panel height (Figures 58.1 to 58.4).

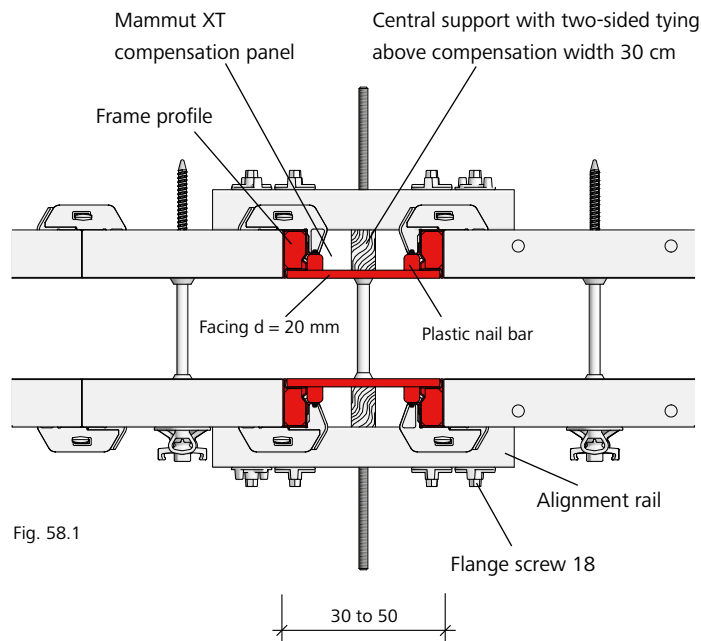


Fig. 58.1

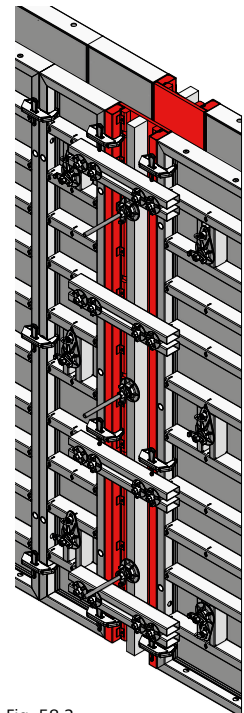


Fig. 58.2

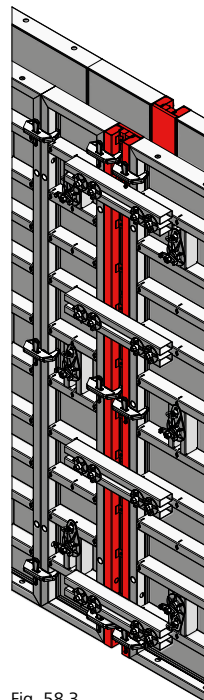


Fig. 58.3

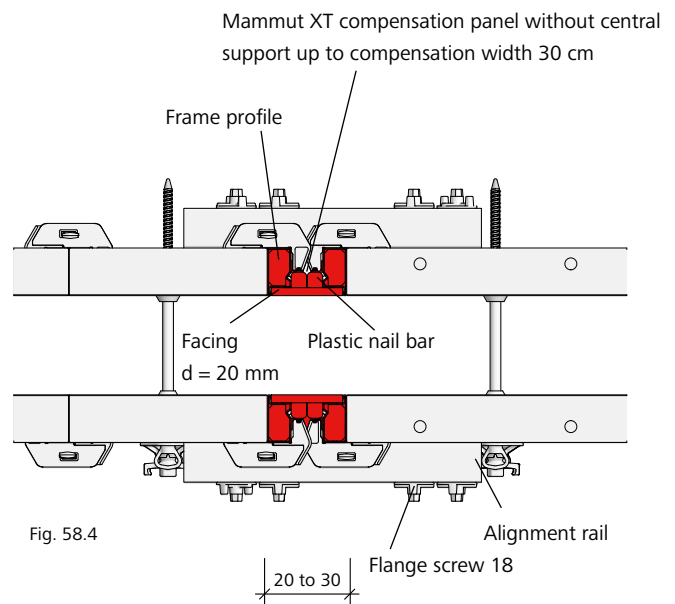


Fig. 58.4

Description	Ref. No.
XT compensation panel 350 ...	23-153-00
XT compensation panel 300 ...	23-153-05
XT compensation panel 250 ...	23-153-10
XT compensation panel 125 ...	23-153-15

Length compensation – Filler / timber filler

Timber filler

Gaps up to 10 cm can be filled using corresponding timber fillers and Uni-assembly locks 22, while for gaps up to 16 cm (Fig. 59.1) timber fillers and Uni-assembly locks 28 are used.

Timber profile

Timber profiles are used for gaps exceeding 17 cm (Figures 59.2 and 59.3). A facing is cut to size and attached to the timber profiles.

For problem areas, job-built formwork is attached to the panels using M timber profiles and M assembly locks (Figures 59.3 and 59.4).

Filler

Gaps can be closed using one or two M aluminium fillers (Fig. 59.5). In the case of two adjacent fillers, the second filler is rotated through 180°. The fillers have tie holes.

Reinforcement is achieved using alignment rails which are attached with flange screws to the multi-function profiles. The minimum number of alignment rails depends on the number of tie holes / panel height (Figures 59.1 and 59.2).

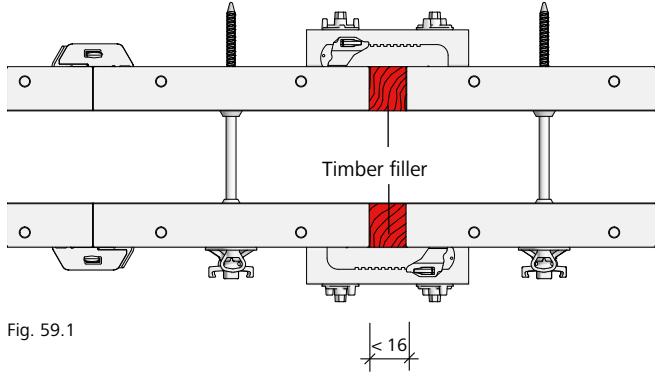


Fig. 59.1

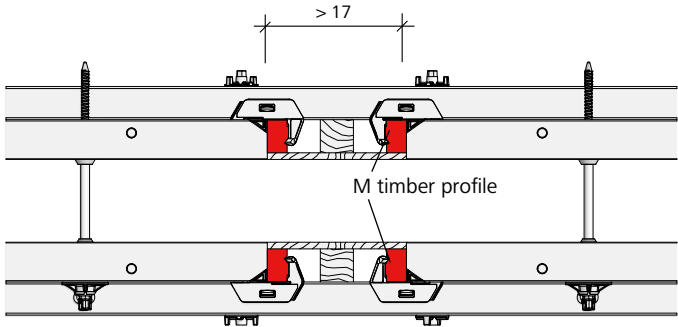


Fig. 59.2

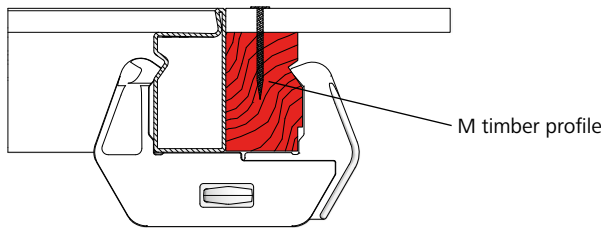


Fig. 59.3

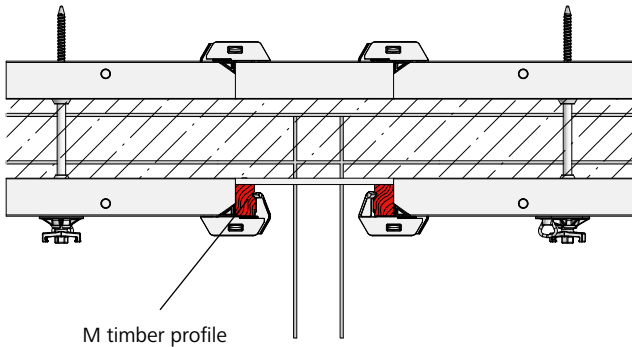


Fig. 59.4

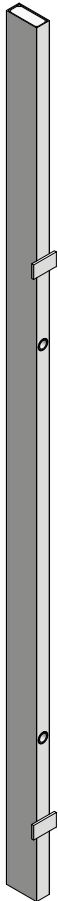


Fig. 59.5

Description	Ref. No.
Flange screw 18.....	29-401-10
Uni-assembly lock 22.....	29-400-85
Uni-assembly lock 28.....	29-400-90
M timber profile 350/21.....	29-400-02
M timber profile 300/21.....	29-400-05
M timber profile 250/21.....	29-400-15
M timber profile 125/21.....	29-400-17
M 350 aluminium filler 350/8.	29-300-27
M 350 aluminium filler 350/6.	29-300-28
M 350 aluminium filler 350/5.	29-300-30
M 350 aluminium filler 350/4.	29-300-31
M XT aluminium filler 300/8...	29-300-43
M XT aluminium filler 300/6...	29-300-44
M XT aluminium filler 300/5...	29-300-45
M XT aluminium filler 300/4...	29-300-46
M 350 aluminium filler 250/8.	29-300-33
M 350 aluminium filler 250/6.	29-300-34
M 350 aluminium filler 250/5.	29-300-35
M 350 aluminium filler 250/4.	29-300-36
M 350 aluminium filler 125/8.	29-300-38
M 350 aluminium filler 125/6.	29-300-39
M 350 aluminium filler 125/5.	29-300-40
M 350 aluminium filler 125/4.	29-300-41

Length compensation – Filler widths

The maximum filler width X for the bracing at tie hole level (Fig. 60.1) and the bracing at the multi-function profile level is determined by the permissible fresh-concrete pressure and the type of alignment rail used (Table 60.3).

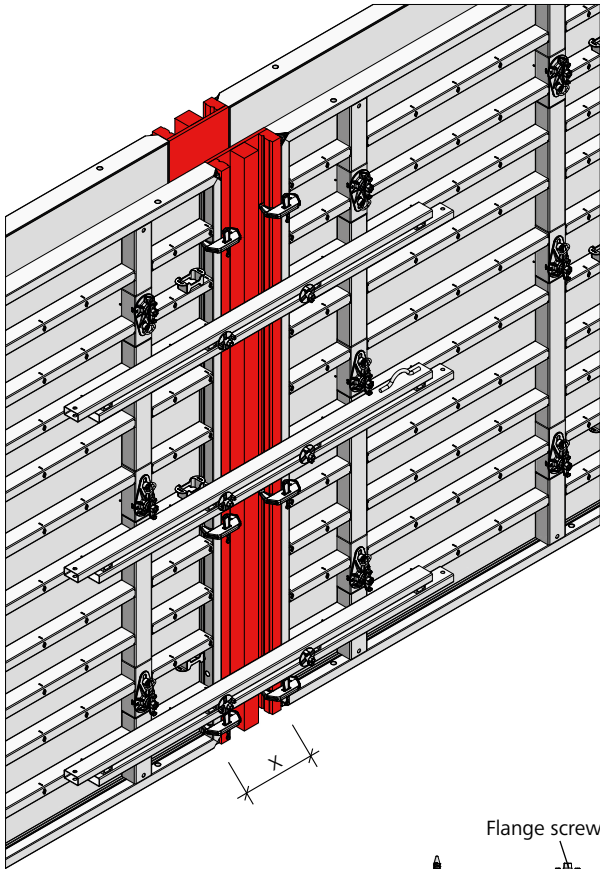


Fig. 60.1

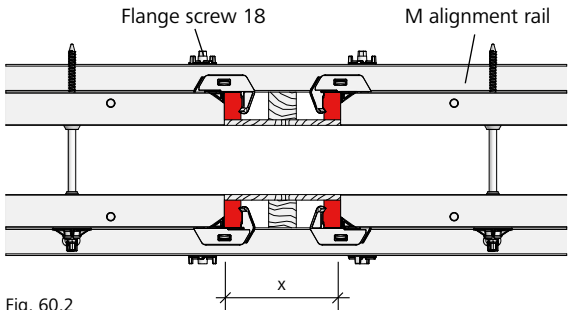


Fig. 60.2

Table to determine the permissible compensation width X depending on the bracing and permissible fresh-concrete pressure (flatness according to DIN 18202, Table 3, line 6)

Alignment rail	Cross-section	Compensation width X (cm)			
		Multi-function profile level		Tie hole level	
		70 kN/m ²	100 kN/m ²	70 kN/m ²	100 kN/m ²
M alignment rail 180	2 RR 100 x 50 x 3	100	100	80	70
M alignment rail 250		110	100*	80	70
Crossbeam 300	2 RR 100 x 60 x 4	175	145*	125	125
M alignment rail 450		175	145*	125	125
M alignment rail 450 reinforced	2 U profiles 140	265	225	200	200

Table 60.3

Description	Ref. No.
M alignment rail 450 reinforced	29-402-38
M alignment rail 450	29-402-40
M alignment rail 250	29-402-50
M alignment rail 180	29-400-92
Uni-assembly lock 22	29-400-85
Uni-assembly lock 28	29-400-90
M assembly lock	29-400-71
M cross stiffener 44	29-401-02

* refers to multiple-span beams

Wall Formwork

T wall connection

A T-wall connection can be formed using two Mammut XT inside corners (Fig. 61.1).

Depending on the wall thickness, the T-wall connection is tied from both sides through a timber filler with the corresponding thickness on the long wall opposite the inside corner and through the Mammut XT inside corner (Figures 61.1 and 61.2).

Alternatively, the connection can be made by tying in the long wall with 75 or 50 cm wide panels from both sides through the frame tie hole.

For single-sided tying, 25 cm wide Mammut XT panels are to be installed next to the inside corners (Fig. 61.3).

For the load capacity and the maximum permissible compensation widths of the alignment rails refer to page XT-60, Table 60.3.

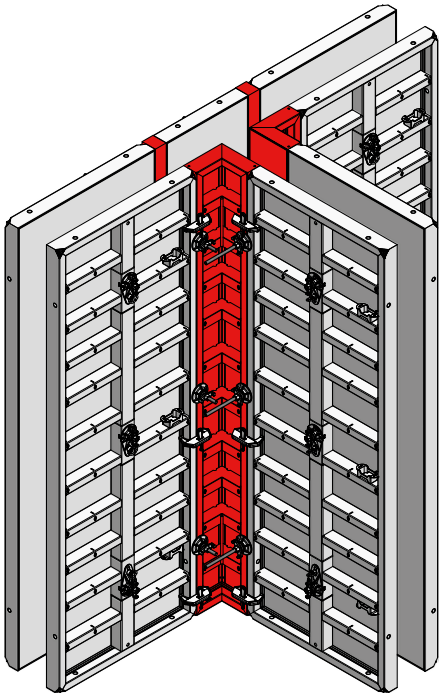


Fig. 61.1

Two-sided tying

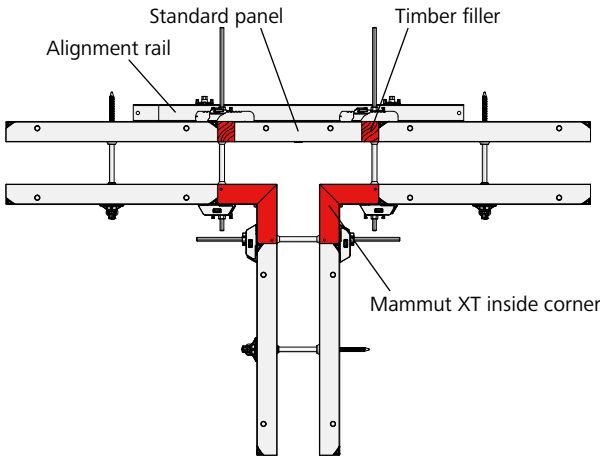


Fig. 61.2

Single-sided tying

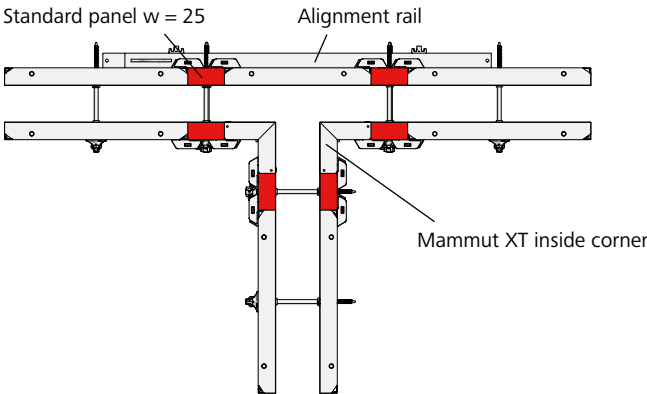


Fig. 61.3

Description	Ref. No.
M alignment rail 450 reinforced	29-402-38
M alignment rail 450	29-402-40
M alignment rail 250	29-402-50
M alignment rail 180	29-400-92
Uni-assembly lock 22	29-400-85
Uni-assembly lock 28	29-400-90
M assembly lock	29-400-71
M cross stiffener 44	29-401-02

T wall connection – Different wall thicknesses

A T-wall connection with varying wall thicknesses can be created using two Mammut XT inside corners and Mammut XT compensation panel, timber fillers or timber profiles with facings cut to size (Figures 62.1 and 62.2).

To guarantee the load capacity, the maximum permissible compensation widths of the alignment rails must be observed (see page XT-60, Table 6060.2).

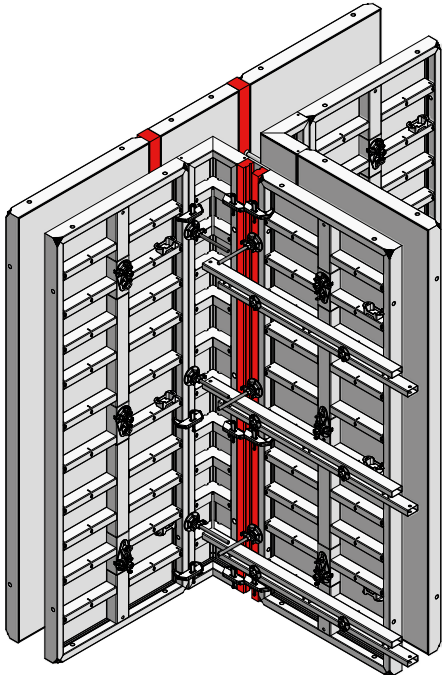


Fig. 62.1

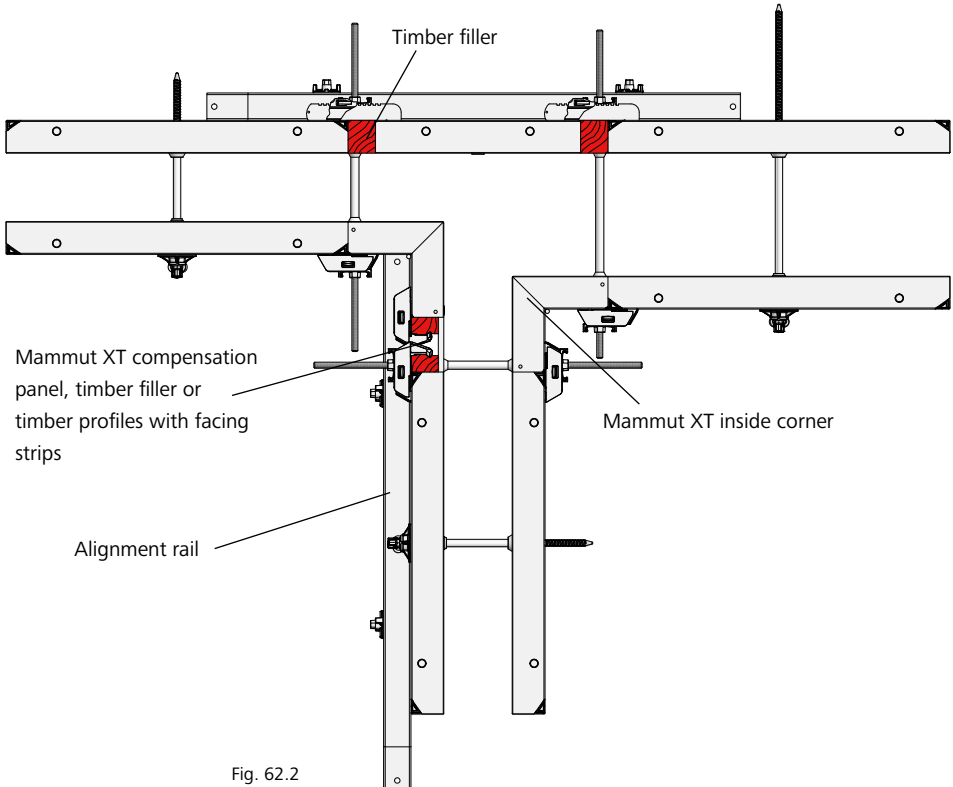


Fig. 62.2

Description	Ref. No.
M alignment rail 450 reinforced	29-402-38
M alignment rail 450	29-402-40
M alignment rail 250	29-402-50
M alignment rail 180	29-400-92
Uni-assembly lock 22	29-400-85
Uni-assembly lock 28	29-400-90
M assembly lock	29-400-71
M cross stiffener 44	29-401-02

Connection to existing walls

The panels can be connected to existing walls without problem through the internal tie holes of all Mammut XT panel widths (Figures 63.1 and 63.2).

Figures 63.3 and 63.4 show various options for connecting formwork to an existing wall. Depending on the wall layout and conditions on the construction site, the most suitable solution may vary from case to case.

Always make sure the formwork is firmly pressed up against the existing wall and attached to it without gaps in order to avoid leakage of the fresh concrete and a patchy concrete surface (Fig. 63.4).

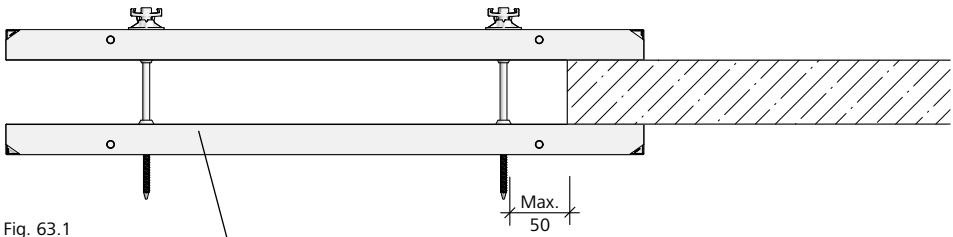


Fig. 63.1

Mammut XT large-size panel

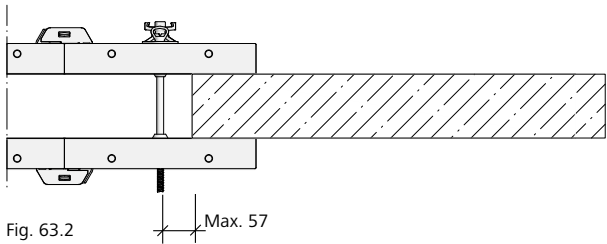


Fig. 63.2

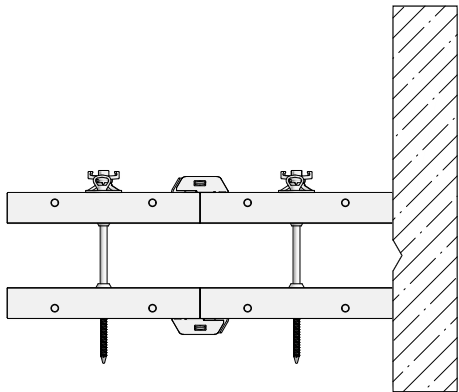


Fig. 63.3

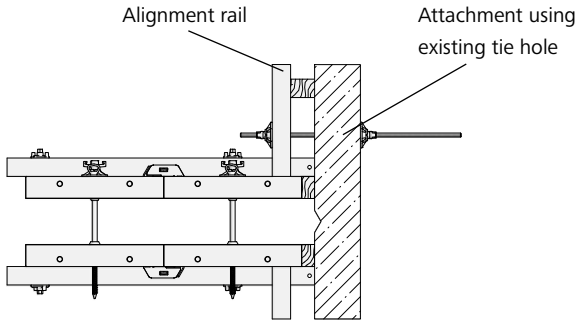


Fig. 63.4

Wall Formwork

Wall offset

Wall offsets up to 10 cm can be formed by moving back the relevant standard panel.

If the offset panel is a Mammut XT panel with a width of 75 or 50 cm, the frame tie holes can be used in addition for two-sides tying (Fig. 64.1).

For offsets from 10 to 25 cm the Mammut XT inside corner 35 should be used, and for offsets up to 30 cm the Mammut XT inside corner 40 (Fig. 64.2).

The panels are connected using job-built wooden blockings with the Uni-assembly lock 22 (Fig. 64.3).

All types of wall offset require alignment rails for reinforcement (Figures 64.1 and 64.2).

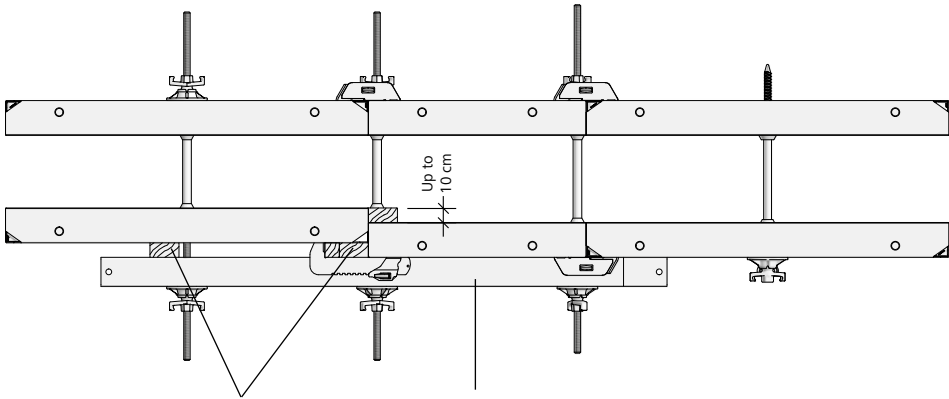


Fig. 64.1

Wooden blocking Alignment rail

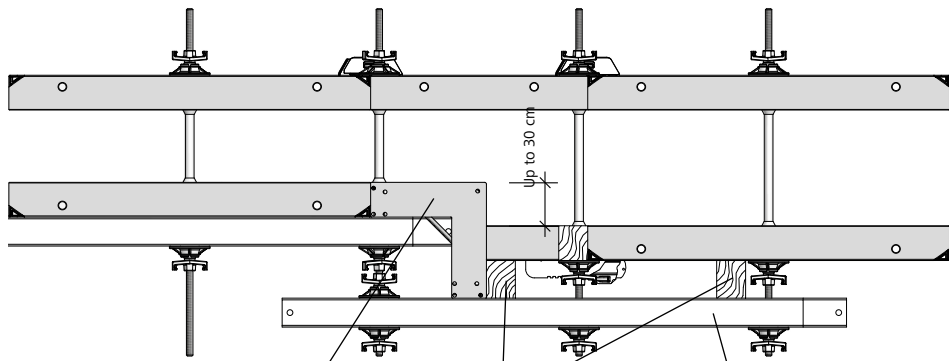


Fig. 64.2

Mammut XT inside corner Wooden blocking Alignment rail

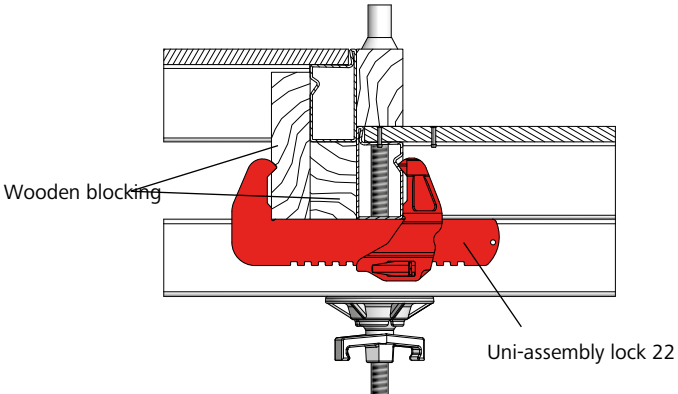


Fig. 64.3

Description	Ref. No.
M outside corner bracket.....	23-137-63
Uni-assembly lock 22.....	29-400-85
Uni-assembly lock 28.....	29-400-90

Wall Formwork

Stop ends

With outside corners and standard panels

Stop ends can also be formed using outside corners and standard panels (Figures 65.1 and 65.2).

When using Mammut XT panels with the widths 100 and 125 cm, additional alignment rails are required (Fig. 65.2). One alignment rail is required for reinforcement at each tie hole level.

For the number of assembly locks required at the outside corner and at the first panel joint refer to Table 65.3.

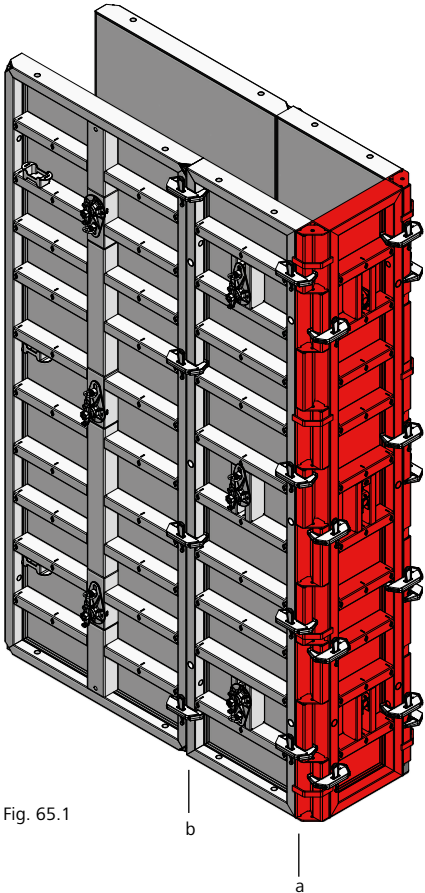


Fig. 65.1

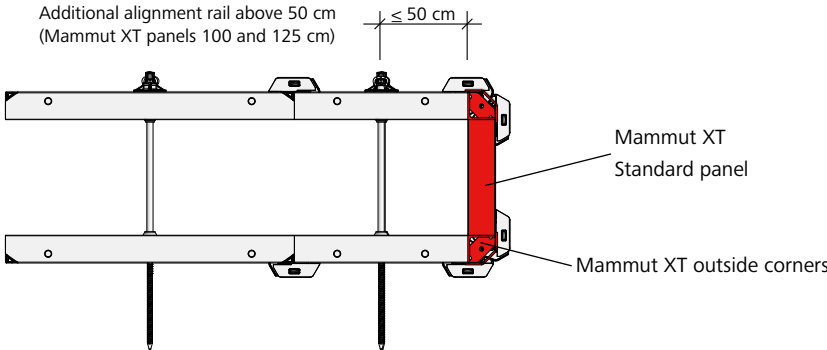


Fig. 65.2

Pouring height	Number of M assembly locks	
	Corner (a)	At panel joint (b)
h = 1.25 m	2	2
h = 2.50 m	2	2
h = 3.00 m	3	2
h = 3.50 m	4	3
h = 3.75 m	5	4
h = 4.25 m	6	5
h = 4.75 m	6	5
h = 5.00 m	6	5
h = 5.50 m	7	6
h = 6.00 m	8	7
h = 7.00 m	8	7

Table 65.3

Description	Ref. No.
M assembly lock	29-400-71

Wall Formwork

Stop ends

A stop end can be formed either with a stop end bracket, column clamp and alignment rail or a size 1 M column bracket and standard panels. The stop end bracket is placed at tie hole level and replaces the tie rod (Fig. 66.1). Round stop ends can be formed with the Circo circular steel column formwork (Fig. 66.2).

Column clamps with alignment rails are attached at tie hole level (Fig. 66.3). Panels are tied outside the panel using a Uni-tie claw and a tie rod (Fig. 66.3). Size 1 column brackets are attached to the multifunction profiles at tie hole level. The stop end can be built with square timbers and a facing (Fig. 66.4) or with standard panels that match the wall thickness (Fig. 66.5). Tying is done through the column bracket.

Attention

Never use DW tie rods for stop ends if these are going to be subject to shear stress. Tying must always be done at the column bracket.

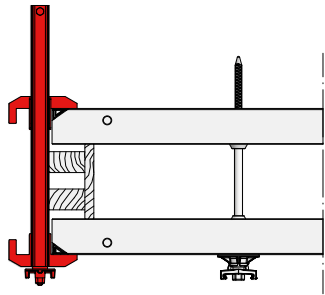


Fig. 66.1

Up to WT = 75 cm with stop end bracket 60/23 (not shown)
Up to WT = 40 cm with stop end bracket 40/60

Use M assembly lock for walls up to 60 cm thick.
From 65 cm use Circo-Mammut transition lock.

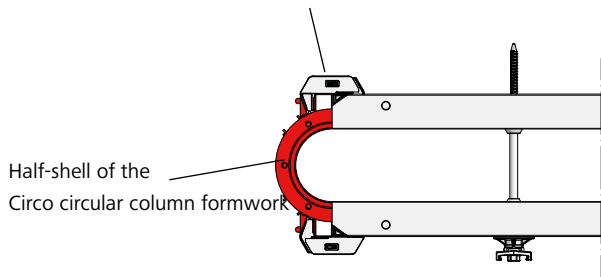


Fig. 66.2

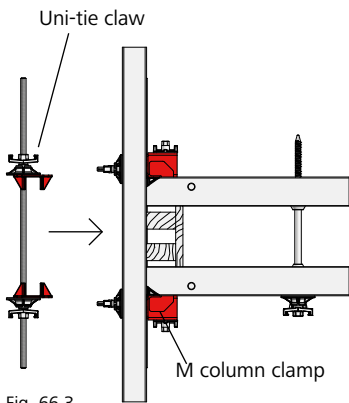


Fig. 66.3

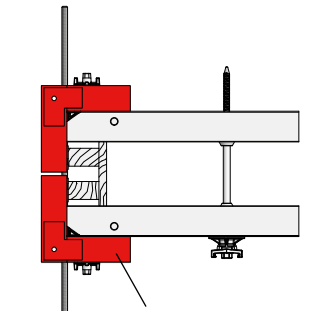


Fig. 66.4

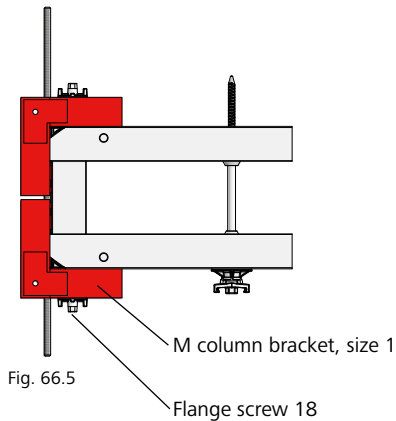


Fig. 66.5

Description	Ref. No.
Stop end bracket 60/23	29-105-60
Stop end bracket 40/60	29-105-50
M column bracket, size 1	79-402-13
M column clamp 21	29-402-70
Uni-tie claw	29-901-41
M assembly lock	29-400-71
Transition lock	
Circo-Mammut	29-400-80

Wall Formwork

Pilasters

Standard pilasters are easily formed with inside corners, standard panels and, where necessary, wooden blockings. Stop end brackets and alignment rails must be attached for reinforcement (Figures 67.1 to 67.3). Depending on the wall thickness required, timber fillers and alignment rails may also be required on the wall opposite the pilaster (Fig. 67.2).

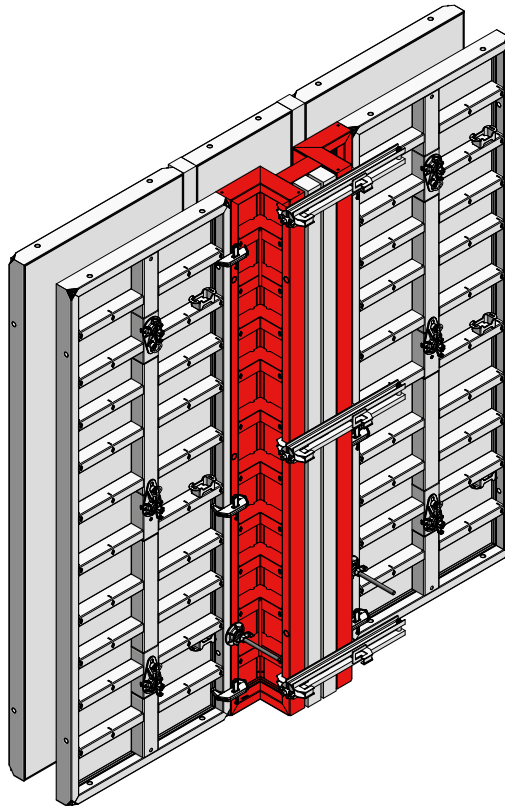


Fig. 67.1

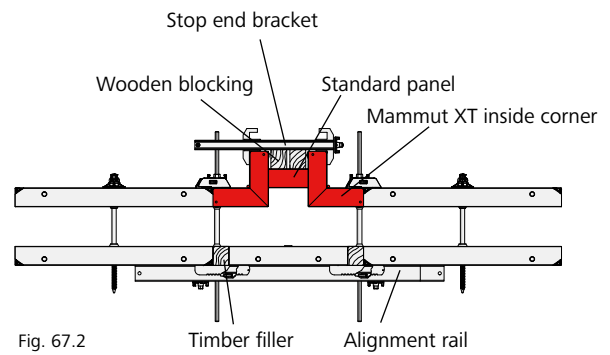


Fig. 67.2

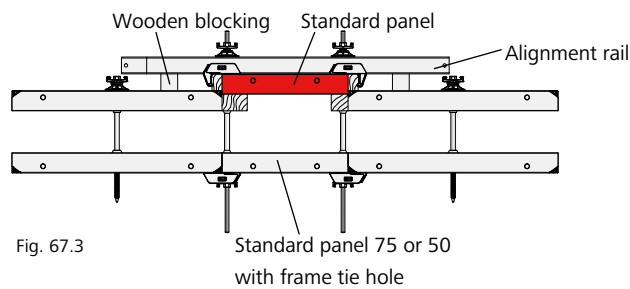


Fig. 67.3

Description	Ref. No.
Stop end bracket 40/60	29-105-50
Stop end bracket 60/23	29-105-60

Differences in height

The assembly lock can be attached at any position on the panel joint between the cross stiffeners (Fig. 68.1). The formwork's grid-free design does not require additional accessories for panel connection. Vertical, horizontal and inclined panels can all be safely and firmly connected with M assembly locks, even with differences in height.

A job-built length compensation is produced using timber profiles and an alkus facing cut to the size required or a wooden board. If required, use square timbers for reinforcing. A compensation larger than 36 cm requires a centred square timber to support the facing.

Square timbers and the facing are simply connected with M assembly locks. Pay special attention when using wood fillers (see page XT-60). It may be necessary to use alignment rails and/or wooden blockings.

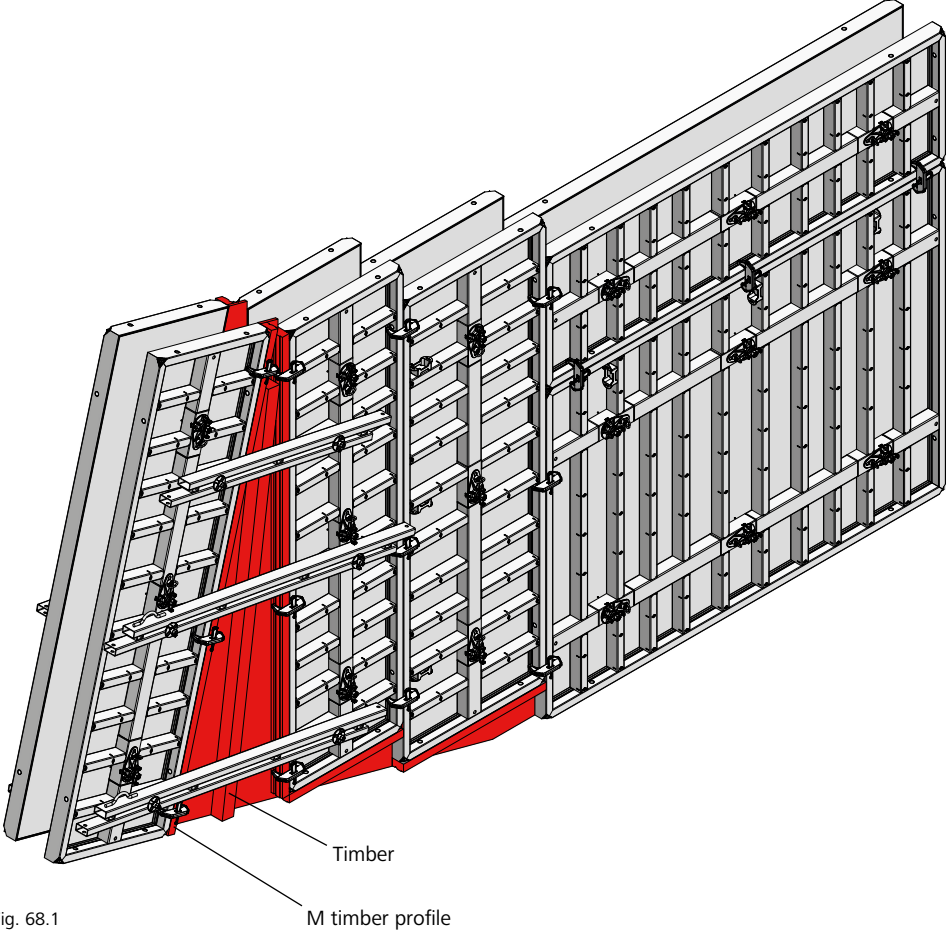


Fig. 68.1

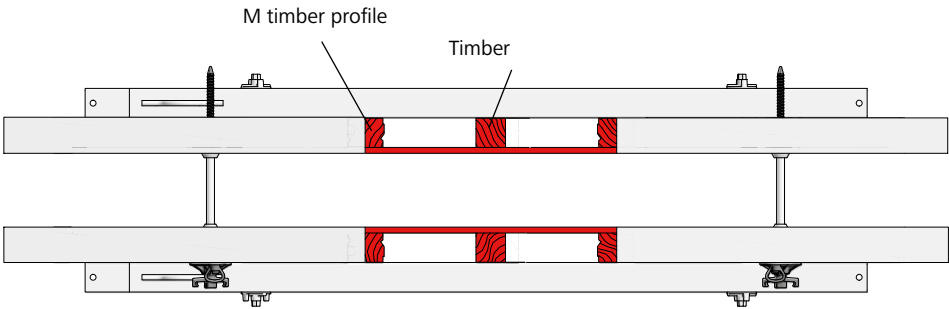


Fig. 68.2

Description	Ref. No.
Uni-assembly lock 22	29-400-85
Uni-assembly lock 28	29-400-90
M timber profile 350/21	29-400-02
M timber profile 300/21	29-400-05
M timber profile 250/21	29-400-15
M timber profile 125/21	29-400-17

Wall Formwork

Horizontal panels

Mammut XT allows a lot of forming problems to be easily solved. These include basin walls in water treatment plants, foundations and strip footings which often require a certain height.

The central tie hole allows the Mammut XT panel to be used horizontally without problem (Figures 69.1 and 69.3). To provide stability and to ensure that the wall thickness is correct in the vicinity of the top tie hole, a spacer (Fig. 69.6) or a wooden blocking may be required. The spacer is available for wall thicknesses 20, 24, 25 and 30 cm.

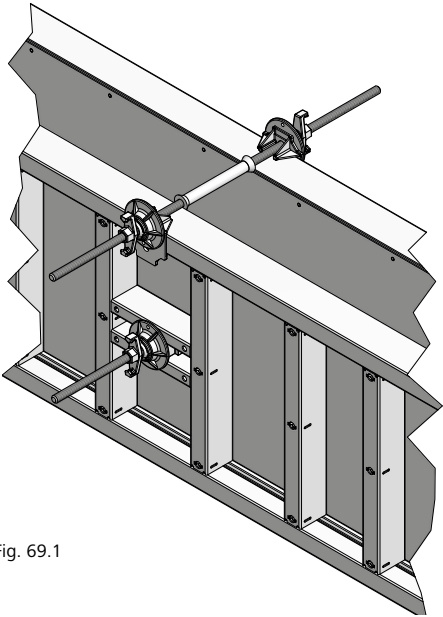


Fig. 69.1

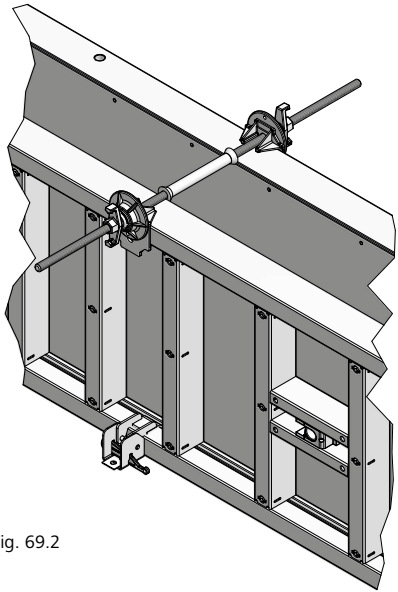


Fig. 69.2

To prevent a tie hole remaining in the component, foundation tape and tensioners can be used under the formwork panel (Figures 69.2 and 69.4). The tensioner for foundation tape is attached to the formwork using a wedge. The maximum tensioner spacing is to be observed (Table 69.5).

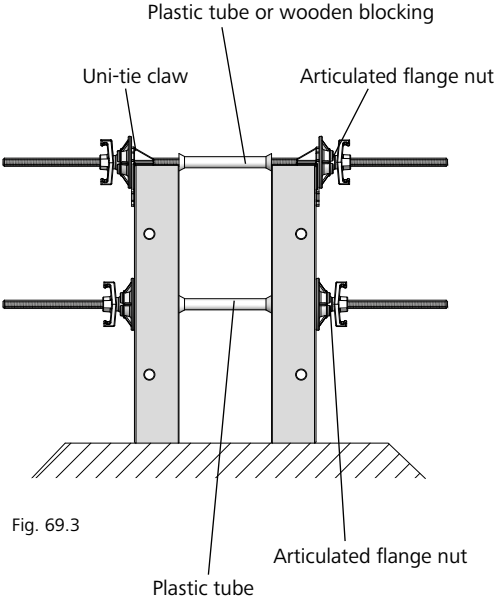


Fig. 69.3

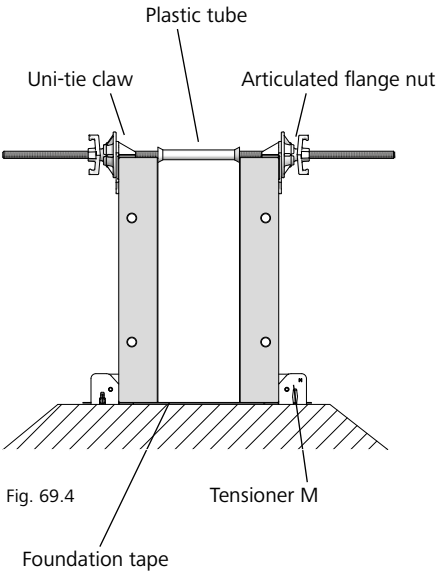


Fig. 69.4

The Uni-tie claw can be used as the top tie connection. The following is required for each tie hole:

- Two Uni-tie claws
- One tie rod DW
- Two articulated flange nuts (Figures 69.1 to 69.4) We also recommend the use of a plastic tube. It serves as a spacer and protects the tie connection against contamination.

Maximum tensioner spacing	
Pouring height 75 cm	185 cm
Pouring height 100 cm	120 cm
Pouring height 125 cm	70 cm

Table 69.5

Description	Ref. No.
Foundation tape 50 m roll	29-307-50
Tensioner M	29-307-60
Trolley for foundation tape	29-307-55
Uni-tie claw	29-901-41
Spacer 20/24 AL20/17	29-901-52
Spacer 25/30 AL20/17	29-901-62

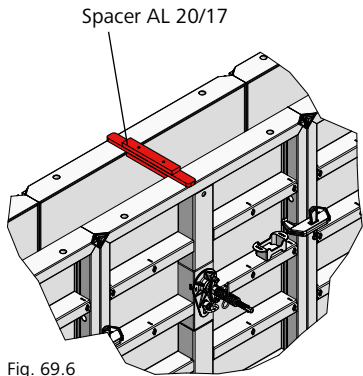


Fig. 69.6

Stabilisation of units

For an optimum load distribution, it is sensible to use large-size panels.

If three or more panels with a central tie hole (panel widths of 125 cm or less) are located next to each other, the unit is reinforced by attaching an AS alignment rail 125 to the lowest multi-function profile of the panel joint (Figures 70.1 and 70.2).

Depending on the requirements, a 90° corner can be constructed in a number of different ways. For information on these options refer to pages XT-42 ff.

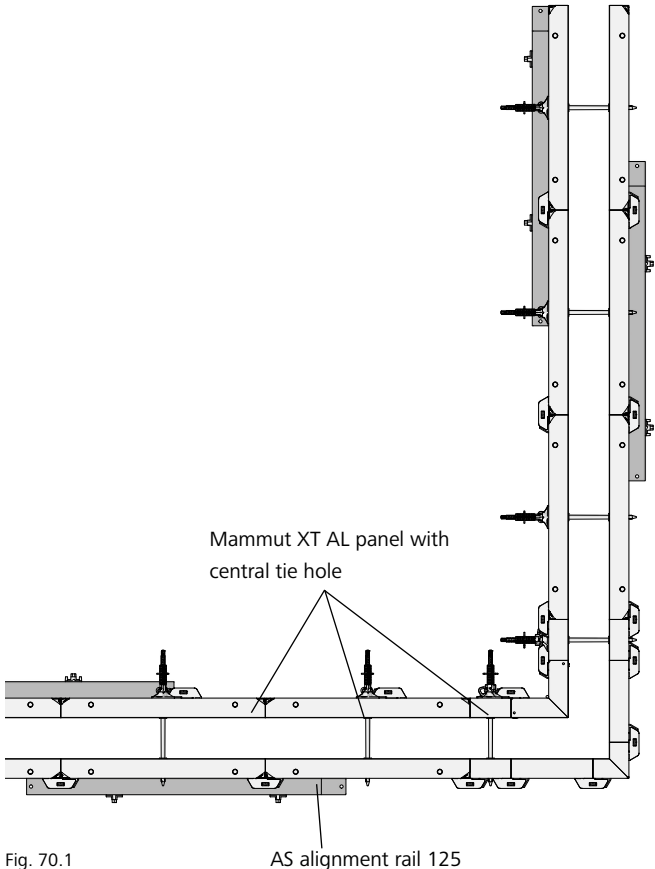


Fig. 70.1

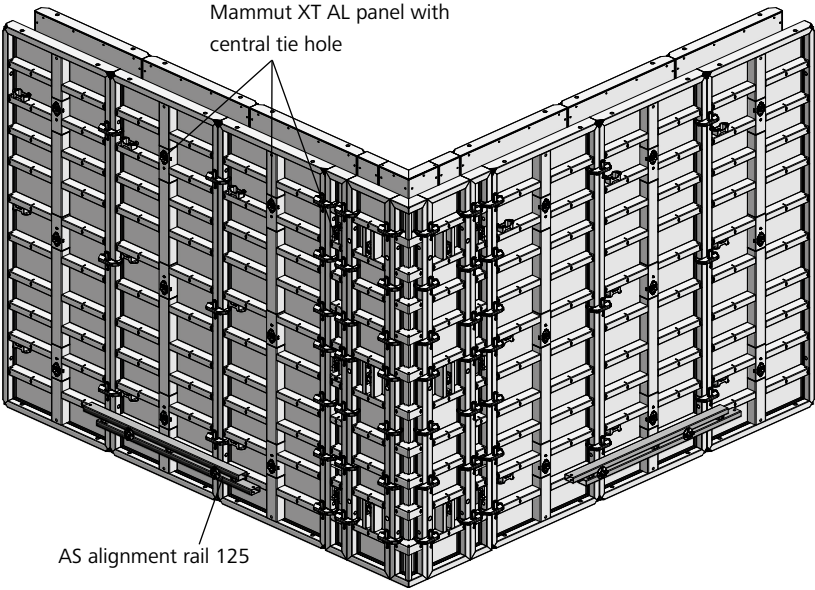


Fig. 70.2

Description	Ref. No.
AS alignment rail 125	29-201-75
Flange screw 18.....	29-401-10

Substitution of ties

In some cases tie rods can be used.

→ Panels with a height of 3.50 m do not require tying at the top tie holes if the pouring height does not exceed 3.00 m (Fig. 71.1).

→ For a pouring height up to 3.50 m, a Uni-tie claw can be attached over the panel instead of installing ties in the top tie holes (Fig. 71.2).

→ When increasing the height of the formwork with a top panel lying horizontally, no tying is required through the top panel if the top panel has a maximum width of 30 cm and if the total formwork height does not exceed 3.80 m (Fig. 71.3) provided the walkway bracket is attached to the panel below. However, if the walkway bracket is attached to the top panel, ties must be installed in its top tie holes. The Uni-tie claw in conjunction with a tie rod and a flange nut 100 can also be used to tie this configuration.

→ If the horizontal top panel for height extension has a maximum width of 1.25 m and the total formwork height does not exceed 4.75 m, the top panel does not need tying at its middle tie holes if two alignment rails RS 180 are used and the top panel is tied at the top with Uni-tie claws, tie rods and flange nuts 100 (Fig. 71.4).

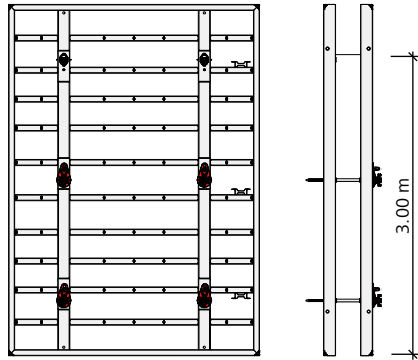


Fig. 71.1

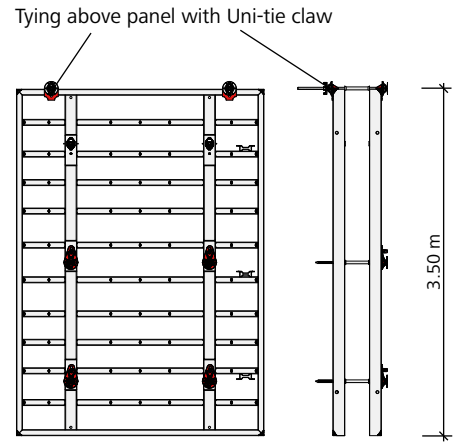


Fig. 71.2

Working platform only attached to the multi-function profile of the vertical panel

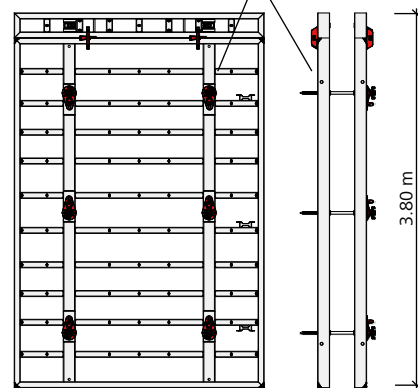


Fig. 71.3

Tying above panel with Uni-tie claw

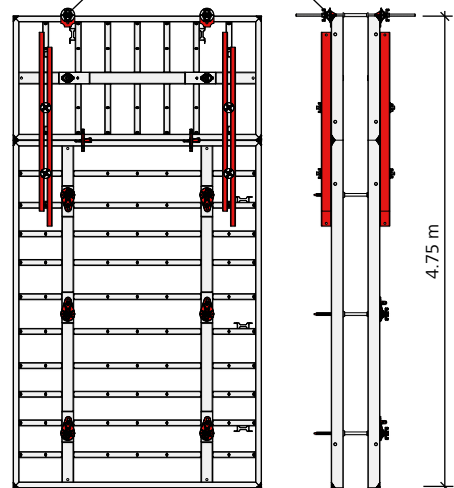


Fig. 71.4

Substitution of ties

→ When combining two vertical Mammut XT panels for a total formwork height of 7.00 m, the top ties of the top panel can be replaced by Uni-tie claws that are attached above the top panel (Fig. 72.1).

→ A formwork height of 8.25 m is achieved by extending a vertical Mammut XT panel with another vertical Mammut XT and a horizontal panel that is 1.25 m wide. Here, the middle ties of the top panel can be replaced with alignment rails and Uni-tie claws, tie rods and flange nuts 100 above the top panel (Fig. 72.2).

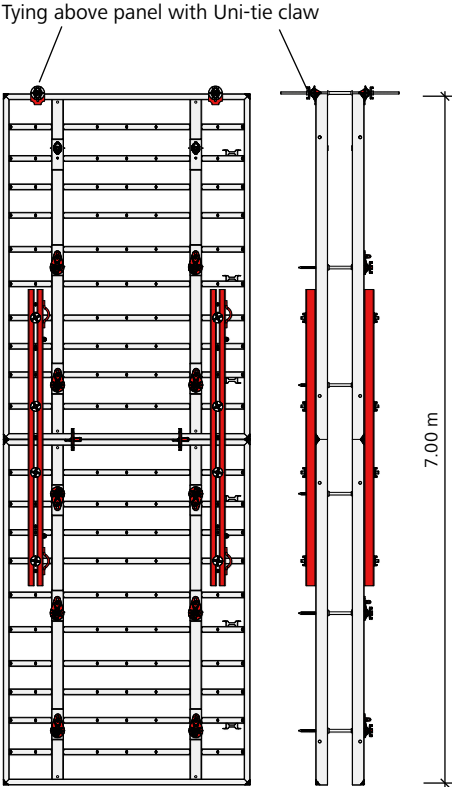


Fig. 72.1

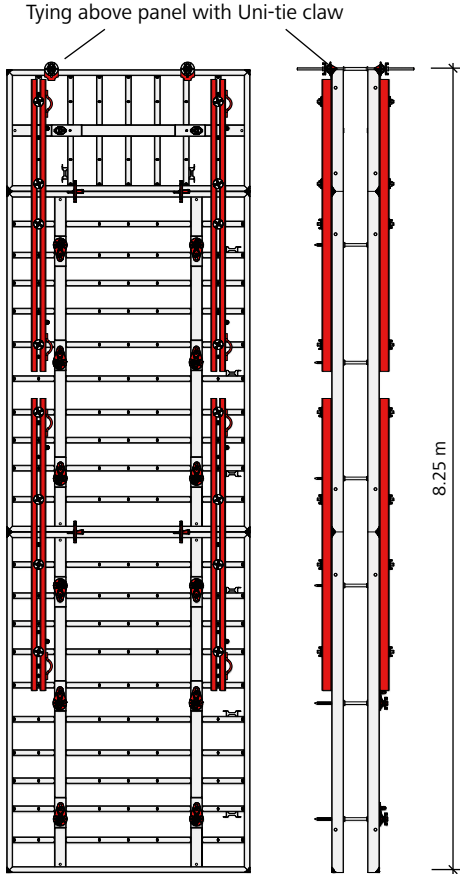


Fig. 72.2

Crane ganging

Each transport unit requires two M crane hooks with a load capacity of 15 kN (1.5 tons) attached symmetrically to the centre of gravity! The total weight of the height-extended unit depends on the load capacity of the crane hooks (Figures 73.1 to 73.3).

To ensure that the crane hooks cannot slip, they must be attached as follows:

- across the centre beam for vertical panels, if possible
- for several panels at the panel joint
- using the cross stiffeners on horizontal panels

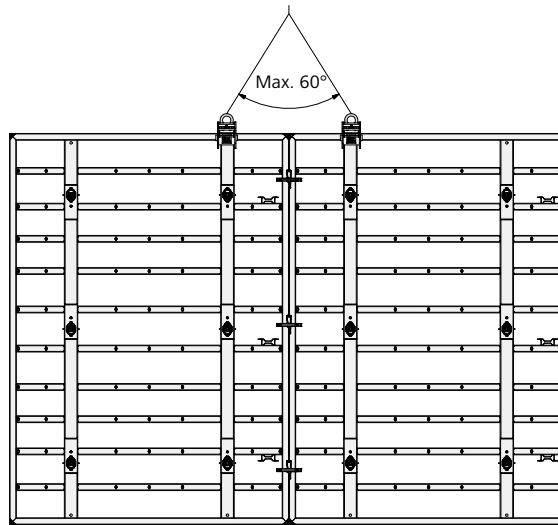


Fig. 73.1

Alignment rails are required for height extensions to stabilise the panels (Table 73.4). They are attached to the panels using flange screws 18. For heights above 10.50 m please contact our application engineering department.

Fig. 73.1

Panel unit
3.50 x 5.00 m = 17.50 m²
Weight 1103 kg

Fig. 73.2

Panel unit
7.00 m x 2.50 m = 17.50 m²
with two crossbeams 300
Weight 1228 kg

Fig. 73.3

Panel unit
4.75 m x 2.50 m = 11.88 m²
with two M alignment rails 180
Weight 834 kg

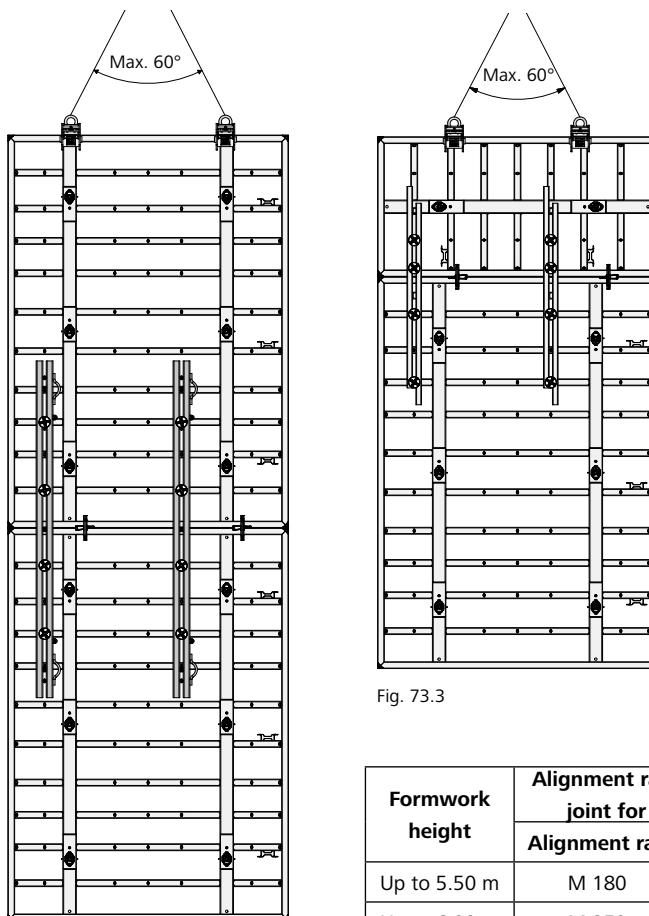


Fig. 73.3

Fig. 73.2

Formwork height	Alignment rail for each horizontal joint for a width of 1.25 m	
	Alignment rail	Quantity
Up to 5.50 m	M 180	1
Up to 6.00 m	M 250	1
Up to 10.50 m	QT 300	1

Table 73.4

Description	Ref. No.
M alignment rail 180	29-400-92
M alignment rail 250	29-402-50
Crossbeam 300	29-403-05
Flange screw 18	29-401-10

Wall Formwork

Crane ganging

Fig. 74.1

Panel unit 3.75 m x 3.50 m
= 13.13 m²
with three M alignment rails 180
Weight 947 kg

Fig. 74.2

Panel unit 7.00 m x 5.00 m
= 35.00 m²
with four crossbeams 300 and
two M cross stiffeners 44
Weight 2459 kg

Refer to page XT-73,
Table 73.4 for the type and
quantity of alignment rails
required in standard applications.
For heights above 10.50 m
please contact our application
engineering department.

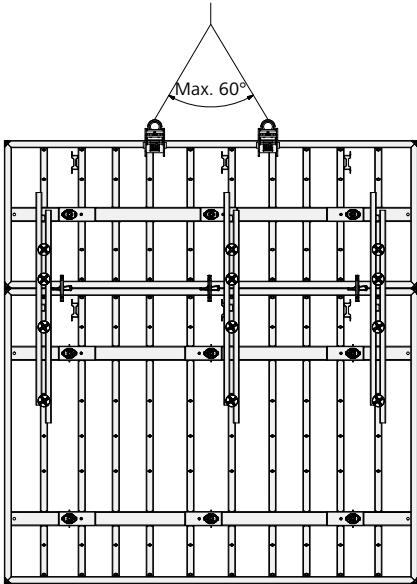


Fig. 74.1

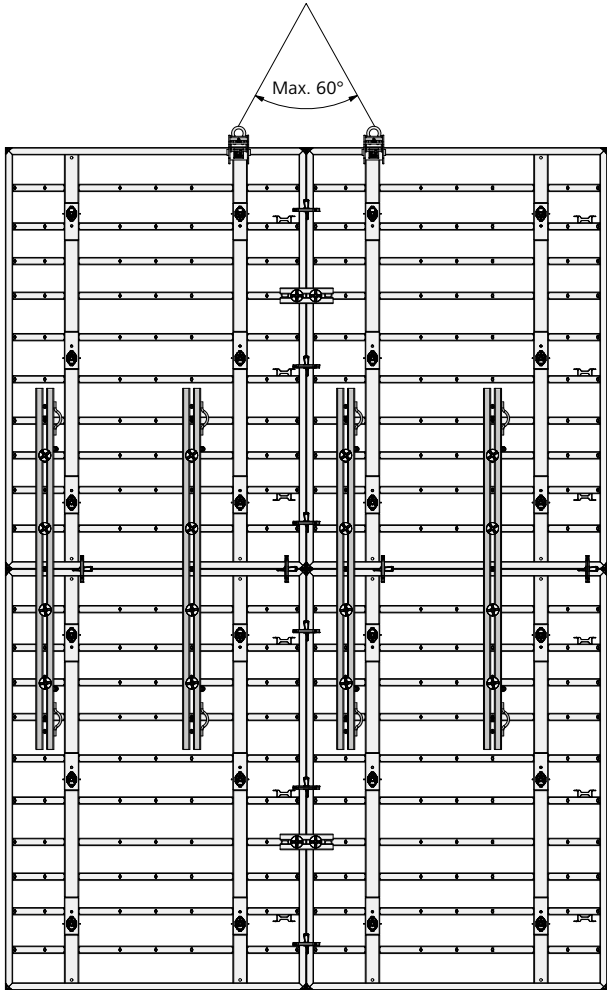


Fig. 74.2

Description	Ref. No.
M alignment rail 180	29-400-92
M alignment rail 250	29-402-50
Crossbeam 300	29-403-05
Flange screw 18	29-401-10

Column formwork – With standard panels

Columns with a maximum side length of 100 cm and a pouring height below 425 cm (Fig. 75.3) can be formed using standard panels and outside corners (Fig. 75.2).

Columns with a side length exceeding 100 cm and a minimum height of 425 cm require additional stabilisation with M alignment rails and tie rods DW 15. Refer to Table 75.1 to determine the number of alignment rails and M assembly locks for required stabilisation, depending on the pouring height and the column side length.

Each alignment rail must be attached to the panel with two flange nuts 18. Ensure that alignment rails are attached to all multi-function profiles all around the column, starting at the lowest multi-function profile (Fig. 75.4). Also observe DIN 18218 for fresh-concrete pressure and DIN 4235 for compacting concrete with a vibrator.

Pouring height (cm)	Number of alignment rails (from bottom to top) for column cross section (cm)					Number of M assembly locks
	25	50	75	100	125	
125	—	—	—	—	—	3
250	—	—	—	—	—	5
300	—	—	—	—	—	6
350	—	—	—	—	—	7
425	—	—	—	—	1	10
475	—	—	—	1	1	10
500	—	—	—	1	1	10
550	—	—	—	1	1	11
600	—	—	—	2	2	12
650	—	—	1	2	2	13
700	1	1	1	2	2	14
750	1	1	1	2	2	15
800	1	1	1	2	2	16
850	2	2	2	3	3	17
900	2	2	2	3	3	18
950	2	2	2	3	3	19

Table 75.1

Number of assembly locks required for the horizontal joints of all standard panels:

- 4 for panel width 125 cm
- 3 for panel width 100 cm
- 2 for panel widths below 100 cm

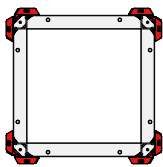


Fig. 75.2

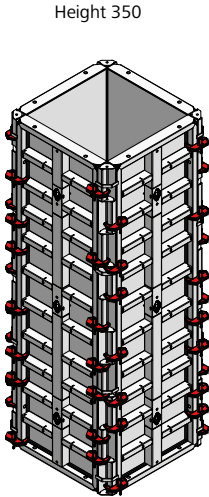


Fig. 75.3

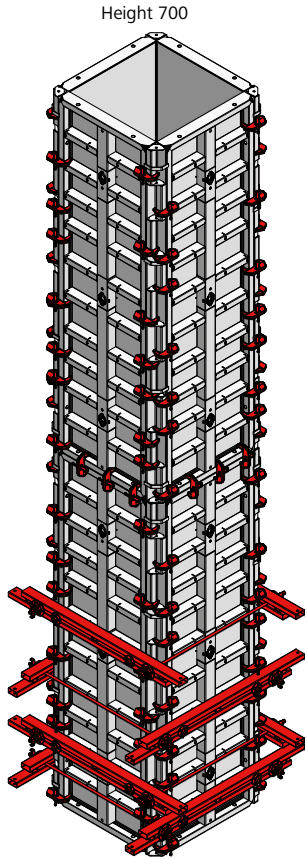


Fig. 75.4

Closing the tie holes

The tie holes in the concrete are closed using the XT plug D46 (Figures 76.1 and 76.2). It is made of plastic and is suitable irrespective of whether the XT tie rod DW or the XT taper tie was used (see page XT-16) and irrespective of whether the XT sealing cone 5 AL20 or the XT sealing cone 10 AL20 was used (see page XT-18).

For architectural-concrete requirements, the XT fibre concrete plug 47 x 8.5 is used to close the holes in the concrete (Figures 76.3 and 76.4). It is glued in place using concrete glue.

To do this, the XT sealing cone 5 AL20 preinstalled in the formwork panel must be replaced with the XT sealing cone 10 AL20 before pouring.

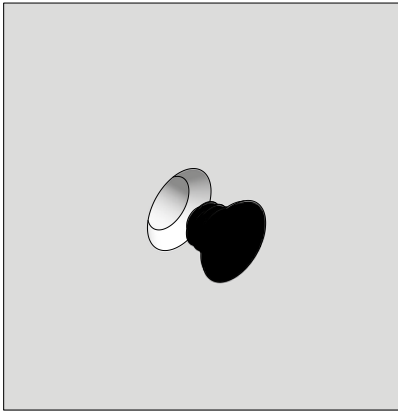


Fig. 76.1

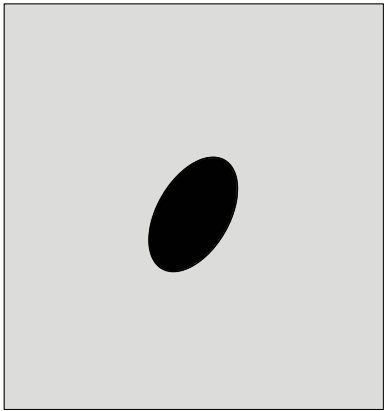


Fig. 76.2

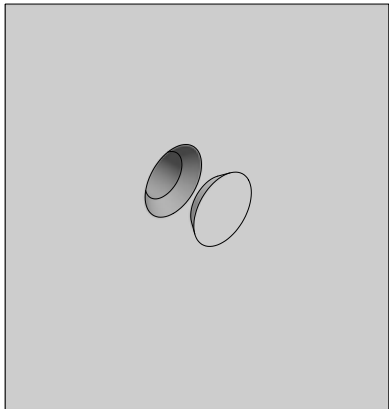


Fig. 76.3

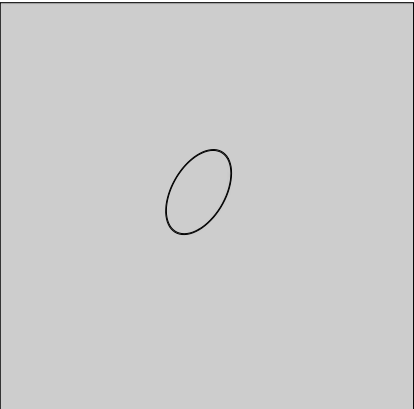


Fig. 76.4

Description	Ref. No.
XT plug D46	29-902-81
XT fibre concrete plug 47 x 8.5	29-902-82
Concrete glue (A + B)	53-210-70
XT sealing cone 5 AL20	29-902-34
XT sealing cone 10 AL20	29-902-35

Sealing the tie holes

To seal the tie holes against water pressure, the following can be used:

- FB active stop XT 20 (Fig. 77.1 and page XT-78), consisting of a tapered fibre-reinforced concrete core and an integrated expansion seal, or
- MEVA multi-stop 23 (Fig. 77.2 and page XT-79), material: TPE – thermoplastic elastomer

Test reports are available for both sealing methods.

Note

- The previous use of the tying method with XT taper tie is the prerequisite for the use of these sealing methods.
- The seal must always be installed on the wall side on which the water emerges. This is generally the outside of the wall (initial-formwork side).
- The sealing of the tie holes does not depend on the weather conditions.

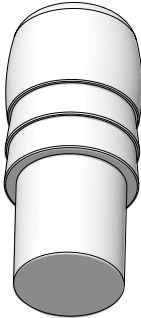


Fig. 77.1



Fig. 77.2

Seal	Sealing against hydrostatic pressure	XT taper tie 20	XT taper tie 23
FB active stop 20	5 bar (50-meter water column)	Yes	No
MEVA Multi-Stop 23	Recommended continuous pressure of 1.0 bar (= 10-meter water column) with a maximum short-term peak pressure of 1.8 bar (= 18-meter water column) (t < 1 d), short-term water pressure of 4.0 bar (= 40-meter water column) Resistant, inter alia, to salt water, diesel, bitumen and caustic soda lye.	No	Yes

Table 77.3

Description	Ref. No.
FB active stop XT 20 set.....	29-902-41
MEVA multi-stop 23.....	29-902-43

Sealing the tie holes – FB active stop XT 20

Can be used in conjunction with XT sealing cone 5 AL20 or XT sealing cone 10 AL20.

Installation of the FB active stop XT 20:

1. Clean the tie hole. It must be free of contamination and grease and have a smooth surface (Fig. 78.2).

2. Moisten the FB active stop, insert it from the final-formwork side (large tie hole diameter) with the end with the integrated expansion seal first, then hit it with a rubber mallet until it is flush.

3. Drive the FB active stop in further using the hammering aid (delivered with the FB active stop XT 20 set) and hammer (Fig. 78.4). To enable the FB active stop to be positioned correctly in the tie hole, the hammering aid has marker rings for the wall thicknesses 15, 20, 24, 25 and 30 cm. For this purpose, it is shortened at the marker ring corresponding to the desired wall thickness. The hammering aid must be driven in up to the stop (Fig. 78.4).

If the wall thickness differs from those listed above, the required length of the hammering aid can be calculated using the following formula:

Wall thickness (in cm) - 6.7 cm
(see example below).

4. Remove the hammering aid and plug the tie hole (Fig. 78.5 and page XT-76).

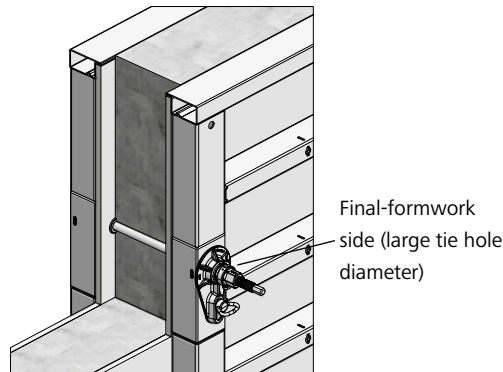


Fig. 78.1

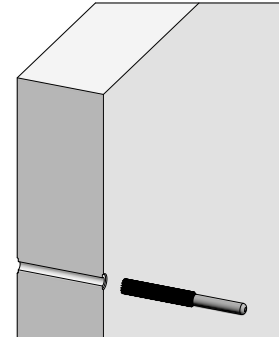


Fig. 78.2

Marker rings for wall thickness:

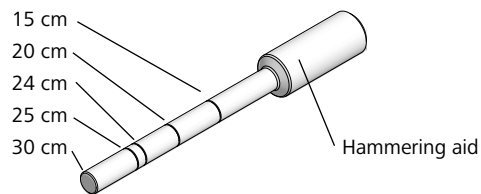


Fig. 78.3

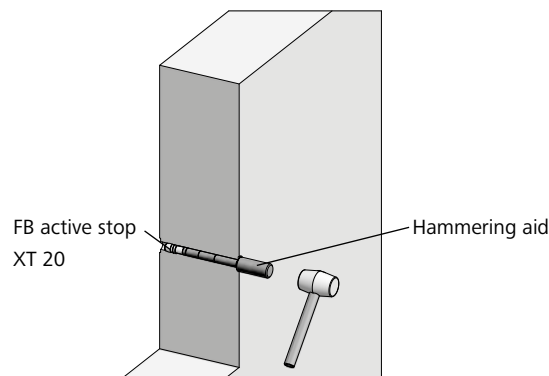


Fig. 78.4

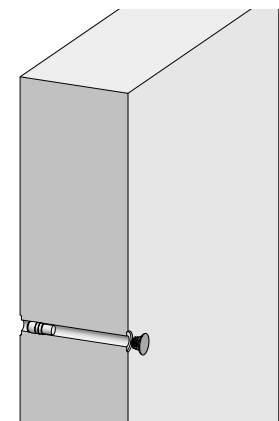


Fig. 78.5

Calculation of a different hammering aid length (e.g. wall thickness 30 cm):

Length of FB active stop XT 20 = 5.7 cm

Insertion depth of XT sealing cone = max. 1 cm

Different hammering aid length = 30 cm - (5.7 cm + 1 cm) = 23.3 cm

Description	Ref. No.
FB active stop XT 20 set.....	29-902-41

Sealing the tie holes – MEVA multi-stop 23

Can be used in conjunction with XT sealing cone 5 AL20 as well as XT sealing cone 10 AL20.

The following is required for assembly (Fig. 79.1):

- Cleaning brush
- MEVA hammering aid
- Cotter pin
- Hammer (1000 g)



Fig. 79.1



Fig. 79.2

Installation of the MEVA multi-stop 23:

1. Remove dirt and dust from the tie hole using the cleaning brush (Fig. 79.2).

2. Insert the MEVA multi-stop 23 into the tie hole (Fig. 79.3).



Fig. 79.3

3. Adjust the hammering aid to suit the wall thickness. To do this, insert the cotter pin into the corresponding hole (Fig. 79.4).



Fig. 79.4

4. Push the MEVA multi-stop 23 into the tie hole using the hammering aid (Fig. 79.5).



Fig. 79.5

5. Using the hammering aid, drive the MEVA multi-stop 23 into the tie hole (Fig. 79.6).



Fig. 79.6

6. Drive the hammering aid in until the cotter pin is up against the wall (Fig. 79.7).



Fig. 79.7

The MEVA multi-stop 23 is now in the correct position (Fig. 79.8).

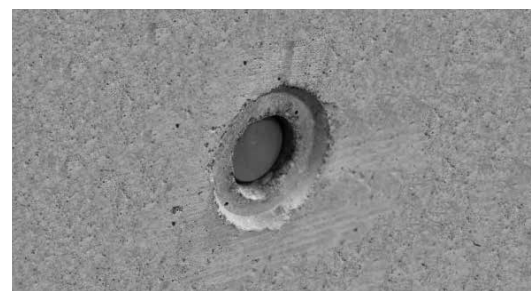


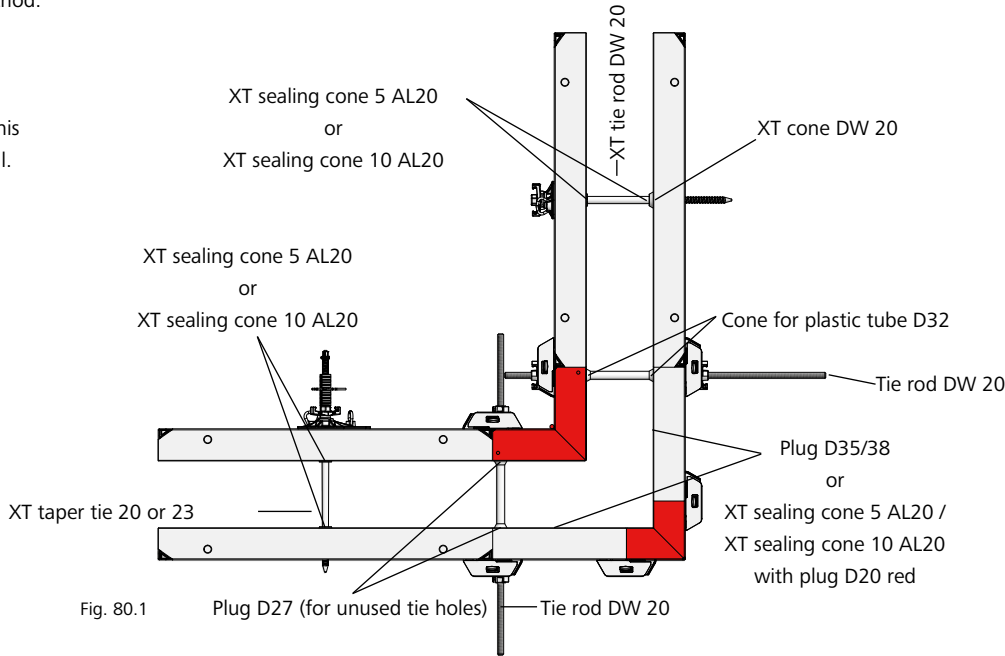
Fig. 79.8

Description	Ref. No.
MEVA multi-stop 23.....	29-902-43
MEVA multi-stop hammering aid	29-306-25

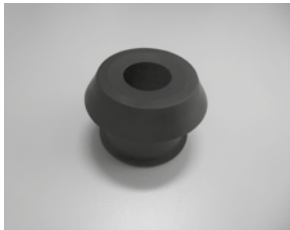
Overview of cones and plugs

The following overview lists all cones and plugs that are used depending on the tying method.

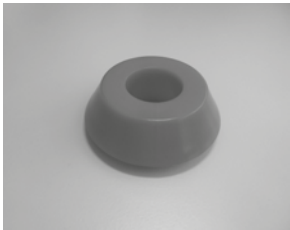
For detailed information about their use refer to the corresponding chapters in this Technical Instruction Manual.



XT sealing cone 5 AL20
29-902-34



XT sealing cone 10 AL20
29-902-35



XT cone DW 20
29-902-37



Plug D35/38
29-902-71



Plug D27
29-902-61



Plug D20 red
29-902-63

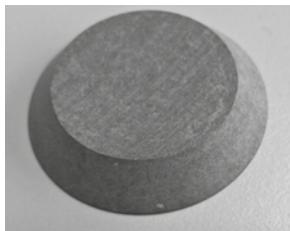
Description	Ref. No.
XT sealing cone 5 AL20	29-902-34
XT sealing cone 10 AL20	29-902-35
XT cone DW 20	29-902-37
Plug D35/38	29-902-71
Plug D35/38 without imprint ..	29-902-72
Plug D27/30	29-902-61
Plug D27/30 without imprint .	29-902-67
Plug D27 without imprint, flat.....	29-902-68
Plug D20, red.....	29-902-63
Plug D20, red without imprint	29-902-62
XT plug D46	29-902-81
Plug D32	29-902-58
XT fibre concrete plug 47 x 8.5	29-902-82



XT sealing plug D46
29-902-81



Plug D32
29-902-58



XT fibre concrete plug 47 x 8.5
29-902-82

Transport with lifting hook

The lifting hook 60 (Fig. 81.1) can be used with any 4-rope crane sling on the construction site to transport horizontal panels or panel stacks (Fig. 81.2). Always use four hooks at once. To calculate the permissible load-bearing capacity, assume that only two hooks are used.

Attention

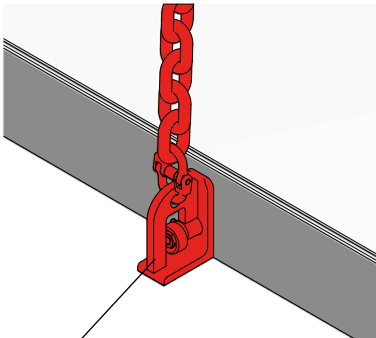
A lifting hook must only be used if its eccentric is easy to turn or falls automatically into the locked position (Fig. 81.4). Never use a lifting hook if you need force to turn its eccentric. Turning the eccentric with force may not lock the lifting hook but only make it appear to be in the locked position. This may cause the lifting hook to slip out when lifting the panel stack.

Technical data

- Weight 2.0 kg per lifting hook
- Max. load 10 kN (1 ton) per lifting hook
- Max. load 20 kN (2 tons) per panel stack
- Max. stack height: three Mammut XT panels 350/250 or ten Mammut XT panels with a maximum width of 125 cm.

Repositioning

When moving panel stacks, make sure the panels are secured against sliding (see page XT-84).



Lifting hook

Fig. 81.1

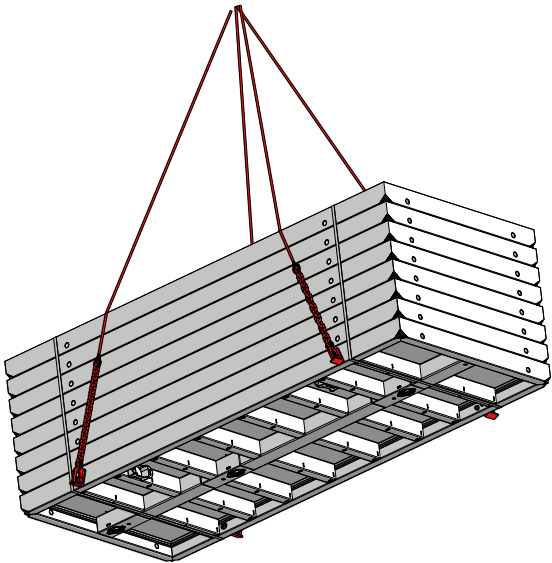
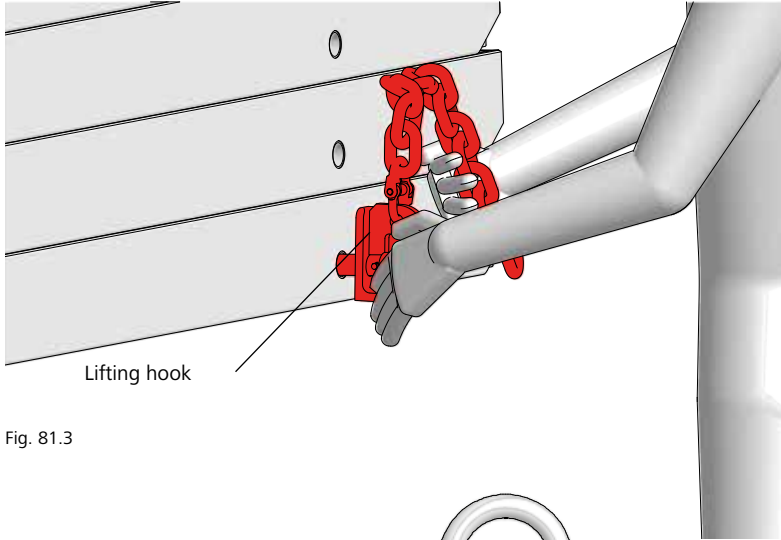
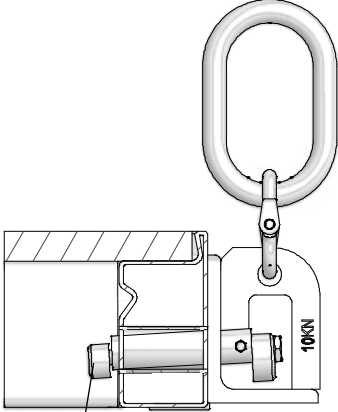


Fig. 81.2



Lifting hook

Fig. 81.3



Eccentric in locked position

Fig. 81.4

Description	Ref. No.
Lifting hook 60	29-401-40

Transport with stacking angle 60/40/23

Stacking angle 60/40/23

With the stacking angle (Fig. 82.1) made of galvanized steel, two to five wall formwork panels of the same size with frame profile widths of 60 mm, 40 mm or 23 mm can be stacked and transported using a lift/pallet truck or a crane.

To use the stacking angle with Mammut XT, the adjustable bracket on the stacking angle must be adjusted to suit the panel frame width of 60 mm (reference dimension = 64 mm) and attached using the two integrated M8 countersunk bolts with hexagonal nuts (Fig. 82.2).

Four stacking angles 60/40/23 are required for each panel stack (Fig. 82.3).

A maximum of three stacking units may be stacked one of top of the other for storage purposes (Fig. 82.3).

The permissible load capacity is:

- 15 kN (1.5 t) per stacking angle.
- 30 kN (3 t) when using four stacking angles (total load capacity).
- 45 kN (4.5 t) when using four stacking angles (total load capacity) if it has been ensured that the load is distributed evenly over further strands or if the permissible loading of the individual strands is not exceeded in the event of an unequal load distribution.

Assembly

1. Insert a stacking angle 60/40/23 at each corner of the Mammut XT panel so that the panel lies on the supporting surface with the facing side upwards. This protects the facing when it is being moved by a forklift truck.
2. Insert the next panel into the adjustable brackets from above. The second panel secures the stack, which can now be moved.
3. If required, insert further panels (up to a total of five).

Note

- A 4-rope crane sling must always be used when transporting using a crane.
- The opening angle of the crane sling must not exceed 60° (Fig. 82.4).
- Observe the operating instructions for the stacking angle 60/40/23.

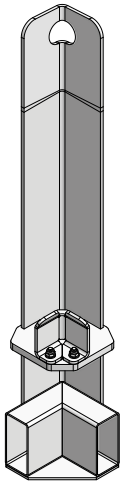


Fig. 82.1

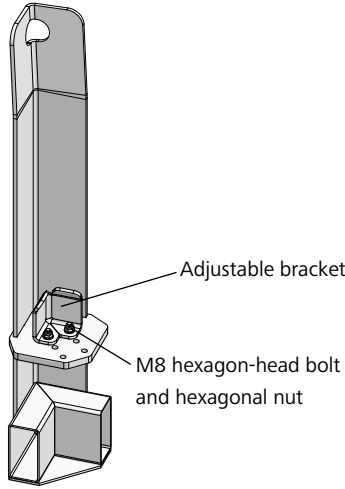


Fig. 82.2

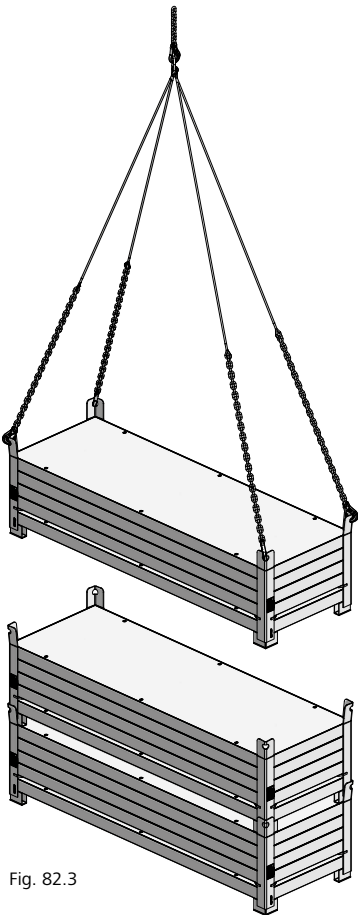
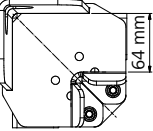


Fig. 82.3

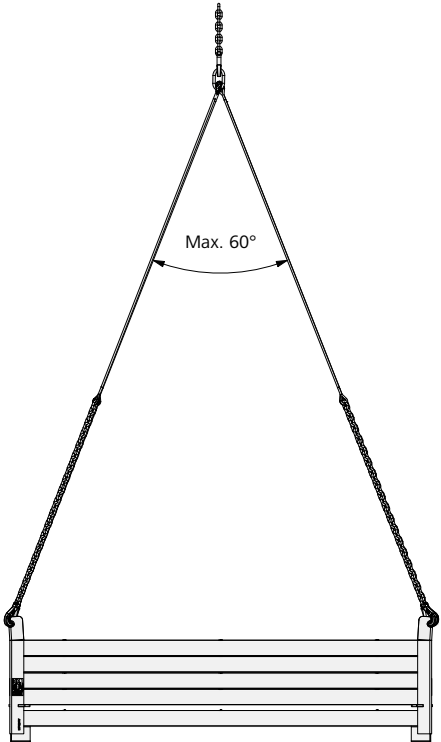


Fig. 82.4

Description	Ref. No.
Stacking angle 60/40/23.....	29-305-45

Single-sided formwork / climbing formwork

STB support frame for single-sided formwork (Fig. 83.1)

The Mammut XT formwork together with STB support frames can also be used when concrete has to be poured against earth, rock, an existing wall or the like, i.e. when a single-sided formwork is required.

STB 300 support frames allow for walls up to 3.30 m, while STB 450 support frames together with height extensions allow for wall heights of up to over 12 m.

Observe the Technical Instruction Manual for the support frame if required.

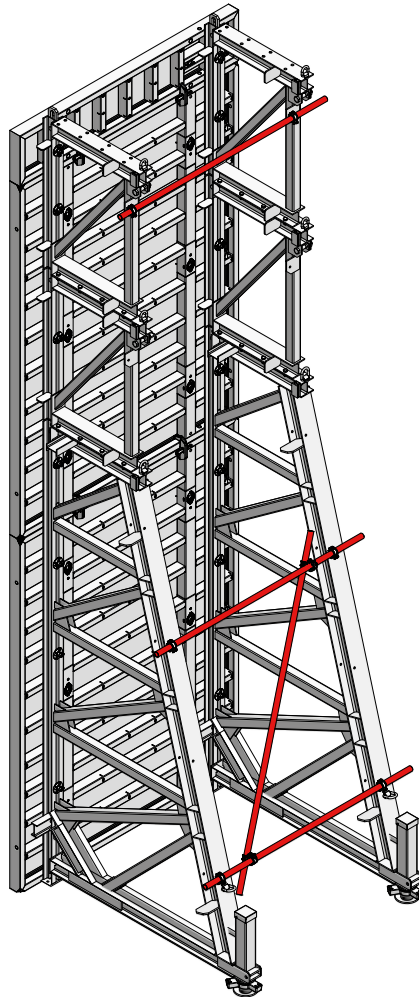


Fig. 83.1

KLK 230 climbing scaffold (Fig. 83.2)

When forming high walls, façades, pillars, staircase or elevator shafts, the Mammut formwork can be placed and secured on the KLK 230 climbing scaffold.

Observe the technical instruction manual for the KLK 230 climbing scaffolds if required.

Please note

The use of STB support frames and climbing scaffolds requires detailed formwork planning.

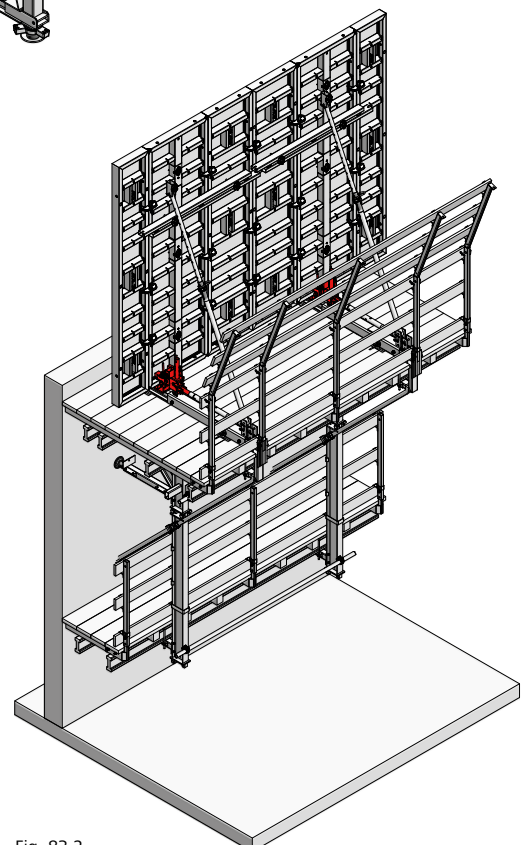


Fig. 83.2

Wall Formwork

Transport

Make sure that all material is secured properly.

Guidelines

Use one ratchet strap per metre of cargo. This means that 14 ratchet straps are required for a fully loaded truck with a trailer length of 13.60 m.

Depending on their size, the Mammut XT panels require two or three straps. Due to their low weight, Mammut XT corners require only two straps.

When moving panel stacks, make sure the panels are secure. MEVA secures the Mammut XT panels with anti-slip mats.

The transport safety devices should also be used when returning the material from building site.

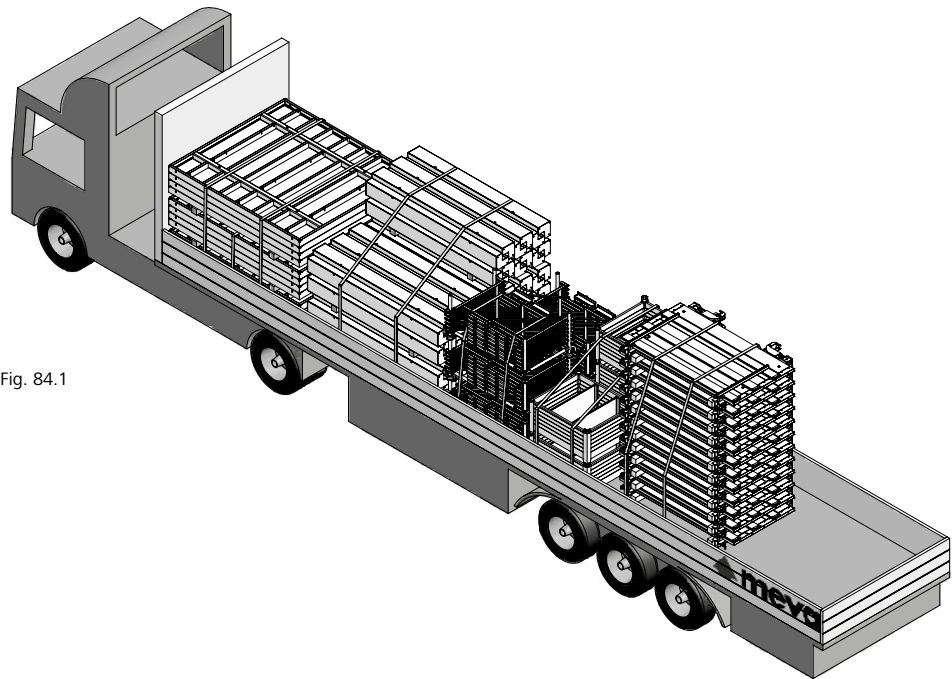


Fig. 84.1

Anti-slip mats per panel:

350 cm = 6 anti-slip mats per panel

300 cm = 6 anti-slip mats per panel

250 cm = 4 anti-slip mats per panel

125 cm = 4 anti-slip mats per panel

350/250 and 300/250 = 10 anti-slip mats per panel

Wall Formwork

Services

Cleaning

The formwork is cleaned professionally using industrial equipment upon return.

Reconditioning

Reconditioning is carried out as follows: The frames are checked and, if necessary, blasted, coated with a high-quality cured powder coating, and provided with a new facing. As long as the formwork equipment still has its full load capacity, correct dimensions and is fully functional, reconditioning will always be a more economical solution than purchasing new formwork. Please note that the cleaning and reconditioning service is not available in all countries in which MEVA does business.

Rentals

As we have a comprehensive range of equipment in stock, we offer our customers the option of renting supplementary material at peak times. The MEVA logistics centre guarantees rapid delivery throughout Europe. We also give prospective customers the chance to test MEVA formwork so they can see its benefits for themselves in actual use.

RentalPlus

For a flat-rate fee MEVA's "fully comprehensive insurance" for rental formwork and equipment covers all secondary costs that occur after return (excludes losses and write-offs). For the customer this means: Costing certainty instead of additional charges, an earlier end of the rental period and thus lower rental costs because you save the time required for cleaning and repairs.

Formwork drawings

Our application engineers worldwide work with CAD systems. This ensures that you always receive optimum formwork solutions and practice-oriented formwork and work cycle plans.

Special solutions

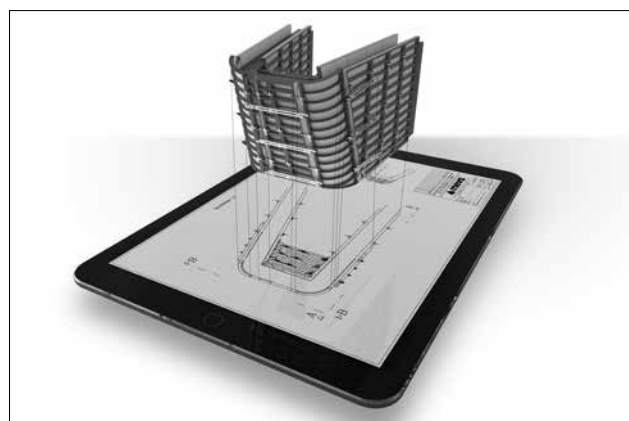
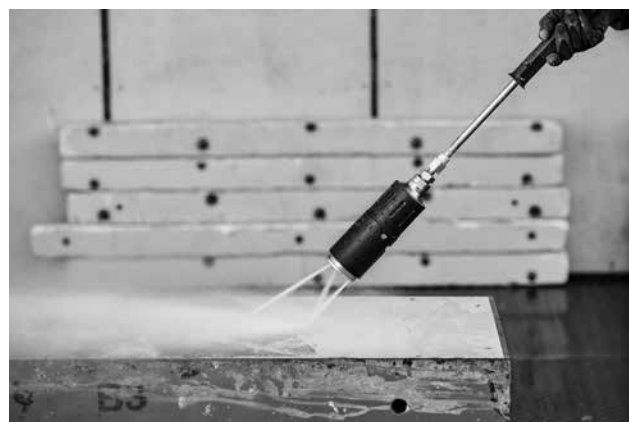
We can help with special parts, custom-designed for your project, to supplement our standard formwork systems.

Structural calculations

Generally, this is only necessary for applications such as single-sided formwork where the anchor parts are embedded in the foundation or the base slab. On request, we can perform structural calculations for such applications at an additional charge.

Formwork seminars

To ensure that all our products are used properly and efficiently, we offer formwork seminars. They provide our customers with a good opportunity to keep themselves up to date and to benefit from the know-how of our engineers.



Notes

A large grid of small dots for taking notes.